

www.tt-bahn.com

TILLIG **TT** BAHN



TILLIG **TT** BAHN

TT-Katalog 2015/2016

TT-Katalog

2015/2016

Dear model railway enthusiasts,

There are more than 500 different rolling stock items (not including track material, accessories etc.) in the new TT Catalogue 2015/2016. Now TILLIG Modellbahnen GmbH offers you a comprehensive range covering all epochs by means of which you can put together your own fleet for your home railway set. The new products for 2015 as well as the new additions for the autumn of 2015 which were published by the end of January or the end of August are already included in this catalogue.

However, to ensure that this range can be seen as clearly as possible, products will be removed from it every year. However, they have not been "lost for all time". New issues of these products may certainly be introduced again after a certain waiting period and shall be announced again in that case.

Here are a few special new products which will enrich the TT range in 2015:

New model transformations of the steam locomotive BR 95, and the locomotives of the BR 156/252 which extend the electrical locomotive range in a first step as the DR variant 252 and as the MEG version 156 are new in the range and will arrive in the retail outlets in the course of 2016.

We offer you a few complete redevelopments in the TT range for the goods wagons. The gas tank wagons, with or without a sunshield, are ideal as block trains, as long

or short versions, and also as new self-unloading cars of the OOt design. Here we can offer you interesting single wagons or also sets which can additionally be used in an almost unlimited number for smaller sets.

But also the many small things that are necessary to realistically design a model railway set have not been forgotten.

In addition to the new variants of the Robur lorry, now also with box bodies or as a flatbed / top cover version, the „well known“ H3A lorry will be subjected to an overhaul. A lot of new models await you meaning the range of cars and lorries now cover some three pages of this TT catalogue.

Additional new details, such as the interior lighting for the railway carriages should not be absent in a lot of model railway sets. In addition there is an assembly set for the lighting of the humped dining car and a train rear lighting for the railway carriage type Y/B 70.

Dear TT friends, we wish you a lot of fun with the new catalogue and we would be delighted if we can also continue to support you as TT model railway enthusiasts in the future. ■

Your TILLIG Model Railway team



Liebe Modellbahnfreunde,

über 500 unterschiedliche Artikel des Rollenden Materials sind – neben Gleismaterial und Zubehör – in dem neuen TT-Katalog 2015/2016 vertreten. Mittlerweile bietet TILLIG Modellbahnen GmbH in allen Epochen ein umfangreiches Sortiment an, aus dem Sie Ihren eigenen Fuhrpark für die heimische Anlage zusammenstellen können. Die Neuheiten 2015 als auch die Herbstneuheiten 2015, die per Ende Januar bzw. per Ende August veröffentlicht wurden, sind bereits in diesem Katalog enthalten.

Um dieses Sortiment dennoch übersichtlich zu gestalten, werden jedes Jahr Artikel entfallen. Diese sind allerdings nicht für „alle Zeiten verloren“. Neuauflagen dieser Artikel sind nach einer gewissen Wartezeit durchaus wieder möglich und werden dann neu angekündigt.

Hier noch einige besondere Neuheiten, die in 2015 das TT-Sortiment bereichern:

Neue Modellumsetzungen der Dampflokomotive BR 95 sowie der Lokomotiven der BR 156/252, die in einem ersten Schritt als DR-Variante 252 und als MEG-Version 156 den Bereich der Elektrolokomotiven ausbauen, sind neu im Angebot und werden im Laufe des Jahres 2016 in den Fachhandel kommen.

Einige komplette Neuentwicklungen im TT-Sortiment bieten wir Ihnen bei den Güterwagen an. Ideal für

Ganzzüge geeignet sind die Gaskesselwagen, mit oder ohne Sonnenschutzdach, als lange oder kurze Version sowie neue Selbstladewagen der Bauart OOt. Hier können wir Ihnen interessante Einzelwagen oder auch Sets anbieten, die auch für kleinere Anlagen nahezu uneingeschränkt einsetzbar sind.

Doch auch die vielen kleinen Dinge, die zur realistischen Gestaltung einer Modellbahnanlage notwendig sind, werden nicht vergessen.

Neben neuen Varianten des LKW Robur, jetzt auch mit Kofferaufbau oder als Pritsche/Plane-Version, wird auch der „altbekannte“ LKW H3A einer Überarbeitung unterzogen. Viele neue Modelle warten auf Sie, so dass sich das Angebot an PKW und LKW bereits auf drei Seiten in diesem TT-Katalog abbildet.

Zusätzliche neue Details, wie z. B. Innenbeleuchtungen für Reisezugwagen, dürfen auf vielen Modellbahnanlagen nicht fehlen. Dazu gibt es in diesem Jahr einen Bausatz zur Beleuchtung der „Buckelspeisewagen“ sowie eine Zugschlussbeleuchtung für die Reisezugwagen des Typs Y/B 70.

Verehrte TT-Freunde, wir wünschen Ihnen viel Spaß mit dem neuen Katalog und freuen uns, Sie auch weiterhin als TT-Modellbahner begeistern zu dürfen. ■

Ihr Team von TILLIG-Modellbahnen





4	Allgemeine Informationen/General informations
16	Länderbahnen der Epoche I State Railways of the German Empire (period I)
18	Deutsche Reichsbahn Gesellschaft Epoche II State Railways of the DRG (period II)
25	Deutsche Reichsbahn/German State Railway • Epoche III – Seite (page) 25 • Epoche IV/V – Seite (page) 38 •
60	Deutsche Bundesbahn/German Federal Railways • Epoche III – Seite (page) 60 • Epoche IV – Seite (page) 74 •
86	Deutsche Bahn AG/German Railway • Epoche V/VI – Seite (page) 86 •
110	Privatbahnen Deutschland Epoche V/VI Private Railways in Germany period V/VI
121	Ausländische Bahnverwaltungen/Foreign Railways
173	START-Programm/Models for Beginners
176	Einsteiger-Sets/Beginner sets Straßenfahrzeuge/Vehicles
186	Digital/Digital
194	Bettungsgleissystem/Bedding track system
201	Modellgleissystem/Advanced track system
216	STYROSTONE®-Gleisbettung/ STYROSTONE® -Track bedding
222	Zubehör & Ersatzteile/Accessories & spare parts
231	TILLIG-Straßenbahn-Gleissystem/TILLIG-Tram track system
232	Händlerverzeichnis Ausland List of importeurs and dealers in foreign country
233	Index und Impressum

Bahngesellschaften / Railway companies

BadStB	Großherzoglich Badische Staatseisenbahnen
K.Bay.Sts.B.	Königlich Bayerische Staatseisenbahnen
K.P.E.V.	Königlich Preußische Eisenbahn-Verwaltung
K.Sächs.Sts.E.B.	Königlich Sächsische Staatseisenbahnen
BC	Weißrussische Staatseisenbahn
BDZ	Bulgarische Staatseisenbahn
ČD	Tschechische Staatsbahn (ab 1992)
ČD Cargo	ČD Cargo
CFL	Luxemburgische Staatsbahn
CFR	Rumänische Eisenbahngesellschaft
ČSD	Tschechoslowakische Staatsbahn (bis 1992)
DB	Deutsche Bundesbahn (1949-1993)
DB AutoZug	DB AutoZug
DB NachtZug	DB NachtZug
DB AG	Deutsche Bahn Aktiengesellschaft (ab 1994)
Deutsche Bundespost	Deutsche Bundespost
DR	Deutsche Reichsbahn (1945-1993)
DRG	Deutsche Reichsbahn Gesellschaft (1920-1945)
DSB	Dänische Staatsbahnen
FS	Italienische Eisenbahngesellschaft
JZ	Jugoslawische Eisenbahnen

LG	Litauische Staatsbahn
MAV	Ungarische Staatsbahnen
NS	Niederländische Staatsbahnen
ÖBB	Österreichische Bundesbahnen
OSE	Griechische Eisenbahnen
PKP	Polnische Staatsbahn
PKP Cargo	PKP Cargo
PKP INTERCITY	PKP INTERCITY
PKP Przewozy Regionalne	PKP Przewozy Regionalne
RENFE	Spanische Eisenbahnen
RZD	Russische Eisenbahnen (ab 1992)
SBB/CFF/FFS	Schweizerische Bundesbahnen
SBB Cargo	SBB Cargo
SJ	Schwedische Staatsbahnen
SNCB	Belgische Eisenbahngesellschaft
SNCF	Französische Eisenbahngesellschaft
SZD	Eisenbahnen der UdSSR (bis 1992)
VR	Finnische Staatsbahn
ŽSR/ZSSK	Slowakische Staatsbahn
ZSSK Cargo	ZSSK Cargo

Private Bahngesellschaften / privat railway companies























AAE	Ahaus Alstätter Eisenbahn GmbH
ARRIVA	ARRIVA
AWT	Advanced World Transport
BE	Bentheimer Eisenbahn AG
BLS/BLS Cargo	BLS Lötschbergbahn
EGP	Eisenbahngesellschaft Potsdam mbH
ermewa	Groupe Ermewa SA
EVB	Eisenbahnen und Verkehrsbetriebe Elbe-Weser
GATX	General American Transportation Corporation
GYSEV	Gyor-Sopron-Ebenfurti Eisenbahn
HGK	Häfen und Güterverkehr Köln AG
hvl	Havelländische Eisenbahn
IGT	Inbetriebnahmegesellschaft Transporttechnik mbH
ITL	ITL Eisenbahngesellschaft mbH
KEG	Karsdorfer Eisenbahngesellschaft GmbH
LOKOMOTION	Lokomotion Gesellschaft für Schienentraction mbH
LOTOS Kolej	LOTOS Kolej
LTE	LTE Logistik- und Transport-GmbH
MEG	Mitteldeutsche Eisenbahn GmbH
metronom	Metronom Eisenbahngesellschaft mbH
MRCE	Mitsui Rail Capital Europe GmbH
NACCO	NACCO
NBE RAIL	NBE RAIL GmbH
NORDCARGO	NORDCARGO
OHE	Osthannoversche Eisenbahnen AG
On Rail GmbH	On Rail GmbH
PRESS	Pressnitztalbahn
Railion NL	Railion Niederlande
RAILPOOL	Railpool Holding GmbH & Co. KG
RheinCargo	RheinCargo GmbH & Co. KG
RYKO PLUS s.r.o.	RYKO PLUS GmbH
SGL	Schiene-Güter-Logistik GmbH
SETG	Salzburger Eisenbahn- und Tramway-Gesellschaft
SUAS	Sokolovska Uhelna a.s.
Städtebahn Sachsen	Städtebahn Sachsen
Steiermarkbahn	Steiermarkbahn Transport und Logistik GmbH
Viamont a.s.	Viamont a.s.
VTG	VTG Aktiengesellschaft
WLC	Wiener Lokalbahnen Cargo GmbH



Hier finden Sie eine Übersicht der Bahnverwaltungen/-gesellschaften (beginnend mit der Länderbahn, staatlicher Bahngesellschaften, privater Bahngesellschaften in alphabetischer Reihenfolge).

Diese Übersicht hat keine Gewähr auf Vollständigkeit.

Technische Daten und Epochen/Technical informations and epoch

- | | |
|--|--|
|  Epochenbezeichnung (NEM 806 D)
Epoch (NEM 806 D) |  Oberleitungsbetrieb möglich
Switchable to use catenary |
|  Länge über Puffer in mm
Length from buffer to buffer |  Befahrbarer Mindestradius
Minimum radius |
|  2-Licht-Spitzensignal mit Fahrrichtung wechselnd
2-front-light, dependet on the direction of traffic |  Kupplungsaufnahme und Kurzkupplungskinematik (NEM 358) / Coupling pick-up and close coupling kinematics (NEM 358) |
|  2-Licht-Spitzensignal /2 Schlussleuchten, fahrtrichtungsabhängig
2-front-light/2 rear light, dependet on the direction of traffic |  Kupplungsaufnahme (NEM 358) ohne Kurzkupplungskinematik / Coupling pick-up (NEM 358) without close coupling kinematics |
|  3-Licht-Spitzensignal /2 Schlussleuchten, fahrtrichtungsabhängig
3-front-light/2 rear light, dependet on the direction of traffic |  Hauseigene Kupplungsaufnahme
Own Coupling pick-up |
|  3-Licht-Spitzensignal an beiden Fahrzeugenden, fahrtrichtungsabhängig / 3-front-light on both sides of the car, dependet on the direction of traffic |  Elektrische Schnittstelle (NEM 651), mit Steckvorrichtung / Electrical interface (NEM 651), with plug |
|  3-Licht-Spitzensignal vorn/2-Licht-Spitzensignal hinten, fahrtrichtungsabhängig / 3-front-light on the frontside/2-front-light on the backside, dependet on the direction of traffic |  Elektrische Schnittstelle (NEM 651), ohne Steckvorrichtung / Electrical interface (NEM 651), without plug |
|  Mit Inneneinrichtung ausgestattet
Equipped with interior decoration |  12-polige Digitalschnittstelle PluX12 (NEM 658)
12 pole digital interface PluX12 (NEM 658) |
|  Mit Innenbeleuchtung ausgestattet
Equipped with interior lighting |  18-polige Digitalschnittstelle Next18 (NEM 662)
18 pole digital interface Next18 (NEM 662) |
|  Innenbeleuchtung nachrüstbar
Interior lighting possible to refit |  Im Interzonenzugverkehr (BRD – DDR) eingesetzte Reisezugwagen
Railway carriages used in interzone transport (West Germany – German Democratic Republic) |
|  Bei Digitalbetrieb Glühlampen auf mind. 10V wechseln (Art. 08879)/Replace all bulbs with at least 10V-type bulbs before using these model cars on a digital run layout (product no. 08879) |  International verkehrende Reisezugwagen
Railway carriages that operate internationally |

Epoche I Länderbahn-Epoche	Epoche II Reichsbahn-Epoche	Epoche III Frühe Bundesbahn (D)- und Reichsbahn (DDR)-Epoche
Von 1835 bis zur Gründung der Deutschen Reichsbahn (1920) From 1835 till the foundation of the German State Railway (1920)	Von Gründung der Deutschen Reichsbahn bis Ende des II. Weltkrieges (1920 – 1945) From the foundation of the German State Railway till the end of the 2nd World War (1920 – 1945)	Vom Ende des II. Weltkrieges bis etwa 1970 From the end of the 2nd World War till 1970
Epoche IV Späte Bundesbahn (D)- und Reichsbahn (DDR)-Epoche	Epoche V Epoche der Deutschen Bahn AG	Epoche VI Epoche des liberalisierten Schienenverkehrs
Etwa ab 1968/70 bis 1990 About 1968/70 till 1990	Fahrzeuge in Farbgebung ab 1990 – 2007 Railways in colouring of 1990 till 2007	Ab 2007 Since 2007

A = Auslaufmodell/Model is discontinued

Technische Änderungen an Modellen, sowie die Vergabe neuer Betriebsnummern und geänderte Lieferbedingungen sind vorbehalten. Alle Angaben erfolgen ohne Gewähr. /All rights reserved. Subject to modification and altered availability without prior notice. All specifications, dimensions and illustrations subject to change.

TT: Die ideale Nenngröße mit Tradition / TT - The ideal gauge with tradition

Die Nenngröße TT blickt mittlerweile auf eine 70jährige Tradition zurück. 1946 entstanden von „H. P. Products“ in den USA die ersten Modelle im Maßstab 1:120. Kurze Zeit später begann „Rokal“ auf dem (west)deutschen Markt mit seiner TT-Produktion. Einen maßgeblichen Beitrag zur TT-Entwicklung leistete schließlich die (Ost)Berliner Firma „Zeuke & Wegwerth KG“ (ab 1972 „VEB Berliner TT Bahnen“ – BTTB), die 1957 mit der Etablierung und dem rasanten Ausbau eines neuen TT-Sortimentes begann. Mit der Übernahme von BTTB im Jahre 1993 und der Verlagerung der TT-Produktion nach Sebnitz war es für TILLIG zweifelsohne eine spannende Herausforderung, an die erfolgreiche Entwicklung der Berliner Traditionsfirma anzuknüpfen. Zunächst mit zahlreichen Überarbeitungen, kurze Zeit später bereits mit kompletten Neuentwicklungen. Und das Ergebnis – dies kann sich sehen lassen: Etwa 50 unterschiedlichste Triebfahrzeug-Baureihen und beinahe doppelt so viele Wagen-Typen sind in über 20 Jahren entstanden. Und die Modell-Vielfalt wächst von Jahr zu Jahr weiter...

The TT gauge can now look back on a 70 year tradition. The first models with a scale of 1:120 were created by "H.P. Products" in the United States in 1946. A short time later "Rokal" commenced its TT production in the West German market. Ultimately the (East) Berlin company "Zeuke & Wegwerth KG" (trading under the name of "VEB Berliner TT Bahnen" – BTTB from 1972 onwards) made a substantial contribution towards TT development which commenced in 1957 with the establishment and the rapid extension of a new TT range. Upon the takeover of BTTB in 1993 and the transfer of production activities to Sebnitz it was unquestionably an exciting challenge for TILLIG to build on the successful development of the Berlin-based company with a rich tradition. Initially with numerous redesigns, and shortly afterwards with entirely new developments. And the results have been very impressive: Some 50 of the most diverse traction unit series and almost double that number of carriage types have been produced in a period spanning more than 20 years. And the range of models continues to grow from year to year...

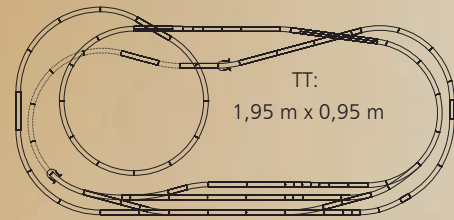

Größenvergleich zwischen H0 und TT

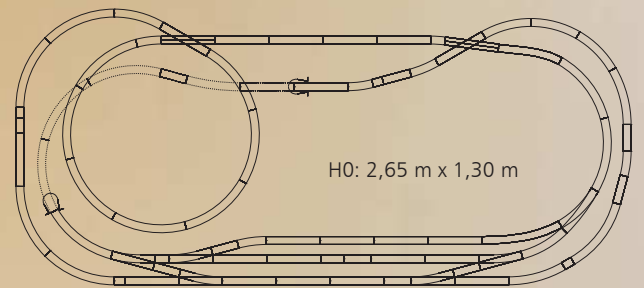

„Optimale Kombination von minimalem Raumbedarf, maximaler Modelltreue und Funktionssicherheit ...“

Werner Zeuke,
Firmen-Gründer von Zeuke & Wegwerth

- Nur ca. 60% des Platzbedarfes gegenüber H0
- Detaillierung und Fahrverhalten ohne Einschränkung mit H0-Großserienmodellen vergleichbar
- Idealer Verkleinerungsmaßstab mit geringeren platzbedingten Kompromissen als in H0
- Gegenüber der Nenngröße N wiederum sind kleine Details (auch im Anlagenbau) bedeutend besser umsetzbar.

„Ideal combination of minimum space requirements, maximum faithfulness of the model to the prototype and functional reliability...“

Werner Zeuke,
Company's founder of Zeuke & Wegwerth

- A TT scale model railway only requires approx. 60% of the space of a comparable H0 set-up.
- Still offers models that can be handled easily and are realistic, which certainly compare well to H0 large series models without limitations in terms of their levels of detail and driving behaviour.
- Due to the ideal 1:120 scale far fewer space-related compromises are called for compared to the H0 scale.
- On the other hand small details even in the construction of the set itself can be realised much more favourably than in the case of the N nominal scale.

Die Goldene Mitte

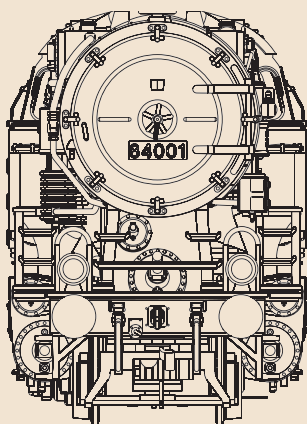

Nenngröße H0
Maßstab 1:87
Spurweite 16,5 mm

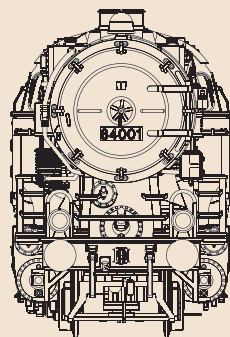

Nenngröße TT
Maßstab 1:120
Spurweite 12 mm

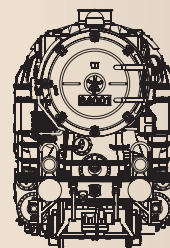

Nenngröße N
Maßstab 1:160
Spurweite 9 mm

Qualität und Präzision in allen Bereichen ...

Präzision, Detailgenauigkeit und Zuverlässigkeit: Dies zeichnet unsere TILLIG-Produkte aus. Um dieses Ziel zu erreichen, stellen wir uns selbst natürlich höchste Ansprüche in all unseren Fertigungsschritten.

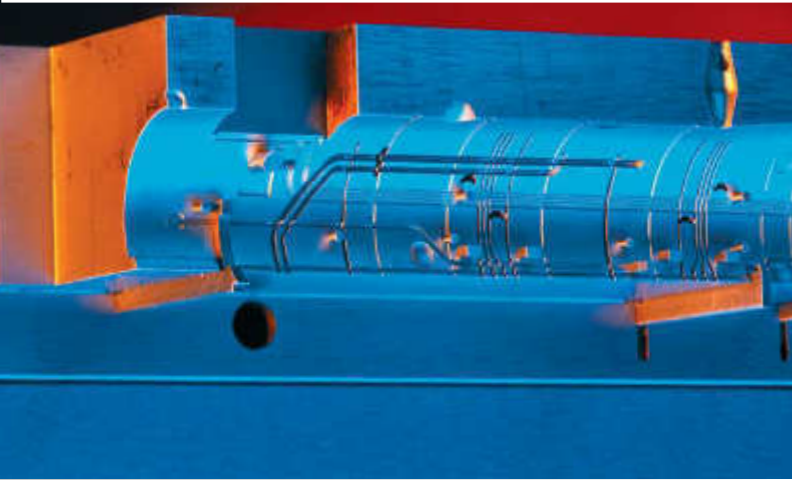
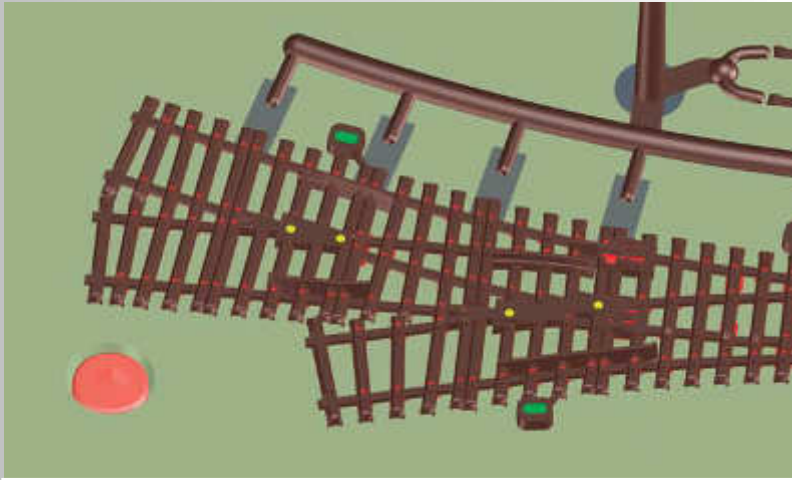

Konstruktion:

Jahrelange Erfahrung unserer Konstrukteure, moderne CAD-Systeme und die ständige Suche nach Innovationen: hier wird der „Grundstein“ für ein erfolgreiches TILLIG-Modell gelegt. In der Konstruktion entstehen alle TILLIG-Modelle.

Design:

Many years of experience of our designers, modern CAD systems and a constant search for innovations: The „foundation stone“ for a successful TILLIG model is laid here. All TILLIG models emerge in the construction.

Werkzeugbau:

Hohe Detailtreue, feinste Gravuren an den Modellen, Toleranzen im Hundertstel-Millimeter-Bereich ... Dafür steht unseren Spezialisten im Werkzeugbau modernste Technik zur Verfügung.

Tool construction:

High attention to detail, the finest engravings on the models, tolerances down to a hundredth of millimetre ... State of the art technology is available to our specialists in the tool construction sector to this end.

Kunststoffspritzerei:

Automatische Spritzgießmaschinen gewährleisten einen hochproduktiven Ausstoß an Spritzteilen. Die optimale Einstellung und ständige Überwachung der Spritzparameter (Temperatur, Druck, Abkühlzeit usw.) ist unerlässlich für die hochwertige Qualität der Kunststoffteile.

Plastic injection moulding plant:

Automated injection moulding machines guarantee a highly productive output of injection moulded parts. The ideal settings and constant monitoring of the injection moulding parameters (temperature, pressure, the cooling period etc) is imperative to ensure the quality of the plastic parts.

Quality and precision in all regions ...

Precision, attention to detail and reliability. These are the outstanding features of our TILLIG-products. We do of course subject our work to the highest demands in all our manufacturing steps to achieve this goal.

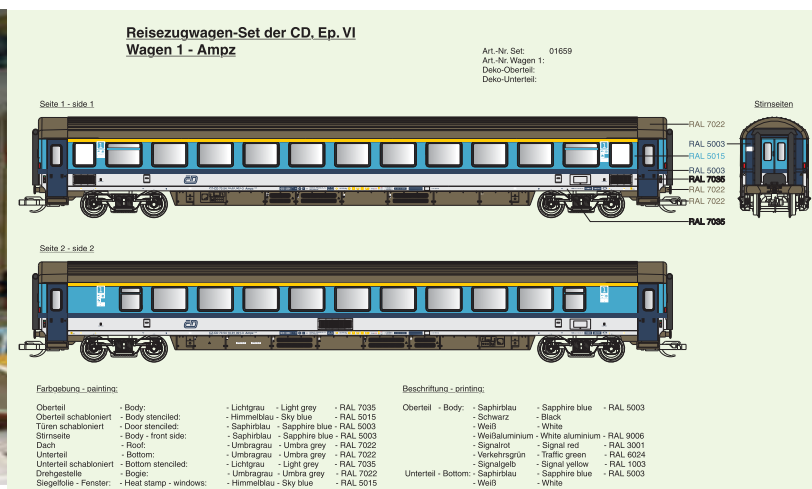
**Druckvorstufe:**

Nach genauerer Recherche der Dekoration des Originals erfolgt am PC die Erstellung der Vorlagen für Lackierung und Bedruckung.

Pre-press:

The templates for the lacquering and printing on the PC are produced following the most precise research of the decoration of the original.

Lackiererei und Druckerei:

Die Lackierung der Modelle erfolgt mit der Hand-Spritzpistole. Große Erfahrung für einen gleichmäßigen Farbauftrag ist hier Voraussetzung. Eine gestochen scharfe Bedruckung unserer Modelle wird durch das Tampondruck-Verfahren ermöglicht, oft sind kleinste Anschriften nur noch unter der Lupe lesbar.

Paintshop and printing shop:

The models are painted with a hand spray gun. Great experience is essential here to ensure the paint is applied evenly. High definition printing of our models is made possible by pad printing, often smallest inscriptions can only be read under a loupe.

Endmontage:

Sowohl der Gleisbau als auch die Montage von Modellen erfolgen fast ausschließlich in Handarbeit. Geduld und Fingerfertigkeit sind hier gefragt. Dies meistern unsere Mitarbeiter der Montage stets mit viel Liebe zum Detail.

Final assembly:

Both the construction of the structure and the assembly of the models is performed almost exclusively by hand. Patience and dexterity are called for here. Our assembly employees always master this with a great deal of painstaking attention to detail.

Herzlich willkommen bei TILLIG!

Sebnitz ist bekannt als Firmensitz des weltweit größten Herstellers der beliebten TT-Modellbahn: TILLIG Modellbahnen GmbH. Entdecken Sie hier in unserem Museum die über 100-jährige Geschichte der Modellbahn. Betrachten Sie dazu eine umfangreiche Anzahl von Dokumenten, Fotos, Schaustücken und Modellbahnanlagen. Weiterhin präsentieren wir Ihnen in unserem Museum zahlreiche Handmuster oder aktuelle Arbeitsstände aktueller Formneuheiten, die noch nicht im Handel verfügbar sind.

In der zweiten Etage bieten wir unseren Besuchern u.a. auch wechselnde Sonderausstellungen zu verschiedenen Themen. Seit der Neueröffnung im Mai 2011 konnten Sie bereits zusätzliche Ausstellungen zu folgenden Themen besuchen:

- „TT in Tschechien“ (November 2011 bis März 2013)
- „Die Geschichte von Auhagen“ (April 2013 bis März 2014)
- „Gleissortimente der Firma TILLIG“ (April 2014 bis Aug. 2015)
- „Schiff und Bahn“ (neu seit September 2015)

Unser Schulungs- und Seminarraum bietet Ihnen die Möglichkeit, an unterschiedlichsten Workshops rund um das Thema „Modellbahn“ teilzunehmen. Im Ladengeschäft unserer Galerie können Sie nach Herzenslust im aktuellen TILLIG-Sortiment stöbern. Und auch unser Kundendienst bietet Ihnen einen erstklassigen Service vor Ort.

Nicht zuletzt finden Sie bei uns auch attraktive Sondermodelle – exklusiv von Ihrer Modellbahn-Galerie. Ob Lokomotiven, Personen- und Güterwagen oder Automodelle: Ihre Galerie bietet Ihnen regelmäßig neue TT-Highlights für Ihre eigene Sammlung.

Sie sehen also: Es gibt viele Gründe, die für einen Besuch in unserer TILLIG-Modellbahn-Galerie sprechen. Informationen über Öffnungszeiten, Exklusivmodelle, aktuelle Ausstellungsthemen, Workshop-Termine und vieles mehr finden Sie im Internet unter www.tillig.com.

Liebe Modellbahnfreunde, wir freuen uns darauf, Sie bei uns in Sebnitz begrüßen zu dürfen!

Ausstellung
exhibition

Ladengeschäft
store

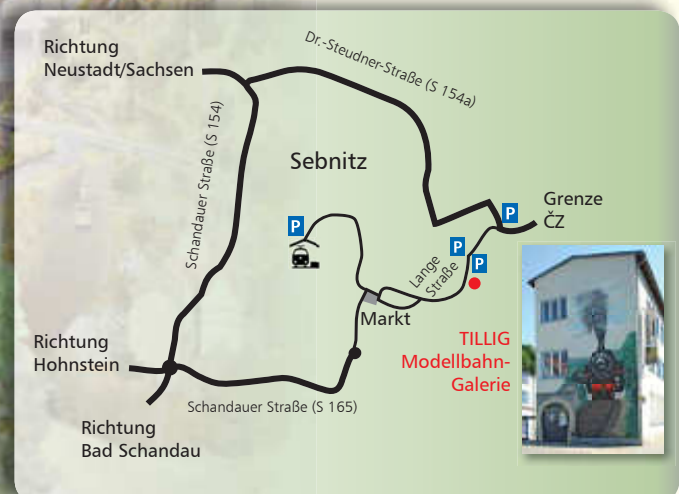

Welcome to TILLIG!

We kindly welcome you to our museum in the TILLIG Model Railroad Gallery. Sebnitz is the official headquarters of the world's most renowned manufacturer of the famous TT-model railroad: TILLIG Modellbahnen GmbH.

Our museum provides you deep insights into the 100-year old history of the model railroad. Discover our large collection of documents, pictures, show pieces, and model railroad systems. Besides, our museum holds a collection of numerous hand-made samples or the current progress of our latest designs and shapes, which haven't been launched, yet.

On the second floor, we organize special themed exhibitions for our visitors every once in a while. Since 2011, we have organized the following special themed exhibitions:

- "TT in Czechia" (2011 – 2013)
- "The history of Auhagen" (2013 – 2014)
- "Track assortments manufactured by TILLIG" (2014 – 2015)
- "Ship and railway" exhibition (since september 2015)

Our training and seminar rooms provide our visitors with the opportunity to participate in a variety of workshops dealing with the subject "Model railroad" (please visit www.tillig.com for more information). Our model railroad gallery invites you to discover our most recent TILLIG-TT-/H0- and narrow-gauge product range. Needless to say, that our competent customer support team is always at your service.

And not least you also find attractive special models – exclusively from your model railway gallery with us. Whether they are locomotives, passenger carriages and freight wagons or car models: Your gallery regularly offers new TT highlights for your own collection.

There are plenty of reasons to drop by for a visit at our TILLIG Model Railroad Gallery. More details and information about our current exhibition themes, as well as the opening hours of the TILLIG Railroad Gallery can be found online: www.tillig.com.

Come and join us, we look forward to your visit to Sebnitz!

Modellbahn-Galerie

- **Museum | Kundendienst | Verkauf**
- **Info und Beratung TILLIG-TT-Club**

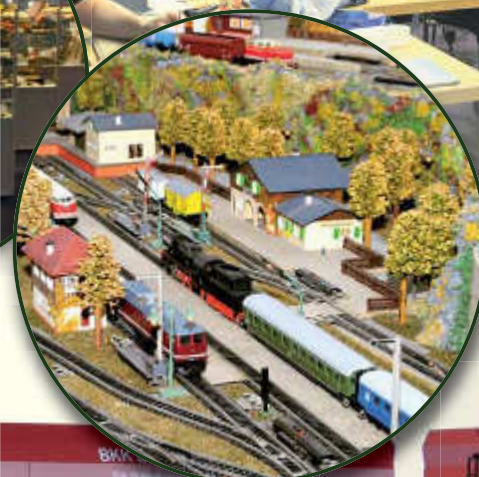

Workshops
workshops

Exklusive Galeriemodelle
exklusive items



TILLIG-TT-Club

... aus Überzeugung und Leidenschaft!

Im Jahr 1997 wurde der TILLIG-TT-Club gegründet. Nach nunmehr 18 Jahren des Bestehens haben sich über 4.300 TT-Kunden aus dem In- und Ausland im TT-Club angemeldet. Und die Anzahl der Club-Mitglieder steigt weiter. Hier erwarten Sie eine Vielzahl von Anregungen, Tipps und Tricks, aktuelle Informationen rund um das TT-Hobby und direkt aus dem Werk der TILLIG-Modellbahnen. Im Laufe eines Jahres erhalten Sie direkt an Ihre Adresse insgesamt vier Aussendungen zugeschickt. Diese enthalten die jeweils aktuellen Ausgaben unseres Club-Magazines „Club aktuell“, alle neu erschienenen Prospekte, Gutscheine für den Jahreskatalog TT usw. Doch auch der persönliche Kontakt ist uns sehr wichtig. So veranstalten wir jährlich unser Club-Treffen. Hier können Sie mit unseren Mitarbeitern fachsimpeln, Anregungen und Kritik anbringen oder einfach nur das Zusammensein mit TT-Bahnern genießen.

Der Club der idealen Spur

Viele interessierte Besucher kamen auch 2015 wieder zum Tag der offenen Tür mit TILLIG-TT-Club-Treffen nach Sebnitz. Rechts ein Ausschnitt aus dem „Club aktuell“ mit einem Rückblick auf dieses Event.

Hier noch einmal unsere Club-Leistungen:

- Jährlich vier Ausgaben des Club-Magazines „Club aktuell“ (Umfang jeweils 48 Seiten)
- Gutschein für einen kostenlosen TT-Jahreskatalog
- Persönliche Clubkarte
- Zusätzliche Publikationen und Prospekte
- Aktuelle Club-Newsletter an Ihre persönliche E-Mail-Adresse
- Kostenloser Eintritt in die Modellbahn-Galerie mit Museum (siehe Seite 10)
- Ermäßigte Eintritte auf ausgewählte Messen
- Jährliches Club-Treffen mit Möglichkeit zur Teilnahme an einem Workshop, 2016 mit Montage einer exklusiven Dampflokomotive BR 56 mit Rangiertritt, DR, Ep. III (siehe Abb. links unten)
- Exklusive Club-Modelle (Einige Beispiele für Modelle des Jahres 2016 finden Sie auf den Seiten 13/14)
- Exklusiver Mitgliederbereich auf der TILLIG-Homepage
- Preisnachlass bei Ersatzteilen
- Persönliche Betreuung für alle Fragen rund um das TT-Hobby über unsere Club- und Kundendienst-Hotline
- Kostenloser Jahreswagen, 2016 mit einer Formneuheit!

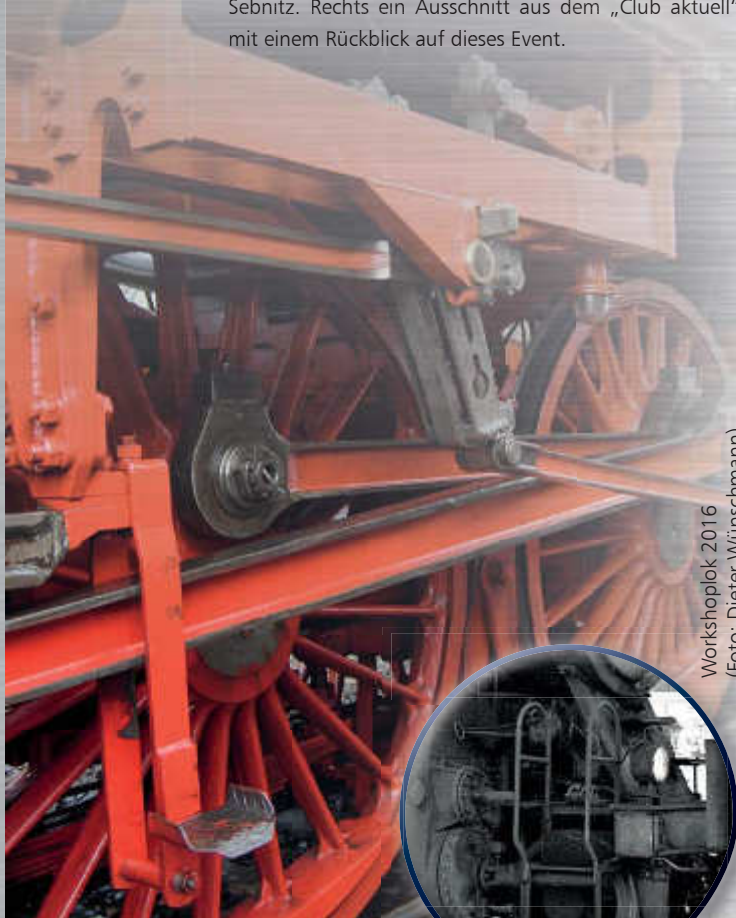

Workshoplok 2016
(Foto: Dieter Wünschmann)



Exklusiv für Club-Mitglieder
exclusive for TT Club members

501702

Ellok BR 212 001-2, Designstudie mit DR-Beschriftung, Epoche IV

Electric locomotive BR 212 001-2, design conception in DR livery, ep. IV

Mit unseren Club-Magazinen erhalten Sie viel Wissenswertes zum Thema Modellbahn, im Besonderen alles rund um die Spurweite TT wie z. B.: / You discover a lot of things worth knowing on the theme of the model railways with our club magazines, in particular everything about the TT track gauge such as:

- Neuheitenvorstellungen
- Interna aus dem TT-Werk
- Informationen zu Veranstaltungen und Ausflugstipps
- Extra Berichte über Sonder- und Exklusivmodelle
- Wissenswertes zur TT-Geschichte
- Vorbild- und Modellvorstellungen
- Technik bei der Modellbahn
- Anlagen- und Modulbau
- Landschaftsbau neben dem Gleis
- Zugbildungen
- Aktuelle Informationen, wie z. B. Liefertermine.

- Presentation of novel features
- Internal information from the TT plant
- Information on events and excursion tips
- Extra reports on special and exclusive models
- History of TT
- Presentations of prototypes and models
- Model railway technology
- Set and module construction
- Landscape construction next to the track
- Train formations
- Current information such as delivery dates.



Exklusiv für Club-Mitglieder
exclusive for TT Club members

501698

**Niederbordwagen,
beladen mit Old-
timer-Traktor, DRG,
Epoche II**

Low side car with tractor,
DRG, ep. II

Wir freuen uns, wenn auch Sie sich für eine Mitgliedschaft im TILLIG-TT-Club entscheiden und sich gleich anmelden. Ihre Anmeldeunterlagen können Sie bequem von zu Hause auf unserer Homepage www.tillig.com anfordern. We would be delighted if you would also decide to become a member of the TILLIG-TT club and would register immediately. Either in writing using our registration brochure or directly on our homepage www.tillig.com.

Exklusiv für Club-Mitglieder:
Alle Club-Modelle aus den letzten Jahren können, so lange der Vorrat reicht, noch über den TILLIG-TT-Club bestellt werden.

*Exclusive for members of TTClub:
All club models of the last few years can be ordered at TILLIG-TT-Club as long as the stocks last.*

TILLIG-TT-Club:
Promenade 1, 01855 Sebnitz
Fax: 035971/903-19
E-Mail: tt-club@tillig.com

Club-Hotline-Tel.: 035971/53516
(Dienstag 15.00 – 18.00 Uhr)

Kundendienst-Tel.: 035971/903-45
(Di. 13 – 18 Uhr, Do. 11 – 16 Uhr)

Exklusiv für Club-Mitglieder
exclusive for TT Club members

501700 - FORMNEUHEIT / NEW
Jahresmodell 2016

Offener Güterwagen Eaos, Captrain, Ep. VI

Modell of the year 2016

Open car Eaos,
Captrain, ep. VI



Hinweis:
Das Modell erhält andere Drehgestelle (Bauart Minden),
die in dieser Konstruktionszeichnung noch nicht dargestellt sind.

TILLIG-TT-Club

The TILLIG-TT-club was founded in 1997. Now that it has existed for 18 years more than 4.300 TT customers have joined the TT club in Germany and abroad. A large number of suggestions, tips and tricks, current information about all aspects of the TT hobby and directly from the TILLIG model railway factory await you here. You will have a total of four packages sent to your address in the course of a year. They contain the respective current editions of our club magazin „Club aktuell“, all the brochures that have just been published, gift vouchers for the annual catalogue TT etc. But personal contact is also very important for us. That is why we organise our club meetings annually. Here you can talk shop with our employees, bring up suggestions and criticisms or simply just enjoy spending time with TT model railway enthusiasts.



Here is an overview of our club services once again:

- Four editions of the club magazin „Club aktuell“ respectively per year
- Free TT annual catalogue
- Personal club card
- Additional publications and brochures
- Current club newsletter to your personal e-mail address
- Free entrance to the model railway gallery with the museum (see page 10)
- Annual club meeting with option of participating in a workshop
- Exclusive club models at special terms and conditions
- Spare parts at discount prices
- Personal support for questions relating to your TT-Hobby via our club and customer service hotline
- Free TT club annual car.

501696

Güterwagenset „Eisenwerke West“, DR, Ep. III

Freight car set „Eisenwerke West“,
DR, ep. III



Exklusiv für Club-Mitglieder
exclusive for TT Club members

**FORM-
NEUHEIT!**

Messen

Besuchen Sie uns auf einer der unten aufgeführten Messen. Dort stehen wir Ihnen gern für alle Fragen rund um unser TT-/H0-/Schmalspur- und Straßenbahngleis-Gesamtsortiment zur Verfügung. Natürlich können Sie sich auch über den TT-Club informieren.

TILLIG Modellbahnen will be represented at the following trade fairs. You can also inform yourself about our TT-/H0-/Narrow gauge and tram track products and the TT-Club there.

**MODELL
HOBBY**

**modell
hobby
Spiel**

**MODELLBAU
MESSE**

HOBBY

**Faszination
Modellbau**



02. Okt. – 04. Okt. 2015	„Modell – Hobby – Spiel“ Leipzig
08. Okt. – 11. Okt. 2015	„Modell Hobby“ Prag/Tschechien
17. Okt. – 18. Okt. 2015	„Hobby“ Poznan/Polen
23. Okt. – 26. Okt. 2015	„Modellbaumesse“ Wien/Österreich
30. Okt. – 01. Nov. 2015	„Faszination Modellbau“ Friedrichshafen
12. Feb. – 14. Feb. 2016	„10. Erlebnis Modellbahn“ Dresden
04. März – 06. März 2016	„Faszination Modellbahn“ Sinsheim
20. April – 24. April 2016	„Intermodellbau“ Dortmund
04. Juni 2016	„Tag der offenen Tür“ bei TILLIG Modellbahnen in Sebnitz



Dampflokomotive P8 der K.P.E.V.
Steam locomotive class P8 of the K.P.E.V.

- Neue Loklaternen mit warm-weißer LED / new lamps with warm-white LED
- Kurzkupplungskinematik am Tender / close coupling kinematic at the tender
- Ursprungsausführung in Grün, ohne Windleitbleche und mit Gasbeleuchtung, ohne drittem Spitzenlicht / original version in green, without smoke deflectors and with gas lighting, without 3rd headlight
- Tenderbauart 2'2'T 21,5 / tender type 2'2'T 21,5

	155			Rmin			
				310			
Art.-Nr: 02022		UVP in €: 289,90					



Dampflokomotive G 8.2 der K.P.E.V.
Steam locomotive class G 8.2 of the K.P.E.V.

	147						
Art.-Nr: 02165		UVP in €: 221,50					



Reisezugwagenset der K.P.E.V., bestehend aus drei Abteilwagen
Passenger coach set of the K.P.E.V., with three different passenger coaches

	334						
Art.-Nr: 01682		UVP in €: 99,50					



Abteilwagen der K.P.E.V.
Passenger coach of the K.P.E.V.

	110						
Art.-Nr: 13149		UVP in €: 34,50					



Packwagen (Pw3 pr-11) der K.P.E.V.
Baggage wagon (type Pw3 pr-11) of the K.P.E.V.

		110			
	NEM			NEM	
Art.-Nr.: 13455	UVP in €: 28,90				



Güterwagenset der K.P.E.V. / der Eisenbahnen in Elsass-Lothringen, bestehend aus zwei offenen Güterwagen Ommk(u)
Freight car set of the K.P.E.V. / Railways in Elsass-Lothringen with two open car Ommk(u)

Handmuster

NEU		161			
	NEM			NEM	
Art.-Nr.: 01719	UVP in €: 39,90				

- Auslieferung mit Speichenradsätzen / delivery with spoked wheels sets



Rungenwagen Rm der K.P.E.V.
Stake car Rm of the K.P.E.V.

		96			
	NEM			NEM	
Art.-Nr.: 14628	UVP in €: 18,50				



Kalkkübelwagen „Bayrische Stickstoffwerke A.G.“, eingestellt bei der K.P.E.V.
Car for transport of limestone „Bayrische Stickstoffwerke A.G.“ of the K.P.E.V.

NEU		83			
	NEM			NEM	
Art.-Nr.: 14724	UVP in €: 30,90				



Offener Güterwagen Ommk(u)
der K.Sächs.Sts.E.B.
Open car Ommk(u) of the
K.Sächs.Sts.E.B.

	83	□-□-□-□-□
NEM	→	NEM
Art.-Nr.14284		
UVP in €: 21,90		



Offener Güterwagen
Ommk(u) der K.Bay.Sts.B.
Open car Ommk(u) of the
K.Bay.Sts.B.

Handmuster

NEU	83	□-□-□-□-□
NEM	→	NEM
Art.-Nr: 14285		
UVP in €: 21,90		



Säuretopfwagen „Elektro-
Nitrum AG“, eingestellt bei
der Bad.St.B.
Acid pot car „Elektro-Nitrum
AG“ of the Bad.St.B.

	83	□-□-□-□-□
NEM	→	NEM
Art.-Nr: 14448		
UVP in €: 23,90		



Rungenwagen Rm der Bad.St.B.
Stake car Rm of the Bad.St.B.

Handmuster

NEU	96	□-□-□-□-□
NEM	→	NEM
Art.-Nr: 14632		
UVP in €: 18,50		



Dampflokomotive BR 23.0 der DRG
Steam locomotive class 23.0 of the DRG

191	oo oo	□-□-□-□-□	●●●●
NEM	→	NEM	NEM
Art.-Nr: 02101		UVP in €: 259,90	



Dampflokomotive BR 38.10 der DRG
Steam locomotive class 38.10 of the DRG

155	Rmin	□-□-□-□-□	●●●●
NEM	→	NEM	NEM
Art.-Nr: 02023		UVP in €: 289,90	



Dampflokomotive BR 50 der DRG
Steam locomotive class 50 of the DRG

	191		Rmin 310			
				NEM		NEM
Art.-Nr: 02094			UVP in €: 259,90			



Dampflokomotive BR 56.20 der DRG
Steam locomotive class 56.20 of the DRG

NEU		147				
				NEM		NEM
Art.-Nr: 02166			UVP in €: 221,50			



Dampflokomotive BR 86 der DRG
Steam locomotive class 86 of the DRG

NEU		113				
				NEM		NEM
Art.-Nr: 02181			UVP in €: 178,90			

Handmuster



Dampflokomotive BR 84 der DRG
Steam locomotive class 84 of the DRG

	130		Rmin 310			
				NEM		NEM
Art.-Nr: 02191			UVP in €: 234,90			

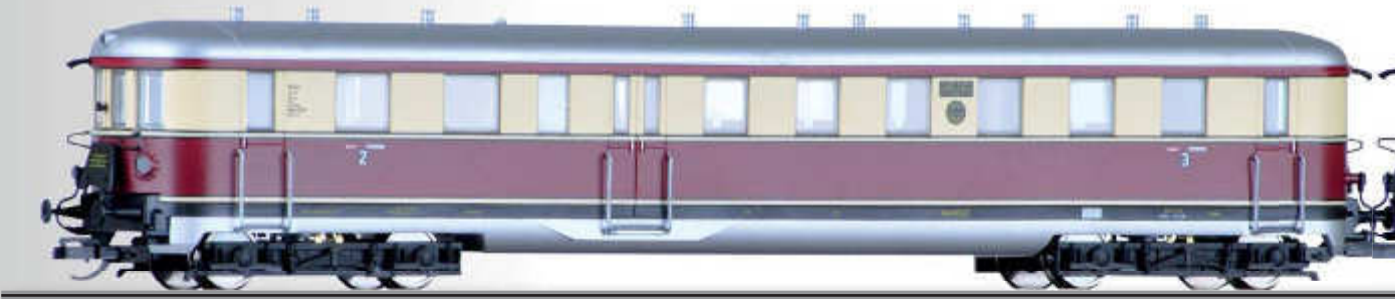

Triebwagen VT 137 mit Steuerwagen VS 145 der DRG
 Railbus class VT 137 with driving cab coach class VS 145 of the DRG



Elektr locomotive E 18 der DRG
 Electric locomotive class E 18 of the DRG

	142						
Art.-Nr: 02453				UVP in €: 178,90			



Personenwagen 2. Klasse (Bi-29)
 der DRG
 2nd class passenger coach (Bi-29)
 of the DRG

	116			
Art.-Nr: 13005				
UVP in €: 34,50				



Personenwagen 3. Klasse
 (Ci-30) der DRG
 3rd class passenger coach
 (Ci-30) of the DRG

	116			
Art.-Nr: 13208				
UVP in €: 26,50				



Packwagen Pw3 pr-11 der DRG
 Baggage car Pw3 pr-11 of the DRG

	110			
Art.-Nr: 13411				
UVP in €: 28,90				



Güterzuggepäckwagen Pwgs-41
 der DRG
 Baggage car Pwgs-41 of the DRG

NEU		86		
Art.-Nr: 13423				
UVP in €: 31,50				

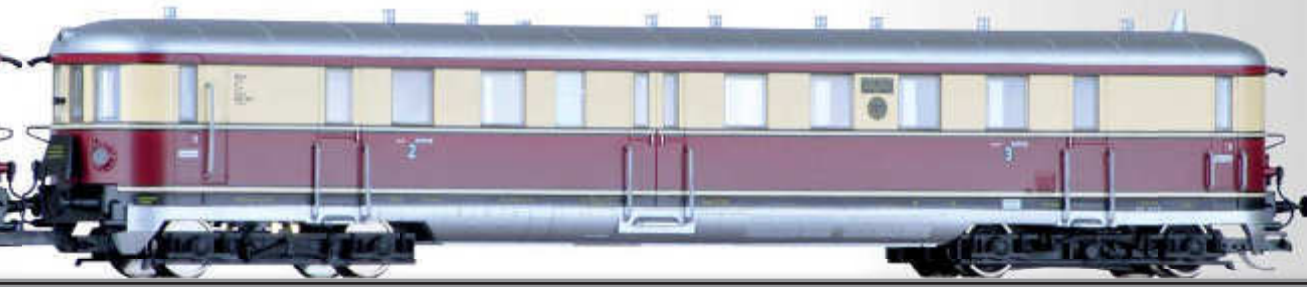

		365	⊕	⊖	⊕	⊖	⊕	⊖
	NEM							
Art.-Nr: 02854				UVP in €: 234,90				



Reisezugwagenset der DRG, bestehend aus zwei Schürzenwagen (1 x 2./3. Kl., 1 x 3. Kl.) und einem Postwagen Post4-b/15
 Passenger coach set of the DRG, with three different coaches (one 2nd/3rd class, one 3rd class and one mail car Post4-b/15)

		494	⊕	⊖	⊕	⊖	⊕	⊖
	NEM							
Art.-Nr: 01617				UVP in €: 146,90				



Postwagen Post4-b/15 der Deutschen Reichspost
Mail car Post4-b/15 of the German „Reichspost“

- Dachausführung mit Oberlichtern/with rooflight

		136	⚡	☐-☐-☐-☐
	NEM	NEM	NEM	NEM
Art.-Nr: 13891		UVP in €: 48,90		



Packwagen Pw4i-32 der DRG
Baggage car Pw4i-32 of the DRG

		175	⚡	☐-☐-☐-☐
	NEM	NEM	NEM	NEM
Art.-Nr: 13827		UVP in €: 41,50		



Reisezugwagen 1./2. Klasse AB4ü-39 der DRG
1st/2nd class passenger coach of the DRG

		177	⚡	☐-☐-☐-☐
	NEM	NEM	NEM	NEM
Art.-Nr: 16923		UVP in €: 49,90		



Güterwagenset DRG, bestehend aus: einem Kesselwagen
„Kriegsmarinewerft“, einem Niederbordwagen mit Plane, einem gedeckten
Güterwagen G Kassel
Freight car set of the DRG, with three different freight cars

		244	⚡	☐-☐-☐-☐
	NEM	NEM	NEM	NEM
Art.-Nr: 01673		UVP in €: 68,90		



Kesselwagen der Deutsch-Amerikanischen Petroleum-Gesellschaft, eingestellt bei der DRG
Tank car „Deutsch-Amerikanische Petroleum-Gesellschaft“ of the DRG

		76	■	→	□	■	□	■	□
	NEM	←	→	NEM					
Art.-Nr: 17302	UVP in €: 26,90								



Kesselwagen „Kriegsmarinewerft Wilhelmshaven“, eingestellt bei der DRG
Tank car „Kriegsmarinewerft Wilhelmshaven“ of the DRG

NEU		76	■	→	□	■	□	■	□
	NEM	←	→	NEM					
Art.-Nr: 17303	UVP in €: 26,90								



Kesselwagen der Wirtschaftlichen Forschungsgesellschaft, eingestellt bei der DRG
Tank car „Wirtschaftliche Forschungsgesellschaft“ of the DRG

		74	■	→	□	■	□	■	□
	NEM	←	→	NEM					
Art.-Nr: 95835	UVP in €: 30,90								



Schotterwagen der DRG
Hopper car of the DRG
• Mit geänderter Betriebsnummer /
With new car number

		58	■	→	□	■	□	■	□
	NEM	←	→	NEM					
Art.-Nr: 501285	UVP in €: 26,90								



Offener Güterwagen Om Breslau der DRG
Open box car Om Breslau of the DRG

		83	■	→	□	■	□	■	□
	NEM	←	→	NEM					
Art.-Nr: 14282	UVP in €: 21,90								



Weintransportwagen „Dt. Weinkesselwg.-Gesellschaft“, eingestellt bei der DRG
Wine barrel car of the DRG

	83	■	→	□	→	□	→	□	→	□	
NEM		NEM		NEM		NEM		NEM		NEM	
Art.-Nr: 14126											
UVP in €: 24,90											



Säuretopfwagen „IG Farbenindustrie“, eingestellt bei der DRG
Acid pot car „IG Farbenindustrie“ of the DRG

	83	■	→	□	→	□	→	□	→	□	
NEM		NEM		NEM		NEM		NEM		NEM	
Art.-Nr: 14446											
UVP in €: 23,90											



Rungenwagen R Stuttgart der DRG / Stake car R Stuttgart of the DRG

	96	■	→	□	→	□	→	□	→	□	
NEM		NEM		NEM		NEM		NEM		NEM	
Art.-Nr: 14658											
UVP in €: 18,50											



Säurekesselwagen „WIFO Berlin“, eingestellt bei der DRG
Acid tank car „WIFO Berlin“ of the DRG

NEU		74	■	→	□	→	□	→	□	→	□
NEM		NEM		NEM		NEM		NEM		NEM	
Art.-Nr: 14980											
UVP in €: 29,90											



Kühlwagen Gkhs der DRG
Refrigerator car Gkhs of the DRG

NEU		91	■	→	□	→	□	→	□	→	□
NEM		NEM		NEM		NEM		NEM		NEM	
Art.-Nr: 17001											
UVP in €: 26,90											



Kesselwagen „NITAG“, eingestellt bei der DRG
Tank car „NITAG“ of the DRG

	74	■	→	□	→	□	→	□	→	□	
NEM		NEM		NEM		NEM		NEM		NEM	
Art.-Nr: 95832											
UVP in €: 30,90											

- Ausführung mit weißem Kessel und ursprünglichen Firmenfarben Grün/Gelb / with white tank and origin company colours green/yellow



Kesselwagen „Benzin-Benzol-Verband“, eingestellt bei der DRG
Tank car „Benzin-Benzol-Verband“ of the DRG

NEU		74	■	→	□	→	□	→	□	→	□
NEM		NEM		NEM		NEM		NEM		NEM	
Art.-Nr: 95838											
UVP in €: 30,90											



Dampflokomotive BR 23.10 der DR
 Steam locomotive class 23.10 of the DR

NEU	NEM	191	Rmin 310	⊖ ⊕	→ ←	→ ←	•••••
Art.-Nr: 02051						UVP in €: 259,90	



Dampflokomotive BR 01 der DR mit Jubiläumseblem „800 Jahre
 Messe Leipzig“
 Steam locomotive class 01 of the DR

	NEM	199	⊖ ⊕	→ ←	→ ←	→ ←	•••••
Art.-Nr: 02135						UVP in €: 225,90	



Dampflokomotive BR 01.5 der DR
 Steam locomotive class 01.5 of the DR

- Mit Umlaufschürze und Boxpok-Treibradsätzen / with cover panel and Boxpok-Wheelsets

	NEM	199	⊖ ⊕	→ ←	→ ←	→ ←	•••••
Art.-Nr: 02004						UVP in €: 259,90	



Dampflokomotive BR 03.2 (Reko) der DR
 Steam locomotive class 03.2 (reconstructed) of the DR

	NEM	199	⊖ ⊕	→ ←	→ ←	→ ←	•••••
Art.-Nr: 02145						UVP in €: 259,90	



Dampflokomotive BR 38.10 der DR
Steam locomotive class 38.10 of the DR

	166		Rmin 310			
Art.-Nr: 02020		UVP in €: 289,90				

Dampflokomotive BR 38.10 der DR - *mit Sound*
Steam locomotive class 38.10 of the DR - *with sound*

- Mit Witte-Windleitblechen, Giesl-Ejektor und Tender 2'2'T 31,5/ with Witte smoke deflectors, Giesl-ejector and tender type 2'2'T 31,5

	166		Rmin 310			
Art.-Nr: 92653		UVP in €: 449,90				



Dampflokomotive BR 52 der DR
Steam locomotive class 52 of the DR

	193		Rmin 310			
Art.-Nr: 02287		UVP in €: 259,90				



Dampflokomotive BR 56 der DR
Steam locomotive class 56 of the DR

	147				
Art.-Nr: 02160		UVP in €: 221,50			



Dampflokomotive BR 86 der DR
Steam locomotive class 86 of the DR

	113				
Art.-Nr: 02179		UVP in €: 178,90			



Dampflokomotive BR 95 der DR
Steam locomotive class 95 of the DR

CAD

NEU		127	⊗	Rmin	⊗	⊗	⊗	⊗	⊗
	NEM	→	←	310	→	←	→	←	⊗
Art.-Nr: 03010					UVP in €: 249,90				



Diesellokomotive V 60.10-11 der DR
Diesel locomotive class V 60.10-11 of the DR

- Zusätzliche Lichteffekte bei Einsatz des Decoders 66017 / Additional lighting effects at digital use (only with decoder 66017)

		91	⊗	⊗	⊗	⊗	⊗	⊗	⊗
	NEM	→	←	→	←	→	←	→	⊗
Art.-Nr: 96112					UVP in €: 189,90				



Diesellokomotive V60 1256 der DR
Diesel locomotive class 60 1256 of the DR

Handmuster

NEU		91	⊗	⊗	⊗	⊗	⊗	⊗	⊗
	NEM	→	←	→	←	→	←	→	⊗
Art.-Nr: 96156					UVP in €: 168,90				



Diesellokomotive V 100 der DR
Diesel locomotive class V 100 of the DR

- Ursprungslackierung mit 2 Streifen / Original colouring with two stripes

		116	⊗	⊗	⊗	⊗	⊗	⊗	⊗
	NEM	→	←	→	←	→	←	→	⊗
Art.-Nr: 02582					UVP in €: 164,90				



Triebwagen VT 137 mit Steuerwagen VS 145 der DR
Railcar class VT 137/VS 145 of the DR

- unveränderte Wiederauflage



Steuerwagen VS 145 der DR
Driving cab coach VS 145 of the DR

		169					
Art.-Nr: 13301				UVP in €: 76,90			



Elektr locomotive E 18 der DR
Electric locomotive class E 18 of the DR

		141					
Art.-Nr: 02454 A				UVP in €: 178,90			



Diesellokomotive V180 059 der DR
Diesel locomotive class 180 059 of the DR
• Ausführung der Frontfenster: Panoramasscheiben mit Steg / With panoramic windows

NEU		162					
Art.-Nr: 02691				UVP in €: 175,90			



		365							
Art.-Nr: 02850					UVP in €: 234,90				



Personenwagen 2. Klasse (ex Bi-29) der DR
2nd class passenger coach (ex Bi-29) of the DR

		116							
Art.-Nr: 13001					UVP in €: 33,50				



Personenwagen 2. Klasse (ex BCi-29) der DR
2nd class passenger coach (ex BCi-29) of the DR

		116							
Art.-Nr: 13010					UVP in €: 33,50				



Packwagen (ex Pw3 pr-11) der DR
Baggage car (ex Pw3 pr-11) of the DR

		110							
Art.-Nr: 13412					UVP in €: 28,90				



Reisezugwagen 2. Klasse Bauart E5 der DR
2nd class passenger coach type E5 of the DR

		193			
Art.-Nr.: 13887		UVP in €: 42,90			



Reisezugwagen 1. Klasse (ex BC4ü-38) der DR
1st class passenger coach (ex BC4ü-38) of the DR

		177			
Art.-Nr.: 16900		UVP in €: 49,90			



Reisezugwagen 1./2. Klasse (ex BC4ü-38) der DR
1st/2nd class passenger coach (ex BC4ü-38) of the DR

		177			
Art.-Nr.: 16920		UVP in €: 49,90			



Reisezugwagen 2. Klasse (ex C4ü-38) der DR
2nd class passenger coach (ex C4ü-38) of the DR

		177			
Art.-Nr.: 16940		UVP in €: 49,90			



Speisewagen WR4ü-38 „MITROPA“ der DR
Dining car WR4ü-38 „MITROPA“ of the DR

		196			
Art.-Nr: 16970		UVP in €: 59,90			



Schlafwagen WLAB4ül-51 „MITROPA“ der DR
Sleeping coach WLAB4ül-51 „MITROPA“ of the DR

		177			
Art.-Nr: 16960		UVP in €: 55,50			



Reisezugwagen 1. Klasse, Typ B, der DR
1st class passenger coach, type B, of the DR

		204			
Art.-Nr: 16301		UVP in €: 44,90			



Reisezugwagen 2. Klasse, Typ B, der DR
2nd class passenger coach, type B, of the DR

		204			
Art.-Nr: 16341		UVP in €: 44,90			



Güterwagenset DR „Grundstoff-Industrie-Pendel 1“;
bestehend aus drei verschiedenen offenen Güterwagen
Freight car set of the DR with three different freight cars

		239	
Art.-Nr: 01683 A	UVP in €: 70,50		



FORMNEUHEIT: Güterwagenset „Militärtransport“ der DR, bestehend aus drei Niederbordwagen beladen mit verschiedenen LKW der NVA

NEW: Freight car set „military transport“ of the DR with three low side cars loaded with different trucks of the NVA

- Ergänzung zu Set 01627 / additional to set 01627



Güterwagenset DR „Grundstoff-Industrie-Pendel 2“;
bestehend aus drei verschiedenen offenen Güterwagen
Freight car set of the DR with three different freight cars

		239	
Art.-Nr: 01684 A	UVP in €: 70,50		



	NEU		292	
Art.-Nr: 01711	UVP in €: 109,90			

Handmuster



Güterwagenset, bestehend aus zwei Schwerlastwagen SSyms der DR, beladen mit Panzer T34/85 der sowjetischen Armee



Offener Güterwagen
Omu 36 der DR
Open car Omu 36
of the DR

		83	■	□	□
	NEM	←	→	NEM	
Art.-Nr: 14283	UVP in €: 21,90				



Klappdeckelwagen Kmm 21
der DR
Hinged cover car Kmm 21
of the DR

		76	■	□	□
	NEM	←	→	NEM	
Art.-Nr: 14712	UVP in €: 24,90				

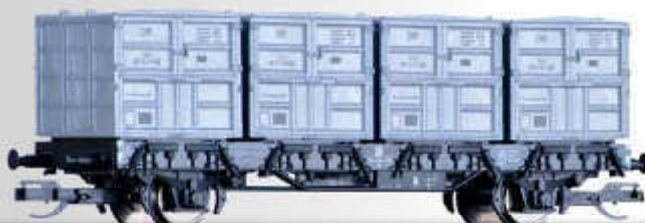

Behältertragwagen BT der DR
Container car BT of the DR

NEU		91	■	□	□
	NEM	←	→	NEM	
Art.-Nr: 14911	UVP in €: 26,90				



Freight car set with two flat cars SSyms of the DR loaded with tank type T34/85 of the Soviet Army

		222	■	→	□	←	□	□
	NEM	←	→	NEM				
Art.-Nr.: 01675	UVP in €: 107,90							



Säurekesselwagen Zd „VEB Farbenfabrik Wolfen“, eingestellt bei der DR
Acid tank car Zd „VEB Farbenfabrik Wolfen“ of the DR

NEU		74	■	→	□	←	□	□
	NEM	←	→	NEM				
Art.-Nr.: 14981	UVP in €: 29,90							

Handmuster



Gedecker Güterwagen GGrrts der DR
Box car GGrrts of the DR

•Mit geänderter Betriebsnummer / changed operation number

NEU		132	■	→	□	←	□	□
	NEM	←	→	NEM				
Art.-Nr.: 15115	UVP in €: 30,90							



Gedecker Güterwagen (ex G Kassel) der DR
Box car (ex G Kassel) of the DR

		83	■	→	□	←	□	□
	NEM	←	→	NEM				
Art.-Nr.: 17132 A	UVP in €: 24,90							



Gedeckter Güterwagen Mrs der DR
Box car Mrs of the DR

NEU		76	
Art.-Nr: 95215	UVP in €: 28,50		



Schienenreinigungswagen der DR
Rail cleaning car of the DR

- Ersatzschleifstück/
Bracket grinding stone: 390270

		91	
Art.-Nr: 95291	UVP in €: 42,50		



Schotterwagen Otmu der DR
Hopper car Otmu of the DR

		58	
Art.-Nr: 501273	UVP in €: 26,90		



Güterwagenset der DR, bestehend aus sechs verschiedenen Güterwagen (Niederbordwagen Xu, offener Güterwagen Omu, gedeckter Güterwagen Glxu, Kleinvieh-Verschlagwagen V, Säuretopfwagen Z, Klappdeckelwagen Kmm)



Güterwagenset „Militärtransport der NVA“ der DR, bestehend aus einem Mannschaftstransportwagen Mrs (ex. Oppeln) und zwei Schwerlastwagen SSyms beladen mit Panzer T 34/85

Freight car set „military transport“ of the DR with one box car Mrs (ex. Oppeln) and two flat cars SSyms loaded with two tanks type T 34/85

- Panzer mit drehbarem Turm und beweglicher Kanone / tank with turnable turret and moveable muzzle

	298	■-□-□-□
	NEM	NEM
Art.-Nr: 01627	UVP in €: 134,90	



Kesselwagen „VEB Teerverarbeitung Rositz“, eingestellt bei der DR
Tank car „VEB Teerverarbeitung Rositz“ of the DR

74	■-□-□-□
NEM	NEM
Art.-Nr: 95833	UVP in €: 29,90



Kesselwagen des VEB Sodawerk Bernburg, eingestellt bei der DR
Tank car VEB Sodawerk Bernburg of the DR

74	■-□-□-□
NEM	NEM
Art.-Nr: 95836	UVP in €: 29,90



Freight car set of the DR with six different freight cars (low side car Xu, open car Omu, box car Glxu, partition car for animal transport V, acid pot car Z, hinged cover car Kmm)

488	■-□-□-□
NEM	NEM
Art.-Nr: 01642	UVP in €: 104,90



Reko-Sitz-/Gepäckwagen 2. Klasse der DR
2nd class passenger coach with baggage compartment of the DR

Art.-Nr.: 16600				UVP in €: 48,90		



Dampflokomotive BR 01.5 der DR
Steam locomotive class 01.5 of the DR
• Mit Boxpok-Treibradsätzen und Öltender

NEU						
Art.-Nr.: 02005				UVP in €: 259,90		



Dampflokomotive BR 38.10 der DR
Steam locomotive class 38.10 of the DR

Art.-Nr.: 02025				UVP in €: 289,90		



Dampflokomotive BR 01 der DR
Steam locomotive class 01 of the DR

- Kurzgekuppelte feste Lok-Tender-Verbindung / close coupled and fixed connection locomotive – tender

Art.-Nr.: 02130				UVP in €: 225,90	



Dampflokomotive BR 03 der DR
Steam locomotive class 03 of the DR

- Kurzgekuppelte feste Lok-Tender-Verbindung / close coupled and fixed connection locomotive – tender

		Lok		Tender	
IV	199	⊖ ⊕	⊖ ⊕	⊖ ⊕	⊖ ⊕
NEM		NEM	NEM	NEM	NEM
Art.-Nr: 02146		UVP in €: 259,90			



Dampflokomotive 50 1387 der DR
Steam locomotive 50 1387 the DR

- Ausführung mit Witteblechen und Gieslschlot / with Witte smoke deflectors and Giesl-ejector

		Rmin			
IV	191	⊖ ⊕	310	⊖ ⊕	⊖ ⊕
NEM		NEM		NEM	NEM
Art.-Nr: 02096		UVP in €: 259,90			



Dampflokomotive BR 95 der DR
Steam locomotive class 95 of the DR

		Rmin		CAD	
NEU	127	⊖ ⊕	310	⊖ ⊕	⊖ ⊕
NEM		NEM		NEM	NEM
Art.-Nr: 03011		UVP in €: 249,90			



Diesellokomotive BR 106 der DR
Diesel locomotive class 106 of the DR

IV	91	⊖ ⊕	⊖ ⊕	⊖ ⊕	⊖ ⊕
NEM		NEM	NEM	NEM	NEM
Art.-Nr: 96151		UVP in €: 168,90			



Diesellokomotive BR 110 der DR
Diesel locomotive class 110 of the DR

	IV NEM1	116	⊕ ⊖	⊕ ⊖	⊕ ⊖	⊕ ⊖	⊕ ⊖	⊕ ⊖	⊕ ⊖	⊕ ⊖	⊕ ⊖	⊕ ⊖
Art.-Nr: 04589	UVP in €: 164,90											



Diesellokomotive BR 118 der DR
Diesel locomotive class 118 of the DR

	NEU	IV NEM1	162	⊕ ⊖	⊕ ⊖	⊕ ⊖	⊕ ⊖	⊕ ⊖	⊕ ⊖	⊕ ⊖	⊕ ⊖	⊕ ⊖
Art.-Nr: 02693	UVP in €: 175,90											



Diesellokomotive BR 119 „Kramermütze“ der DR
Diesel locomotive class 119 „Kramermütze“ of the DR

	IV NEM1	162	⊕ ⊖	⊕ ⊖	⊕ ⊖	⊕ ⊖	⊕ ⊖	⊕ ⊖	⊕ ⊖	⊕ ⊖	⊕ ⊖	⊕ ⊖
Art.-Nr: 02780	UVP in €: 166,90											



Elektr.lokomotive BR 218 der DR
Electric locomotive class 218 of the DR

	IV NEM1	141	⊕ ⊖	⊕ ⊖	⊕ ⊖	⊕ ⊖	⊕ ⊖	⊕ ⊖	⊕ ⊖	⊕ ⊖	⊕ ⊖	⊕ ⊖
Art.-Nr: 02450	UVP in €: 178,90											



Elektr locomotive BR 243 der DR
Electric locomotive class 243 of the DR

	IV NEM1	139						Flux12
Art.-Nr: 02375		UVP in €: 178,90						



Elektr locomotive BR 250 der DR
Electric locomotive class 250 of the DR

	IV NEM1	163						Flux12
Art.-Nr: 02337		UVP in €: 178,90						



Foto: W. Nitzsche

FORMNEUHEIT: Elektr locomotive BR 252 der DR

NEW: Electric locomotive class 252 of the DR

- Auslieferung erfolgt als DR-Locomotive der Baureihe 252 / Delivery class 252 of the DR

NEU	IV NEM1	163						Flux12
Art.-Nr: 04990		UVP in €: 178,90						



Elektr locomotive BR 211 der DR
Electric locomotive class 211 of the DR

	IV NEM1	135						Flux12
Art.-Nr: 501067		UVP in €: 178,90						



Elektrolokomotive BR 242 der DR
Electric locomotive class 242 of the DR

		Handmuster					
NEU	IV NEM	135					
Art.-Nr.: 501357		UVP in €: 178,90					



Reisezugwagen 2. Klasse der DR
2nd class passenger coach of the DR

			IV NEM	155			
Art.-Nr.: 16621		UVP in €: 44,90					



Reisezugwagenset der DR, bestehend aus Steuerwagen und Reisezugwagen
2. Klasse, Bauart E5
Passenger coach set of the DR with driving cab coach and 2nd class passenger
coach, type E5

• Ergänzung zu Art. 13888 / Additional to 13888

		Steuerwagen					
IV NEM	388						
Art.-Nr.: 01658		UVP in €: 121,50					



Reisezugwagen 2. Klasse, Bauart E5, der DR, mit geänderter Betriebsnummer
2nd class passenger coach type E5 of the DR, with different car number

• Ergänzung zu 01658 / Additional to 01658

			IV NEM	193			
Art.-Nr.: 13888		UVP in €: 42,90					



Reisezugwagenset „Autoreisezug Dresden-Budapest 1“ der DR, bestehend aus einem Liegewagen Typ B und einem Reko-Sitz-/Gepäckwagen
 Passenger coach set of the DR „Autoreisezug Dresden-Budapest 1“, with two different passenger coaches

• Ergänzung zu Art. 01661 / Additional to 01661

	361	
Art.-Nr: 01660		UVP in €: 90,50



Reisezugwagenset „Autoreisezug Dresden-Budapest 2“ der DR, bestehend aus zwei Schlafwagen WLAB (Typ B) und einem Autotransportwagen DDM, beladen mit drei Trabant 601 und drei Wartburg 353

Passenger coach set „Autoreisezug Dresden-Budapest 2“ of the DR, with two passenger coaches WLAB (type B) and one car DDM for automobile transport, loaded with six different cars

• Ergänzung zu Art. 01660 / Additional to 01660

	632	
Art.-Nr: 01661		UVP in €: 189,50



Reisezugwagenset der DR „Tourex 1“; bestehend aus drei verschiedenen Reisezugwagen Typ B

Passenger coach set of the DR „Tourex 1“, with three different passenger coaches type B

- Ergänzung zu Set 01698 / Additional to set 01698

		621		
Art.-Nr: 01662	UVP in €: 140,50			



Reisezugwagenset „Tourex 2“ der DR, bestehend aus zwei Schlafwagen und einem Vorratswagen, Typ B

Passenger coach set „Tourex 2“ of the DR with two sleeping coaches and one service coach, type B

- Ergänzung zu Set 01662 / Additional to set 01662

NEU		616		
Art.-Nr: 01698	UVP in €: 140,50			



Reisezugwagenset der DR „Städteexpress“; bestehend aus zwei Reisezugwagen Bme, Bauart Halberstadt
 Passenger coach set of the DR „Städteexpress“; with two different passenger coaches Bme, type Halberstadt

	IV NEM	442	→	☐-☐-☐-☐-☐	☐-☐-☐-☐-☐ NEM
Art.-Nr: 501287	UVP in €: 92,90				



Reisezugwagen 1. Klasse Am, Bauart Halberstadt, der DR
 1st class passenger coach Am, type Halberstadt, of the DR
 • Mit geänderter Betriebsnummer / Changed operation number

NEU	☐-☐-☐-☐-☐	IV NEM	220	→	☐-☐-☐-☐-☐	☐-☐-☐-☐-☐ NEM
Art.-Nr: 501409	UVP in €: 47,90					



Reisezugwagen 1./2. Klasse ABm, Bauart Halberstadt, der DR
 1st / 2nd class passenger coach ABm, type Halberstadt, of the DR
 • Mit geänderter Betriebsnummer / Changed operation number

NEU	☐-☐-☐-☐-☐	IV NEM	220	→	☐-☐-☐-☐-☐	☐-☐-☐-☐-☐ NEM
Art.-Nr: 501410	UVP in €: 47,90					



Reisezugwagen 2. Klasse Bm, Bauart Halberstadt, der DR
 2nd class passenger coach Bm, type Halberstadt, of the DR
 • Mit geänderter Betriebsnummer / Changed operation number

NEU	☐-☐-☐-☐-☐	IV NEM	220	→	☐-☐-☐-☐-☐	☐-☐-☐-☐-☐ NEM
Art.-Nr: 501411	UVP in €: 47,90					



Reisezugwagen 2. Klasse, Bauart Halberstadt, der DR
2nd class passenger coach, type Halberstadt, of the DR

- Ausführung mit rehbraunem Dach / with fawn brown roof

	IV NEM	220			
Art.-Nr: 13593			UVP in €: 45,90		



Steuerwagen 2. Klasse Bghqe der DR
2nd class driving cab coach Bghqe of the DR

NEU	IV NEM	193				
Art.-Nr: 13873			UVP in €: 81,50			



Reisezugwagen 2. Klasse Bghe der DR
2nd class passenger coach Bghe of the DR

NEU		IV NEM	193			
Art.-Nr: 13879			UVP in €: 42,90			



Reisezugwagen 2. Klasse Bghe der DR
2nd class passenger coach Bghe of the DR

NEU		IV NEM	193			
Art.-Nr: 13889			UVP in €: 42,90			



Speisewagen „MITROPA“ der DR
Dining car „MITROPA“ of the DR

	IV NEM	155				
Art.-Nr: 16750 A			UVP in €: 49,90			



Reisezugwagen 1. Klasse, Typ Y/B 70, der DR
1st class passenger coach type Y/B 70 of the DR

Art.-Nr: 16660			UVP in €: 45,90			



Sitz-/Gepäckwagen 2. Klasse, Typ Y/B 70, der DR
2nd class passenger coach with baggage compartment, type Y/B 70, of the DR

Art.-Nr: 16696			UVP in €: 49,90			



Reisezugwagen 1./2. Klasse, Typ Y/B 70, der DR
1st/2nd class passenger coach type Y/B 70 of the DR

Art.-Nr: 16661			UVP in €: 45,90			



Liegewagen 2. Klasse, Typ Y/B 70, der DR
2nd class couchette coach, type Y/B 70, of the DR

Art.-Nr: 16650			UVP in €: 45,90			



Reisezugwagen 2. Klasse, Typ Y/B 70, der DR
2nd class passenger coach, type Y/B 70, of the DR

Art.-Nr: 16652			UVP in €: 45,90			



Set der DR, bestehend aus drei Autotransportwagen DDm
Set of the DR with three different cars DDm for automobile transport

		664		
Art.-Nr: 01636	UVP in €: 124,90			



Autotransportwagen DDm der DR
Car DDm of the DR for automobile transport

• Ergänzung zu Art. 01636 / additional to set 01636

		220		
Art.-Nr: 15050	UVP in €: 42,50			



Güterwagenset der DR, bestehend aus sechs verschiedenen Güterwagen
Freight car set of the DR, with six different freight cars



Packwagen Pwgs 56 der DR
Baggage car Pwgs 56 of the DR

IV	76	□-□-□-□
NEM	← →	NEM
Art.-Nr: 13426		
UVP in €: 22,90		



Offener Güterwagen Es 5520 der DR
Open car Es 5520 of the DR

IV	83	□-□-□-□
NEM	← →	NEM
Art.-Nr: 17242		
UVP in €: 17,50		



IV	488	□-□-□-□
NEM	← →	NEM
Art.-Nr: 01643		UVP in €: 104,90



Postzugset der DR, bestehend aus einem Reko-Postwagen, einem Güterwagen Gbs und einem Containertragwagen Rgs beladen mit drei unterschiedlichen Containern

Post wagon set of the DR with one mail wagon, one box car Gbs and one container car Rgs loaded with three different containers

	IV NEU	397	← →	■ □	□ □ □ □	NEU
Art.-Nr.: 01671		UVP in €: 104,90				



FORMNEUHEIT: Güterwagenset „Militärtransport“ der DR, bestehend aus einem Niederbordwagen Res, beladen mit zwei LKW und einem gedeckten Güterwagen Gbs-t 1530

NEW: Freight car set „military transport“ of the DR with one low side car Res loaded with trucks and one box car Gbs-t 1530

	NEU	IV NEU	285	← →	■ □	□ □ □ □	NEU
Art.-Nr: 01712		UVP in €: 99,90					



Güterwagenset der DR, bestehend aus drei gedeckten Güterwagen (1x Gbs 1500, 1x Gbs 1550, 1x Hbs 2300)
 Freight car set of the DR with three box cars (1x Gbs 1500, 1x Gbs 1550, 1x Hbs 2300)

- Bauart Gbs 1500 / box car type Gbs 1500
- Gedeckter Güterwagen Hbs 2300 ohne Inneneinrichtung / box car Hbs 2300 without interior

	IV NEM	355	■ → □	□ → □
Art.-Nr: 01631 A	UVP in €: 111,50			



Säuretopfwagen der DR
 Acid pot car of the DR

	IV NEM	83	■ → □	□ → □
Art.-Nr: 14447	UVP in €: 23,90			



Schwenkdachwagen Tds „Plaste aus Schkopau“ der DR
 Swing roof car Tds „Plaste aus Schkopau“ of the DR

- Mit neuer Betriebsnummer /
 With new operation number

	IV NEM	81	■ → □	□ → □
Art.-Nr: 14571	UVP in €: 36,50			



Schwenkdachwagen Tdgs für Getreidetransport der DR
Swing roof car Tdgs „Getreide“ of the DR

- Mit neuer Betriebsnummer /
With new operation number

	IV NEM	81	□-□-□-□
Art.-Nr: 14574	UVP in €: 36,50		



Selbstentladewagen Fcs 6450 der DR
Hopper car Fcs 6450 of the DR

	IV NEM	81	□-□-□-□
Art.-Nr: 14587	UVP in €: 36,50		



Wagenset „Bauzug“ der DR
Car set „Bauzug“ of the DR

	IV NEM	292	□-□-□-□
Art.-Nr: 01705	UVP in €: 71,50		

Handmuster



Werkstattwagen zum Bauzug 31 der DR
Freight car for Bauzug 31 of the DR

- Ergänzung zu Set 01705 / Additional to set 01705

NEU	IV NEM	91	□	□	□	□	□
Art.-Nr: 13295	UVP in €: 33,50						

Handmuster



Offener Güterwagen Eas 5969 der DR mit Pressblech Türen
Open car Eas 5969 of the DR with pressure plate doors

	IV NEM	117	□	□	□	□	□
Art.-Nr: 15246	UVP in €: 33,50						



Selbstentladewagen Fal 6551 der DR
Hopper car Fal 6551 of the DR

NEU	IV NEM	108	□	□	□	□	□
Art.-Nr: 15283	UVP in €: 30,50						

Handmuster



Schwenkdachwagen Tadgs-y 5843 der DR
Swing roof car Tadgs-y 5843 of the DR

	IV NEM	159	□	□	□	□	□
Art.-Nr: 15350	UVP in €: 47,50						



Selbstentladewagen Facs 6941 der DR
Hopper car Facs 6941 of the DR

	IV NEM	159	□	□	□	□	□
Art.-Nr: 15370	UVP in €: 43,90						



Güterwagenset der DR, bestehend aus drei verschiedenen Staubsilowagen Uacs-y 9324
Freight car set of the DR with three different silo cars Uacs-y 9324

Handmuster

NEU	IV	481	<input type="checkbox"/> <input type="checkbox"/> <input type="checkbox"/> <input type="checkbox"/>	
	NEM		<input type="checkbox"/> NEM	
Art.-Nr: 01717		UVP in €: 133,50		



Staubbehälterwagen Uacs-x 9308 der DR
Silo car Uacs-x 9308 of the DR

	IV	159	<input type="checkbox"/> <input type="checkbox"/> <input type="checkbox"/> <input type="checkbox"/>	
	NEM		<input type="checkbox"/> NEM	
Art.-Nr: 15488		UVP in €: 44,90		



Kühlwagen Ibbhqss 8362 der DR
Refrigerator car Ibbhqss 8362 of the DR

	IV	117	■	→	☐	☐
	NEM	→	→		NEM	
Art.-Nr: 14690 A		UVP in €: 38,50				



Kühlwagen Ibbehs der INTERFRIGO, eingestellt bei der DR
Refrigerator car INTERFRIGO of the DR

	IV	117	■	→	☐	☐
	NEM	→	→		NEM	
Art.-Nr: 14694		UVP in €: 38,50				



Schwenkdachwagen Tbekks 5775 der DR
Swing roof wagon Tbekks 5775 of the DR

	IV	120	■	→	☐	☐
	NEM	→	→		NEM	
Art.-Nr: 17153		UVP in €: 41,90				



Gedeckter Güterwagen Gbs 1500 der DR
Box car Gbs 1500 of the DR

	NEU	IV	117	■	→	☐
		NEM	→	→		NEM
Art.-Nr: 17164		UVP in €: 37,90				

Handmuster



FORMNEUHEIT: Niederbordwagen Res der DR, beladen mit zwei Lkw Robur LO 1801 Kofferaufbau der NVA
NEW: Low side car Res of the DR, with two Military van trucks type Robur LO1801

	IV NEM	166	■-□-□-□-□
Art.-Nr: 18101	UVP in €: 64,90		



Containertragwagen Rgs-z der DR, beladen mit drei verschiedenen 20" Containern / Container car Rgs-z of the DR, loaded with three different 20" container

	IV NEM	166	■-□-□-□-□
Art.-Nr: 18102 A	UVP in €: 37,90		



Niederbordwagen Res der DR
 Low side car Res of the DR

- Ausführung der späten Epoche IV mit braunem Fahrwerk / Model of the late epoch IV with brown chassis

	IV NEM	166	■-□-□-□-□
Art.-Nr: 15581	UVP in €: 28,50		



Kesselwagen Zacs der DR
 Tank car Zacs of the DR

	IV NEM	120	■-□-□-□-□
Art.-Nr: 15431	UVP in €: 39,90		



FORMNEUHEIT: Güterwagenset, bestehend aus zwei Gaskesselwagen Zagkk „VEB PCK Schwedt“ mit Sonnenschutzdach, eingestellt bei der DR
NEW: Freight car set with two gas tank car Zagkk “VEB PCK Schwedt” with sunshield of the DR

- Endgültige Gestaltung stand bei Drucklegung noch nicht fest / Final design will be announced

Handmuster	NEU	IV	306	■-□-□-□
		NEM		NEM
Art.-Nr: 01718		UVP in €: 88,90		



FORMNEUHEIT: Gaskesselwagen Uah / Zagk mit Sonnenschutzdach der DR
NEW: Gas tank car Uah / Zagk with sunshield of the DR

- Endgültige Gestaltung stand bei Drucklegung noch nicht fest / Final design will be announced

Handmuster	NEU	IV	120	■-□-□-□
		NEM		NEM
Art.-Nr: 15000		UVP in €: 44,90		



Kesselwagen Zh „VEB Teerverarbeitungswerk Rositz“, eingestellt bei der DR
 Tank car Zh „VEB Teerverarbeitungswerk Rositz“ of the DR

Handmuster	NEU	IV	92	■-□-□-□
		NEM		NEM
Art.-Nr: 17401		UVP in €: 36,50		



Kesselwagen der DR, vermietet an „VEB Kombinat Schwarze Pumpe“
 Tank car of the DR, rented to „VEB Kombinat Schwarze Pumpe“

Handmuster	NEU	IV	74	■-□-□-□
		NEM		NEM
Art.-Nr: 95847		UVP in €: 30,90		



Güterwagenset der DR, bestehend aus drei Staubsilowagen Ucs mit unterschiedlichen Betriebsnummern
 Freight car set of the DR, with three different silo cars with different car numbers

	IV NEM	214	■ → □ □ □ □
Art.-Nr.: 01680	UVP in €: 99,50		



Staubsilowagen Ucs der DR
 Silo car Ucs of the DR

	IV NEM	72	■ → □ □ □ □
Art.-Nr.: 17700	UVP in €: 33,50		



Güterwagenset „VEB Leuna-Werke Walter Ulbricht“, bestehend aus zwei gedeckten Güterwagen Gbs, eingestellt bei der DR
 Freight car set „VEB Leuna-Werke Walter Ulbricht“ with two box cars Gbs of the DR

	IV NEM	236	■ → □ □ □ □
Art.-Nr.: 501324	UVP in €: 74,50		



Reisezugwagenset der DR, bestehend aus drei verschiedenen InterRegio-Wagen: 2x Bomz; 1x ARkimbz (Bistro Café)

Passenger coach set of the DR, with three different passenger coaches

- Unterschiedliche DR-Logos / Different DR-Logos

V	664	NEM	→	←	→	←	→	←	→
Art.-Nr: 501286					UVP in €: 148,90				



Foto: TILLIG Werksarchiv



Dampflokomotive 50 2840 der DB
Steam locomotive 50 2840 of the DB

		Handmuster	
NEU	 NEM1	191 ← →	⊗ ⊙ Rmin 310
		■ □ ▣ ▤ ▥	● ● ● ● ● ● NEM
Art.-Nr: 02097		UVP in €: 259,90	



Diesellokomotive V200.0 der DB
Diesel locomotive class 200.0 of the DB

- Mit erhabenem Schriftzug „Deutsche Bundesbahn“ / with raised letters „Deutsche Bundesbahn“

		Handmuster	
	 NEM1	152 ← →	⊗ ⊙ Rmin 310
		■ □ ▣ ▤ ▥	● ● ● ● ● ● NEM
Art.-Nr: 02501		UVP in €: 175,90	



Diesellokomotive V36 122 der DB
Diesel locomotive V36 122 of the DB

		Handmuster	
NEU	 NEM1	77 ← →	⊗ ⊙ Rmin 310
		■ □ ▣ ▤ ▥	● ● ● ● ● ● NEM
Art.-Nr: 04637		UVP in €: 146,90	



Diesellokomotive V100.10 der DB
Diesel locomotive class 100.10 of the DB

		Handmuster	
NEU	 NEM1	103 ← →	⊗ ⊙ Rmin 310
		■ □ ▣ ▤ ▥	● ● ● ● ● ● NEM
Art.-Nr: 501351		UVP in €: 158,50	



Elektrolokomotive E 40 der DB
Electric locomotive class E 40 of the DB

Art.-Nr: 02394		UVP in €: 175,90			



Elektrolokomotive E 18 der DB
Electric locomotive class E 18 of the DB

NEU						
Art.-Nr: 02457		UVP in €: 178,90				



Foto: S. Klein



Leser und Redaktion der Zeitschrift **EISENBahn MAGAZIN** wählen zum

MODELL DES JAHRES 2013

In der Kategorie: **F7-Fahrzeuge**
Rheingold-Reisezug mit E 10.12 DB
 10.120 Modellbahnen GmbH, Berlin
 Diese Zugpartner hat Kulturstil und ist im Maßstab 1:125 leicht überlappig. Die Umsetzung überzeugt sowohl durch Farbgebung als auch durch ihre Detaillierung.

Mit dieser Wahl zum **MODELL DES JAHRES** wird durch die Leser der Zeitschrift ein Produkt gewürdigt, das den hohen Stand heutiger Modellbahntechnik repräsentiert.

eisenbahn
 Modellbahn magazin



Reisezugwagenset „Rheingold 1“ der DB, bestehend aus Elektrolokomotive E 10.12 und zwei Reisezugwagen (AD4üm-62 und Av4üm-62)
 Passenger coach set „Rheingold 1“ of the DB with electric locomotive class E 10.12 and two different passenger coaches (AD4üm-62 und Av4üm-62)

		575			
Art.-Nr: 01614			UVP in €: 276,50		



Reisezugwagen 1. Klasse Av4üm-62 der DB
 1st class passenger coach Av4üm-62 of the DB
 • Ergänzung zu Sets 01614 und 01651 / additional to sets 01614 and 01651

NEU			220		
Art.-Nr: 13587			UVP in €: 48,90		



Reisezugwagen set „Rheingold 2“ der DB, bestehend aus drei verschiedenen Reisezugwagen (Speisewagen WR4üm-62, Reisezugwagen Av4üm-62 und Ap4üm-62)

Passenger coach set „Rheingold 2“ of the DB, with three different passenger coaches (dining car WR4üm-62, passenger coaches Av4üm-62, Ap4üm-62)

WR4üm	
	
	
Art.-Nr: 01651	UVP in €: 150,90



Foto: Stefan Klein



Reisezugwagen set der DB, bestehend aus drei Schürzenwagen in F-Zug-Lackierung
 Passenger coach set of the DB with three different passenger coaches in F-Zug-colouring

III NEM	535	E	☰	☐-☐-☐-☐ NEM
Art.-Nr: 01595 A		UVP in €: 154,50		



Speisewagen (Schürzenwagen) der DB
 Dining car of the DB

- Ergänzungswagen zu Set 01595 / compatible to set 01595

III NEM	196	E	☰	☐-☐-☐-☐ NEM
Art.-Nr: 16975 A		UVP in €: 59,90		



Reisezugwagen 1./2. Klasse (Schürzenwagen) der DB
 1st/2nd passenger coach of the DB

- Ergänzungswagen zu Set 01595 / compatible to set 01595

III NEM	177	E	☰	☐-☐-☐-☐ NEM
Art.-Nr: 16922 A		UVP in €: 49,90		



Güterzuggepäckwagen Pwgs-41 der DB
Baggage car Pwgs-41 of the DB

	III NEM	IV NEM	86	■ → □ ← □
Art.-Nr: 13476	UVP in €: 31,50			



Behelfs-Güterzuggepäckwagen (ex Bi-29) der DB
Baggage car (ex Bi-29) of the DB

	III NEM	116	■ → □ ← □
Art.-Nr: 16001	UVP in €: 33,50		



Reisezugwagenset „RTC-Militärzug 1“, bestehend aus zwei Liegewagen mit unterschiedlichen Betriebsnummern
Passenger coach set "RTC Militärzug 1", with two couchette coaches with different numbers

NEU	III NEM	442	■ → □ ← □
Art.-Nr: 01693	UVP in €: 102,90		



Reisezugwagenset der DB, bestehend aus zwei verschiedenen Reisezugwagen (AB4üm, B4üm) und einem Speisewagen (WR4üm-64)



Reisezugwagen 1. Klasse der DB
1st class passenger coach of the DB

				220		
Art.-Nr.: 13518	UVP in €: 47,90					



Sitz-/Gepäckwagen 2. Klasse der DB
2nd class passenger coach with baggage compartment of the DB

				220		
Art.-Nr.: 13519	UVP in €: 47,90					



Liegewagen 2. Klasse Bc4üm-62 der DB
2nd class couchette coach Bc4üm-62 of the DB

NEU			220		
Art.-Nr.: 16581	UVP in €: 52,50				



Passenger coach set of the DB, with two different passenger coaches (AB4üm, B4üm) and one dining car (WR4üm-64)

			664			
Art.-Nr: 01623		UVP in €: 153,50				



Steuerwagen „Silberling“ BD4nf der DB
Driving cab coach „Silberling“ BD4nf of the DB

- Warm-weiße LED-Beleuchtung am Steuerabteil/warm-white LED at the front

	220					
Art.-Nr: 13830		UVP in €: 65,50				



Reisezugwagen 1./2. Klasse „Silberling“ AB4n der DB
1st/2nd class passenger coach „Silberling“ AB4n of the DB

		220		
Art.-Nr: 13851		UVP in €: 41,50		



Reisezugwagen 2. Klasse „Silberling“ B4n der DB
2nd class passenger coach „Silberling“ B4n of the DB

		220		
Art.-Nr: 13850		UVP in €: 41,50		



Handmuster

Kühlwagen Tnos 34 „Bananen“
der DB
Refrigerator car Tnos 34
„Bananen“ of the DB
• Freelance Modell auf Basis
Kühlwagen (z. B. 14108) / Freelance
model based on refrigerator car (14108)

NEU		91	■	□	□	□
	NEM	←	→	←	→	←
Art.-Nr: 14110	UVP in €: 26,90					



Schwenkdachwagen Ktmms 69
der DB
Swing roof car Ktmms 69 of the
DB

		81	■	□	□	□
	NEM	←	→	←	→	←
Art.-Nr: 14576	UVP in €: 36,50					



Selbstentladewagen Otmm 70
der DB
Hopper car Otmm 70 of the DB

		81	■	□	□	□
	NEM	←	→	←	→	←
Art.-Nr: 14586	UVP in €: 36,50					



Kühlwagen „Brauerei J.G. Reif
AG“, eingestellt bei der DB
Refrigerator car „Brauerei J.G. Reif
AG“ of the DB

NEU		91	■	□	□	□
	NEM	←	→	←	→	←
Art.-Nr: 17002	UVP in €: 26,90					



Gedeckter Güterwagen Glmms 61 der DB

Box car Glmms 61 of the DB

- Mit beweglichen Türen /
With moveable doors

		117	■	→	□	→	□	→	□
	NEM	→	→	NEM					
Art.-Nr: 17150 A	UVP in €: 37,90								



Gedeckter Güterwagen Glmms 64 der DB

Box car Glmms 64 of the DB

- Mit beweglichen Türen /
With moveable doors

		117	■	→	□	→	□	→	□
	NEM	→	→	NEM					
Art.-Nr: 17155 A	UVP in €: 37,90								



Gedeckter Güterwagen Gltmms 62 der DB

Box car Gltmms 62 of the DB

- Mit beweglichen Türen /
With moveable doors

		117	■	→	□	→	□	→	□
	NEM	→	→	NEM					
Art.-Nr: 17156	UVP in €: 37,90								



Offener Güterwagen Omm 55 der DB

Open car Omm 55 of the DB

		83	■	→	□	→	□	→	□
	NEM	→	→	NEM					
Art.-Nr: 17245	UVP in €: 17,50								



Schotterwagen der DB
Hopper car of the DB

NEU		58	■	→	□	→	□	→	□
	NEM	→	→	NEM					
Art.-Nr: 17500	UVP in €: 26,90								



Niederbordwagen Xt 35 der DB, beladen mit Matador „DSG“
Low side car Xt 35 of the DB, with Matador van „DSG“

		76	■	→	←	⊞
	NEM					NEM
Art.-Nr: 14923	UVP in €: 28,50					



Kühlwagen „Petri Fischkonserven“, eingestellt bei der DB
Refrigerator car „Petri Fischkonserven“ of the DB

		81	■	→	←	⊞
	NEM					NEM
Art.-Nr: 17134	UVP in €: 26,90					



Staubsilowagen Kds 54 der DB
Silo car Kds 54 of the DB

		72	■	→	←	⊞
	NEM					NEM
Art.-Nr: 17731	UVP in €: 33,50					



Staubsilowagen Kds 56 der DB
Silo car Kds 56 of the DB

NEU		72	■	→	←	⊞
	NEM					NEM
Art.-Nr: 17762	UVP in €: 33,50					



FORMNEUHEIT: Gaskesselwagen „EVA“ mit Sonnenschutzdach, eingestellt bei der DB

NEW: Gas tank car „EVA“ with sunshiled of the DB

- Endgültige Gestaltung stand bei Drucklegung noch nicht fest / Final design will be announced

NEU	 NEM	120	■-□-□-□-□-□ NEM
Art.-Nr: 15002	UVP in €: 44,90		



Kesselwagen „GASOLIN“, eingestellt bei der DB

Tank car „GASOLIN“ of the DB

NEU	 NEM	76	■-□-□-□-□-□ NEM
Art.-Nr: 17304	UVP in €: 26,90		



Kesselwagen „DEA“, eingestellt bei der DB

Tank car „DEA“ of the DB

- Mit neuer Betriebsnummer erhältlich / with new car number

NEU	 NEM	74	■-□-□-□-□-□ NEM
Art.-Nr: 95830 A	UVP in €: 30,90		



Kesselwagen „EVA“, eingestellt bei der DB

Tank car „EVA“ of the DB

NEU	 NEM	74	■-□-□-□-□-□ NEM
Art.-Nr: 95839	UVP in €: 30,90		



Kesselwagen „Bolte & Co. KG“, eingestellt bei der DB

Tank car „Bolte & Co. KG“ of the DB

NEU	 NEM	74	■-□-□-□-□-□ NEM
Art.-Nr: 95846	UVP in €: 30,90		



Güterwagenset EUROP, bestehend aus je einem gedeckten Güterwagen der DB, der SNCB und der SNCF
 Freight car set EUROP, with three different box cars (one DB, one SNCB, one SNCF)

III	232	□-□-□-□
NEM	← →	NEM

Art.-Nr: 01652 UVP in €: 74,50



Foto: TILLIG Werksarchiv (Abb. zeigt DR-Ausführung)



Wagenset „Bauzug“ der DB
 Car set „Bauzug“ of the DB

III	272	□-□-□-□
NEM	← →	NEM

Art.-Nr: 01664 UVP in €: 71,50



Güterwagenset der DB, bestehend aus sechs verschiedenen Güterwagen (Niederbordwagen X05, offener Güterwagen Om12, offener Güterwagen Om55, Kleinvieh-Verschlagwagen V23, Säuretopfwagen „EVA“, gedeckter Güterwagen G10)

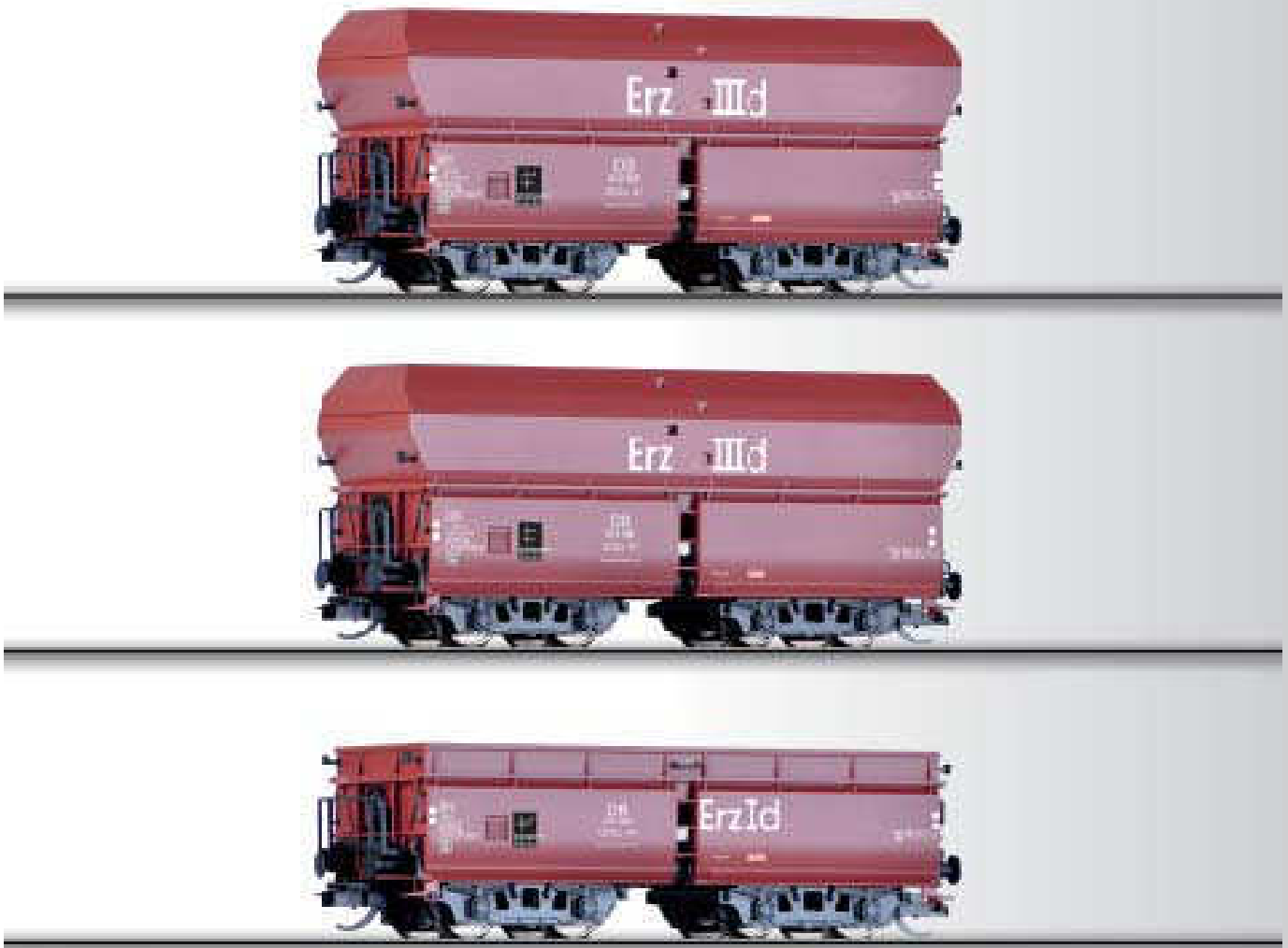

FORMNEUHEIT: Güterwagenset „Erzzug 1“ der DB, bestehend aus drei unterschiedlichen Selbstentladewagen OOtz 41 und OOtz 44

NEW: Freight car set „Erzzug 1“ of the DB with three different hopper cars OOtz 41 and OOtz 44



- Weitere Ergänzungen folgen / Additional sets in preparation

Handmuster

NEU	 253 	
Art.-Nr: 01710	UVP in €: 99,50	



Freight car set of the DB with six different freight cars (low side car X05, open car Om12, open car Omm55, partition car for animal transport V23, acid pot car „EVA“, box car G10)

 480 	
Art.-Nr.: 01644	UVP in €: 104,90



Dampflokomotive BR 038 der DB
Steam locomotive class 038 of the DB

- Ausführung mit Witte-Windleitblechen, Indusi und Tender 2'2'T 21,5/
version with Witte smoke deflectors, Indusi train protection and tender type 2'2'T 21,5

IV NEM	155 ← →	oo ••	Rmin 310	← →	← →	••••
		NEM	NEM	NEM	NEM	NEM G6
Art.-Nr: 02021			UVP in €: 289,90			



Dampflokomotive BR 001 der DB
Steam locomotive class 001 of the DB

IV NEM	199 ← →	oo ••	Lok ← →	Tender ← →	••••	
		NEM	NEM	NEM	NEM	
Art.-Nr: 02133			UVP in €: 225,90			



Dampflokomotive BR 050 der DB
Steam locomotive class 050 of the DB

IV NEM	191 ← →	oo ••	Rmin 310	← →	← →	••••
		NEM	NEM	NEM	NEM	NEM
Art.-Nr: 02295			UVP in €: 259,90			



Dampflokomotive 86 457
des DB-Museums
Steam locomotive 86 457
of the DB-museum

IV NEM	113 ← →	oo ••	← →	← →	••••	
		NEM	NEM	NEM	NEM	
Art.-Nr: 02178			UVP in €: 178,90			



Diesellokomotive BR 220 der DB
Diesel locomotive class 220 of the DB

IV NEM	152				
Art.-Nr: 02500 A		UVP in €: 166,90			



Diesellokomotive BR 220 der DB
Diesel locomotive class 220 of the DB

IV NEM	152				
Art.-Nr: 02503 A		UVP in €: 166,90			



Diesellokomotive 219 001-5 der DB
Diesel locomotive class 219 001-5 of the DB

IV NEM	137				
Art.-Nr: 02741		UVP in €: 166,90			



Diesellokomotive BR 280 der DB
Diesel locomotive class 280 of the DB

IV NEM	108				
Art.-Nr: 04801		UVP in €: 168,90			



Elektrolokomotive BR 139 der DB
Electric locomotive class 139 of the DB

NEU	IV NEM1	135					
Art.-Nr: 02397				UVP in €: 175,90			



Elektrolokomotive BR 118 der DB
Electric locomotive class 118 of the DB

	IV NEM1	141					
Art.-Nr: 02451 A				UVP in €: 178,90			



Elektrolokomotive BR 118 der DB
Electric locomotive class 118 of the DB

	IV NEM1	141					
Art.-Nr: 02455				UVP in €: 178,90			



Handmuster

Reisezugwagenset „USTC-Militärzug 1“, bestehend aus zwei Liegewagen
Passenger coach set „USTC-Militärzug 1“ with two couchette coaches

- Weitere Ergänzung folgen / additional sets in preparation

NEU	IV NEM	442 →				
Art.-Nr: 01692	UVP in €: 102,90					



Reisezugwagen 2. Klasse Bye 655 der DB
2nd class passenger coach Bye 655 of the DB

NEU		IV NEM	175 →						
Art.-Nr: 13315	UVP in €: 38,90								



Reisezugwagen 2. Klasse mit Gepäckabteil, BDm, der DB
2nd class passenger coach with baggage compartment BDm of the DB

		IV NEM	220 →						
Art.-Nr: 13526	UVP in €: 47,90								



Speisewagen WRm 132 der DB
Dining car WRm 132 of the DB

	IV NEM	220 →							
Art.-Nr: 13697	UVP in €: 61,90								



Reisezugwagen 1. Klasse Apmz 121 der DB
1st class passenger coach Apmz 121 of the DB

NEU		220		
Art.-Nr: 13574	UVP in €: 48,90			



Reisezugwagen 1. Klasse Avmz 111 der DB
1st class passenger coach Avmz 111 of the DB

NEU		220		
Art.-Nr: 13584	UVP in €: 48,90			



Speisewagen WRmh 131 der DB
Dining car WRmh 131 of the DB

	220		
Art.-Nr: 16590	UVP in €: 61,90		



Aussichtswagen Adm 101 der DB
Dome car Adm 101 of the DB

NEU		220		
Art.-Nr: 16551	UVP in €: 65,50			



Reisezugwagen 1. Klasse Avmz 207 der DB
1st class passenger coach Avmz 207 of the DB

- „Eurofima“-Bauart in IC-Farbgebung/„Eurofima“ type in IC-colouring

Art.-Nr: 13530		UVP in €: 47,90		



Reisezugwagen 2. Klasse Bpmz 291 der DB
2nd class passenger coach Bpmz 291 of the DB

Art.-Nr: 16500		UVP in €: 47,90		



Reisezugwagen 1. Klasse Apmz der DB
1st class passenger coach Apmz of the DB

Art.-Nr: 16503		UVP in €: 47,90		



FORMNEUHEIT: Liegewagen 2. Klasse, Bcm 243, der DB
NEW: 2nd class couchette coach Bcm 243 of the DB

Art.-Nr: 16580		UVP in €: 52,50		



Reisezugwagen „Silberling“ 1./2. Klasse ABn 703 der DB
1st/2nd class passenger coach „Silberling“ ABn 703 of the DB

Art.-Nr: 13857		UVP in €: 41,50		



Reisezugwagen „Silberling“ 2. Klasse Bn 719 der DB
2nd class passenger coach „Silberling“ Bn 719 of the DB

Art.-Nr: 13856		UVP in €: 41,50		



Reisezugwagen „Silberling“ 2. Klasse, Bnrzb 728, der DB
2nd class passenger coach „Silberling“, Bnrzb 728, of the DB

- Wagen mit Steildach / with steep roof

Art.-Nr: 13863		UVP in €: 41,50		



Reisezugwagen 2. Klasse Bpmz 291 der DB
2nd class passenger coach Bpmz 291 of the DB

- Ergänzung zu den Sets 01655, 01691 und Einzelwagen 16507, zur Komplettierung des FD "Königssee" mit Kurswagen nach Zell am See / additional to sets 01655, 01691 and passenger coach 16507

	NEU				
Art.-Nr: 16506		UVP in €: 47,90			

Handmuster



Reisezugwagen 2. Klasse Bpmz 291 der DB, 2. Betriebsnummer
2nd class passenger coach Bpmz 291 of the DB, 2nd operation number

- Ergänzung zu den Sets 01655, 01691 und Einzelwagen 16506, zur Komplettierung des FD "Königssee" mit Kurswagen nach Zell am See / additional to sets 01655, 01691 and passenger coach 16506

	NEU				
Art.-Nr: 16507		UVP in €: 47,90			

Handmuster

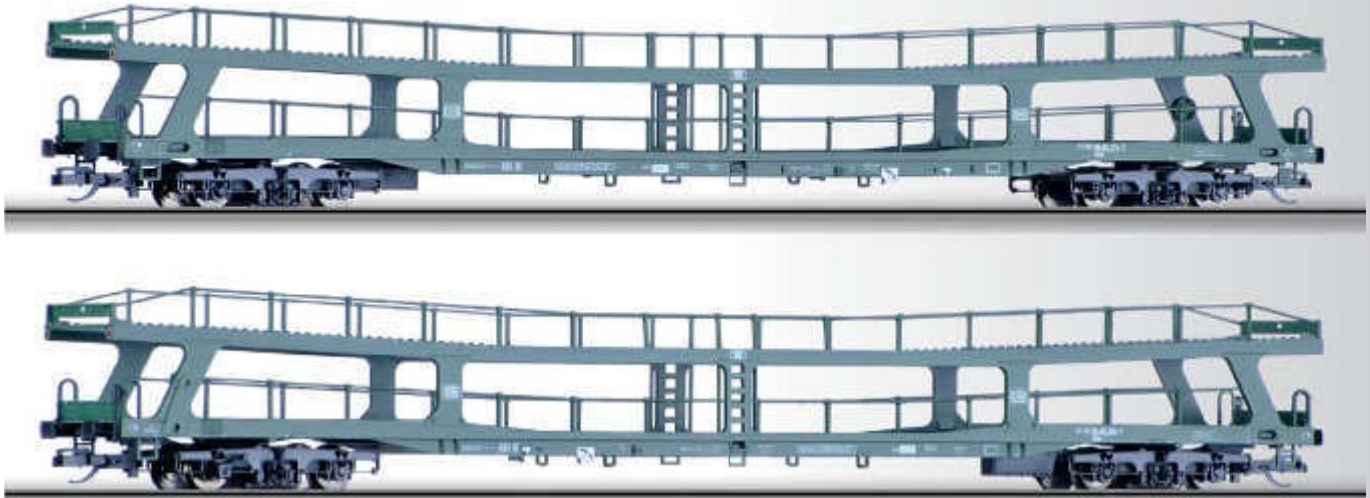

Wagenset der DB, bestehend aus zwei Autotransportwagen DDM 915
Set of the DB with two different cars DDM 915 for automobile transport

		442	
Art.-Nr: 01669	UVP in €: 84,50		



Kesselwagen „VTG“,
eingestellt bei der DB
Tank car „VTG“ of the DB

		76	
Art.-Nr: 14479 A	UVP in €: 26,90		



Kesselwagen „EVA“,
eingestellt bei der DB
Tank car „EVA“ of the DB

		92	
Art.-Nr: 14996 A	UVP in €: 35,90		



Kesselwagen „Valvoline“, einge-
stellt bei der DB
Tank car „Valvoline“ of the DB

NEU		74	
Art.-Nr: 95840	UVP in €: 30,90		



Handmuster

Niederbordwagen Kklmmo 493 der DB, beladen mit Matador Bus „Flower Power“

Low side car Kklmmo 493 of the DB with Matador bus „Flower Power“

- Endgültige Gestaltung stand bei Drucklegung noch nicht fest / Final design will be announced

NEU	IV NEM	76	■-□-□-□
Art.-Nr: 14924	UVP in €: 29,90		



Staubsilowagen Ucs 908 der DB

Silo car Ucs 908 of the DB

IV NEM	72	■-□-□-□
Art.-Nr: 17730	UVP in €: 33,50	



Staubsilowagen Ucs 908 „Quarzwerte“ der DB

Silo car Ucs 908 „Quarzwerte“ of the DB

IV NEM	72	■-□-□-□
Art.-Nr.: 17732 A	UVP in €: 33,50	



Staubsilowagen Ucs 908 „EVA“, eingestellt bei der DB

Silo car Ucs 908 "EVA" of the DB

NEU	IV NEM	72	■-□-□-□
Art.-Nr: 17734	UVP in €: 33,50		



Staubsilowagen Ucs 909 „Brandt“ der DB

Silo car Ucs 909 „Brandt“ of the DB

IV NEM	72	■-□-□-□
Art.-Nr.: 17761	UVP in €: 33,50	



Schwerlastwagen Sammp 705 der DB
Flat car Sammp 705 of the DB

- Abnehmbare Rungen / changeable stakes

	IV NEM	110	□	→	□	□	□
Art.-Nr: 15610	UVP in €: 37,90						



Taschenwagen mit Auflieger der DB
Pocket wagon of the DB with trailer

	IV NEM	138	□	→	□	□	□
Art.-Nr: 15568 A	UVP in €: 41,90						



Taschenwagen der DB mit zwei Wechselpritschen
Pocket wagon of the DB with load

	IV NEM	138	□	→	□	□	□
Art.-Nr: 18151	UVP in €: 41,90						



Taschenwagen Sdkms 707 der DB, beladen mit zwei 20' Containern
Pocket wagon Sdkms 707 of the DB with two 20' container

	NEU	IV NEM	138	□	→	□	□
Art.-Nr: 18152	UVP in €: 41,90						



Selbstentladewagen Fc 090
der DB
Hopper car Fc 090 of the DB

	IV NEM	81	■ → □	□ → ■	■ → □	□ → ■
Art.-Nr: 14585	UVP in €: 36,50					



Handmuster

FORMNEUHEIT:
Selbstentladewagen Fad 155
der DB
NEW: Hopper car Fad 155 of the
DB

NEU	IV NEM	83	■ → □	□ → ■	■ → □	□ → ■
Art.-Nr: 15170	UVP in €: 33,50					



Gedeckter Güterwagen Gbs 254
der DB
Box car Gbs 254 of the DB

NEU	IV NEM	117	■ → □	□ → ■	■ → □	□ → ■
Art.-Nr: 17162	UVP in €: 37,90					



Offener Güterwagen Es 040
der DB
Open car Es 040 of the DB

	IV NEM	76	■ → □	□ → ■	■ → □	□ → ■
Art.-Nr: 17243	UVP in €: 17,50					



Güterwagenset „Bananentransport“ der DB, bestehend aus drei Kühlwagen Ibbhpls 401
 Freight car set „banana transport“ of the DB, with three refrigerator cars Ibbhpls 401

	IV	355	■	→	←	□	■
	NEM		←	→		NEM	
Art.-Nr: 01630 A		UVP in €: 113,50					



Kühlwagen Ibbhs 396 der DB
 Refrigerator car Ibbhs 396 of the DB

	IV	117	■	→	←	□	■
	NEM		←	→		NEM	
Art.-Nr: 14691 A		UVP in €: 38,50					



Dieseltriebwagen BR 642 „Nationalparkbahn“ der DB AG

Rail car class 642 „Nationalparkbahn“ of the DB AG

- In Kooperation mit der ČD / In cooperation with the ČD



Dieseltriebwagen BR 642 „DB Regio Nordost“ der DB AG

Rail car class 642 „DB Regio Nordost“ of the DB AG



Diesellokomotive BR 229 der DB AG

Diesel locomotive class 229 of the DB AG

	V NEM1	162	☉	⊙	⊕	⊖	Flux12
Art.-Nr: 02791	UVP in €: 166,90						



Diesellokomotive BR 219 der DB AG

Diesel locomotive class 219 of the DB AG

- Formvariante mit geänderten Wartungskappen in den Seitenwänden / Changed version

NEU	V NEM1	162	☉	⊙	⊕	⊖	Flux12
Art.-Nr: 02792	UVP in €: 166,90						



NEU	VI NEM1	348	⊕ ⊖	⊕ ⊖	⊕ ⊖	⊕ ⊖	⊕ ⊖	⊕ ⊖	⊕ ⊖
Art.-Nr: 02881					UVP in €: 279,90				



NEU	VI NEM1	348	⊕ ⊖	⊕ ⊖	⊕ ⊖	⊕ ⊖	⊕ ⊖	⊕ ⊖	⊕ ⊖
Art.-Nr: 02882					UVP in €: 279,90				

Handmuster



Diesellokomotive BR 202 der DB AG, verkehrsrote Farbgebung
Diesel locomotive class 202 of the DB AG

V NEM1	116	⊕ ⊖	⊕ ⊖	⊕ ⊖	⊕ ⊖	⊕ ⊖	⊕ ⊖	⊕ ⊖	⊕ ⊖
Art.-Nr: 04588 A					UVP in €: 164,90				



Diesellokomotive BR 245 der DB AG
Diesel locomotive class 245 of the DB AG

VI NEM1	158	⊕ ⊖	⊕ ⊖	⊕ ⊖	⊕ ⊖	⊕ ⊖	⊕ ⊖	⊕ ⊖	⊕ ⊖
Art.-Nr: 04940					UVP in €: 158,50				

- Fernlicht schaltbar mit Decoder Art. 66023 /
main beam can be switched on by decoder item-no. 66023



Elektr locomotive BR 101 der DB AG
Electric locomotive class 101 of the DB AG

VI NEM	159				
Art.-Nr: 02314			UVP in €: 180,90		



Handmuster

Elektr locomotive BR 101 „Graubünden“ der DB AG
Electric locomotive class 101 „Graubünden“ of the DB AG

NEU	VI NEM	159			
Art.-Nr: 02315			UVP in €: 180,90		



Foto: TILLIG Werksarchiv

Elektr locomotive BR 143 der DB AG
Electric locomotive class 143 of the DB AG

NEU	VI NEM	139			
Art.-Nr: 02379			UVP in €: 178,90		



Elektr locomotive BR 140 der DB AG
 Electric locomotive class 140 of the DB AG

V NEM	135	☼	☼	☼	☼	☼	☼	☼	☼	☼	☼
Art.-Nr. 02390 A				UVP in €: 175,90							



Elektr locomotive BR 115, DB Autozug
 Electric locomotive class 115, DB Autozug

VI NEM	135	☼	☼	☼	☼	☼	☼	☼	☼	☼	☼
Art.-Nr.: 02391 A				UVP in €: 175,90							



Elektr locomotive BR 139 der DB AG
 Electric locomotive class 139 of the DB AG
 • Ausführung in orientroter Farbgebung

V NEM	135	☼	☼	☼	☼	☼	☼	☼	☼	☼	☼
Art.-Nr.: 02395				UVP in €: 175,90							



Elektrolokomotive BR 146.5 der DB AG in aktueller IC-Farbgebung
Electric locomotive class 146.5 of the DB AG in actual colouring

VI NEM	158				
Art.-Nr: 04909 A			UVP in €: 184,90		

- Fernlicht schaltbar mit Decoder Art. 66023 / Main beam can be switched on by decoder item-no. 66023



ICE 1-Set 2. Klasse der DB AG, bestehend aus zwei Triebköpfen
(davon ein Dummy) und einem 2. Klasse Reisezugwagen
2nd class ICE 1-set of the DB AG, with two traction units (one dummy)
and one 2nd class passenger coach

	570			Rmin 310	
Art.-Nr: 01353			UVP in €: 219,90		



Foto: Stefan Klein



ICE 1-Ergänzungsset 1 der DB AG, bestehend aus drei unterschiedlichen Reisezugwagen (1. Kl. Wagen, 2. Kl. Wagen, BordRestaurant)
 ICE 1-additional set 1 of the DB AG with three different passenger coaches (1st class passenger coach, 2nd class passenger coach and dining car)

	664	Rmin 310
Art.-Nr: 01611		UVP in €: 124,90



Set: 01611



ICE 1-Ergänzungswagen 1. Klasse der DB AG
 1st class passenger coach of the DB AG, additional to ICE 1

	220	Rmin 310
Art.-Nr: 13779		UVP in €: 41,50



ICE 1-Ergänzungsset 2 der DB AG, bestehend aus drei unterschiedlichen Reisezugwagen (1. Kl. Wagen, 2. Kl. Wagen, Servicewagen)
 ICE 1-additional set 2 of the DB AG with three different passenger coaches (1st class, 2nd class, service coach)

		664	Rmin 310
Art.-Nr: 01612	UVP in €: 121,50		



Set: 01612



ICE 1-Ergänzungswagen 2. Klasse der DB AG
 2nd class passenger coach of the DB AG, additional to ICE 1

		220	Rmin 310
Art.-Nr: 13780	UVP in €: 41,50		



Handmuster

Reisezugwagen set der DB AG, bestehend aus drei Reisezugwagen, Typ Y/B 70
 Passenger coach set of the DB AG with three passenger coaches, type Y/B 70

NEU	V NEM	616	E	NEM
Art.-Nr: 01699	UVP in €: 134,90			



Reisezugwagen 2. Klasse der DB AG
 2nd class passenger coach of the DB AG

	V NEM	155	E	NEM
Art.-Nr: 16620 A	UVP in €: 44,90			



Sitz-/Gepäckwagen 2. Klasse der DB AG
 2nd class baggage car of the DB AG

	V NEM	155	E	NEM
Art.-Nr: 16601 A	UVP in €: 48,90			



Reisezugwagen 1. Klasse, Aimz, der DB AG in InterRegio-Farbgebung
1st class passenger coach Aimz of the DB AG

V NEM	220 → ←	↳	□	→	□	↳	↳	↳
Art.-Nr: 13522			UVP in €: 47,90					



Reisezugwagen 2. Klasse, Bimz, der DB AG in InterRegio-Farbgebung
2nd class passenger coach Bimz of the DB AG

V NEM	220 → ←	↳	□	→	□	↳	↳	↳
Art.-Nr: 13523			UVP in €: 47,90					



Reisezugwagen 2. Klasse mit Fahrradabteil, BimdZ, der DB AG in InterRegio-Farbgebung
2nd class passenger coach with bicycle compartment BimdZ of the DB AG

V NEM	220 → ←	↳	□	→	□	↳	↳	↳
Art.-Nr: 13524			UVP in €: 47,90					



Reisezugwagen 1. Klasse mit Bord Bistro, ARkimbz, der DB AG in InterRegio-Farbgebung
1st class passenger coach ARkimbz of the DB AG

V NEM	220 → ←	↳	□	→	□	↳	↳	↳
Art.-Nr: 13525			UVP in €: 47,90					



Reisezugwagenset „Rollende Raststätte“ der DB AG, bestehend aus einem Autotransportwagen DDm 915 und einem Reisezugwagen 1. Klasse Avnz 111.2

Passenger coach set „Rollende Raststätte“ of the DB AG with one car DDm 915 for automobile transport and one 1st class passenger coach Avnz 111.2

NEU	V	442	■-□-□-□
	NEU	←-→	NEU
Art.-Nr: 01704		UVP in €: 90,50	

Foto: TILLIG Werksarchiv



Schlafwagen WLAB, Typ Y, der DB AG
Sleeping coach WLAB, type Y, of the DB AG

	V	204	⌚	■-□-□-□
	NEU	←-→	⌚	NEU
Art.-Nr: 16724		UVP in €: 54,50		



Doppelstock-Steuerwagen DBbzf 761.2 der DB AG
Double-deck driving cab coach DBbzf 761.2 of the DB AG

Am Steuer- kopfende		Am hinteren Wagenende	
VI NEM	227	VI NEM	Rmin 310
[Icons: 2 doors, 2 windows]		[Icons: 2 doors, 2 windows]	
Art.-Nr: 13802		UVP in €: 94,90	



Doppelstockwagen 1./2. Klasse DABz 755 der DB AG
1st/2nd class Double-deck coach DABz 755 of the DB AG

VI NEM	223	VI NEM	Rmin 310
[Icons: 2 doors, 2 windows]		[Icons: 2 doors, 2 windows]	
Art.-Nr: 13803		UVP in €: 54,50	



Doppelstockwagen 2. Klasse DBz 750 der DB AG
2nd class Double-deck coach DBz 750 of the DB AG

VI NEM	223	VI NEM	Rmin 310
[Icons: 2 doors, 2 windows]		[Icons: 2 doors, 2 windows]	
Art.-Nr: 13800		UVP in €: 54,50	



Reisezugwagen 2. Klasse, Bnrz 450, der DB AG
2nd class passenger coach Bnrz 450 of the DB AG

VI NEM	220	VI NEM	Rmin 310
[Icons: 2 doors, 2 windows]		[Icons: 2 doors, 2 windows]	
Art.-Nr: 13864		UVP in €: 41,50	



Reisezugwagen 2. Klasse „München Nürnberg Express“ der DB AG
2nd class passenger coach „München Nürnberg Express“ of the DB AG

- Ergänzung zu Set 01657 / Additional to set 01657

	VI NEM	220	☐	☐	☐	☐
Art.-Nr.: 16504 A	UVP in €: 47,90					



Reisezugwagenset „München Nürnberg Express 2“ der DB AG,
bestehend aus einem Reisezugwagen 1./2. Klasse und einem
Reisezugwagen 2. Klasse

Passenger coach set „München Nürnberg Express 2“ of the DB AG
with one 1st/2nd passenger coach and one 2nd class passenger coach

	VI NEM	442	☐	☐	☐	☐
Art.-Nr.: 01657 A	UVP in €: 92,90					



Foto: TILLIG Werksarchiv



Reisezugwagen 2. Klasse Bpmz 291 der DB AG
2nd class passenger coach Bpmz 291 DB AG

		V NEM	220			
Art.-Nr: 16501	UVP in €: 47,90					



Reisezugwagen 2. Klasse Bvmz 185 der DB AG
2nd class passenger coach Bvmz 185 of the DB AG

		V NEM	220			
Art.-Nr: 16533	UVP in €: 47,90					



Steuerwagen Bpmbdzf 297 der DB AG
Driving cab coach Bpmbdzf 297 of the DB AG

NEU		V NEM	220			
Art.-Nr: 13565	UVP in €: 82,90					



Reisezugwagen 1. Klasse Avmz 111.0 der DB AG
1st class passenger coach Avmz 111.0 of the DB AG

NEU		V NEM	220			
Art.-Nr: 13586	UVP in €: 48,90					

Handmuster



Reisezugwagen 1. Klasse Apmz 121.0 der DB AG
1st class passenger coach Apmz 121.0 of the DB AG

NEU		V NEM	220			
Art.-Nr: 16100	UVP in €: 48,90					

Handmuster



Liegewagen 2. Klasse Bvcmz 248 der DB AutoZug
2nd class couchette coach Bvcmz 248 of the DB AutoZug

NEU	V NEM	220 ← →	⌂	□ → □ NEM
Art.-Nr: 16582	UVP in €: 52,50			



Reisezugwagen mit BordBistro der DB AutoZug
Passenger coach with BordBistro of the DB AutoZug

NEU	V NEM	220 ← →	⌂	□ → □ NEM
Art.-Nr: 13528	UVP in €: 47,90			



Reisezugwagen 2. Klasse Bomdz 236.9 der DB-NachtZug
2nd class passenger coach Bomdz 236.9 of the DB-NachtZug

	⚡	V NEM	220 ← →	⌂	□ → □ NEM
Art.-Nr: 501279	UVP in €: 47,90				



Reisezugwagen 2. Klasse Bimdz 267.8 der DB NachtZug
2nd class passenger coach Bimdz 267.8 of the DB NachtZug

NEU	V NEM	220 ← →	⌂	□ → □ NEM
Art.-Nr: 501349	UVP in €: 47,90			



Steuerwagen Bpmbdzf 296.3 der DB AG
Driving cap coach Bpmbdzf 296.3 of the DB AG

- Steuerwagen in druckdichter Ausführung / cab car in pressure-tight version

Am Steuer-Kopfende		Am hinteren Wagenende	
VI	220	VI	220
NEM	NEM	NEM	NEM
Art.-Nr: 13564		UVP in €: 82,90	



Reisezugwagen 2. Klasse Bpmbkz 291.8 der DB AG „Snack Point“
2nd class passenger coach Bpmbkz 291.8 of the DB AG

VI		220	
NEM	NEM	NEM	NEM
Art.-Nr: 16505		UVP in €: 47,90	



Reisezugwagen 1. Klasse Apmz 121 der DB AG
1st class passenger coach Apmz 121 of the DB AG

V		220	
NEM	NEM	NEM	NEM
Art.-Nr: 13571		UVP in €: 47,90	



Reisezugwagen 1. Klasse Avmz 111 der DB AG
1st class passenger coach Avmz 111 of the DB AG

V		220	
NEM	NEM	NEM	NEM
Art.-Nr: 13576		UVP in €: 47,90	



Reisezugwagen 2. Klasse Bpmz 291 der DB AG
2nd class passenger coach Bpmz 291 of the DB AG

		V NEM	220		
Art.-Nr: 16502	UVP in €: 47,90				



Handmuster

Reisezugwagen 2. Klasse Bvmz 185 der DB AG
2nd class passenger coach Bvmz 185 of the DB AG

NEU		VI NEM	220		
Art.-Nr: 16535	UVP in €: 48,90				



Reisezugwagen 2. Klasse, Bvmz 111.2 der DB AG
2nd class passenger coach, Bvmz 111.2 of the DB AG

		V NEM	220		
Art.-Nr: 13581	UVP in €: 48,90				



Wagenset „DB Systemtechnik“ der DB AG, bestehend aus zwei Messbeiwagen
(1 x Bimz 259.8 Bauart Halberstadt, 1 x Bim 547.5 m-Wagen)
Passenger coach set „DB Systemtechnik“ of the DB AG
(1 x Bimz 259.8 type Halberstadt, 1 x Bim 547.5 type m-Wagen)

		VI NEM	442		
Art.-Nr.: 01686	UVP in €: 92,90				



Wagenset der DB AG, bestehend aus zwei Autotransportwagen DdM 916
Set of the DB AG with two different cars DdM 916 for automobile transport

		V	442		
		NEM		NEM	NEM
Art.-Nr: 01639 A	UVP in €: 84,50				



Wagenset der DB AG, bestehend aus drei Autotransportwagen DdM 916
Set of the DB AG with three different cars DdM 916 for automobile transport



Autotransportwagen DdM 915 der DB AG
Car DdM 915 of the DB AG for automobile transport

		V	220		
		NEM		NEM	NEM
Art.-Nr: 15051	UVP in €: 42,50				



Gedeckter Güterwagen
Gbs 254 der DB AG
Box car Gbs 254 of the DB AG

- Mit beweglichen Türen /
With moveable doors

		V	121		
		NEM		NEM	NEM
Art.-Nr: 17154 A	UVP in €: 38,50				



Wagenset der DB AG, bestehend aus zwei Autotransportwagen DDm 916
Set of the DB AG with two different cars DDm 916 for automobile transport

	V	442		
	NEM			NEM
Art.-Nr: 01640		UVP in €: 84,50		



	V	664		
	NEM			NEM
Art.-Nr: 01638 A		UVP in €: 124,90		



Gedeckter Güterwagen
Gbs 258 der DB AG
Box car Gbs 258 of the DB AG

- Mit beweglichen Türen /
With moveable doors

	V	117		
	NEM			NEM
Art.-Nr: 17158		UVP in €: 37,90		



Gedeckter Güterwagen
Gbs 263 der DB AG
Box car Gbs 263 of the DB AG

NEU	V	117		
	NEM			NEM
Art.-Nr: 17163		UVP in €: 37,90		



FORMNEUHEIT: Güterwagenset der DB AG, bestehend aus drei offenen Güterwagen Eaos-x 054
NEW: Freight car set of the DB AG with three differenz open cars Eaos-x 054

NEU	V	355	□	□	□
	NEM		□	□	NEM
Art.-Nr: 01677		UVP in €: 99,90			



FORMNEUHEIT: Offener Güterwagen Eaos-x 054 der DB AG
NEW: Open car Eaos-x 054 of the DB AG

NEU	V	117	□	□	□
	NEM		□	□	NEM
Art.-Nr: 15650		UVP in €: 33,50			



Standardhilfszug der DB AG, bestehend aus Energieversorgungs-, Geräte- und Aufenthaltswagen
 Standard maintenance train of the DB AG with three different cars



Handmuster

FORMNEUHEIT: Güterwagenset, bestehend aus drei offenen Güterwagen Eaos der On Rail GmbH, der DB und der BDZ

NEW: Freight car set with three different open cars Eaos (one On Rail GmbH, one DB, one BDZ)

NEU	V	355	□	□	□	□
	NEM	← →	← →	← →	← →	← →
Art.-Nr: 01678	UVP in €: 99,90					



Offener Güterwagen Eaos-x 075 der DB AG
Open car Eaos-x 075 of the DB AG

- Eine Tür pro Wagenseite/
One door per side

	V	117	□	□	□	□
	NEM	← →	← →	← →	← →	← →
Art.-Nr: 15247	UVP in €: 33,50					



V	413	□	□	□	□	□
NEM	← →	← →	← →	← →	← →	← →
Art.-Nr: 01626	UVP in €: 181,90					



Selbstentladewagen Fcs 092 der DB AG
Hopper car Fcs 092 of the DB AG

	VI NEM	81	■-□-□-□-□-□
Art.-Nr: 14588	UVP in €: 36,50		



Selbstentladewagen Fals der DB AG
High capacity hopper car Fals of the DB AG

	V NEM	108	■-□-□-□-□-□
Art.-Nr: 15281	UVP in €: 30,90		



Foto: E. Kermer



Selbstentladewagen Facs 124 der DB AG
Hopper car Facs 124 of the DB AG

	V NEM	159	■-□-□-□-□-□
Art.-Nr: 15371	UVP in €: 43,90		



Schwenkdachwagen Tadgs-y 958 „Getreide“ der DB AG
Swing roof car Tadgs-y 958 „Getreide“ of the DB AG

	V	159	■	□	□	□	□
	NEM	←	→	←	→	←	→
							NEM
Art.-Nr: 15351 A	UVP in €: 47,50						



Schwenkdachwagen Tads „SKW Piesteritz“ der DB AG
Swing roof car Tads „SKW Piesteritz“ of the DB AG

	V	159	■	□	□	□	□
	NEM	←	→	←	→	←	→
							NEM
Art.-Nr: 15352 A	UVP in €: 48,50						



Taschenwagen der DB AG, beladen mit zwei Wechselpritschen
Pocket wagon of the DB AG with load

	V	138	■	□	□	□	□
	NEM	←	→	←	→	←	→
							NEM
Art.-Nr.: 15569	UVP in €: 41,90						



Rungenwagen Rs-u 659 der DB AG, beladen mit Schienen
Stake car Rs-u 659 of the DB AG loaded with tracks

NEU	V	166	■	□	□	□	□
	NEM	←	→	←	→	←	→
							NEM
Art.-Nr: 18107	UVP in €: 39,90						



Doppeltragwagen Sdgggnos/Sdggmrs 739 / 744 „Kombiwaggon“ der DB AG
 Container car Sdgggnos/Sdggmrs 739/344 „Kombiwaggon“
 of the DB AG

	V	285	■	→	→	→	→	→	→
	NEM								NEM
Art.-Nr: 18001 A		UVP in €: 59,90							



Doppeltragwagen Sdgggnos/Sdggmrs 739/744 „Kombiwaggon“ der DB AG,
 beladen mit unterschiedlichen Containern
 Container car Sdgggnos/Sdggmrs 739/744 „Kombiwaggon“ of the DB AG loaded
 with different container

	NEU	V	285	■	→	→	→	→	→
		NEM							NEM
Art.-Nr: 18003		UVP in €: 73,90							

Handmuster



FORMNEUHEIT: Doppeltragwagen Sggmrs 715 „Kombiwaggon“, eingestellt bei
 der DB AG, beladen mit unterschiedlichen Containern
NEW: Container car Sggmrs 715 „Kombiwaggon“ of the DB AG loads with different
 container

	NEU	V	285	■	→	→	→	→	→
		NEM							NEM
Art.-Nr: 18030		UVP in €: 73,90							

Handmuster



Güterwagenset „VTG“, bestehend aus drei Staubsilowagen Ucs, eingestellt bei
 der DB AG / Freight car set „VTG“ with three different silo cars Ucs of the DB AG

	V	214	■	→	→	→	→	→	→
	NEM								NEM
Art.-Nr: 01635 A		UVP in €: 99,50							



Güterwagenset „Karsdorfer Zement / EVA“, eingestellt bei der DB AG,
bestehend aus drei Staubsilowagen Ucs 909
Freight car set „Karsdorfer Zement / EVA“ of the DB AG with three different
silo cars Ucs 909

NEU	V NEM	214 ← →	■ □ □ □ □ □ NEM
Art.-Nr: 01706		UVP in €: 99,50	



Handmuster

Staubsilowagen Ucs
„Karsdorfer Zement/EVA“,
eingestellt bei der DB AG
Silo car Ucs “Karsdorfer Zement/
EVA” of the DB AG

- Ergänzung zu Set 01706 / additional
to set 01706

NEU	V NEM	72 ← →	■ □ □ □ □ □ NEM
Art.-Nr: 17766		UVP in €: 33,50	



Staubsilowagen Ucs der KVG, ein-
gestellt bei der DB AG
Silo car Ucs KVG of the DB AG

NEU	V NEM	72 ← →	■ □ □ □ □ □ NEM
Art.-Nr: 17701		UVP in €: 33,50	



Handmuster

Staubsilowagen Ucs der DB AG
Silo car Ucs of the DB AG

NEU	V NEM	72 ← →	■ □ □ □ □ □ NEM
Art.-Nr: 17765		UVP in €: 33,50	

Tipp/Our Tip:

Einsatz der Privatbahn-Loks in Epoche VI: Diese Fahrzeuge werden für zahlreiche Transport-Dienstleistungen auf dem deutschen Schienennetz eingesetzt, insbesondere im Güterverkehr auch sehr oft mit Waggons der DB AG am „Haken“.

Use of the private railway locomotives: These tractive units are employed for numerous transportation services on the German rail network, especially in the carriage of goods sector and also very frequently with carriages of the DB AG on the „hook“.



Diesellokomotive T 334.0, Werklok des VEB Kombinat Schwarze Pumpe
Diesel locomotive class T 334.0 of the VEB Kombinat Schwarze Pumpe

NEU		80		
Art.-Nr: 04616	UVP in €: 93,90			



Diesellokomotive V60 D, Werklok VEB Leuna-Werke
Diesel locomotive V60 D of the VEB Leuna-Werke

	91			
Art.-Nr: 96114	UVP in €: 189,90			



Elektr.lokomotive Reihe 482 „INFRALEUNA“, eingestellt bei der SBB Cargo
Electric locomotive class 482 „INFRALEUNA“ of the SBB Cargo

VI	158					
Art.-Nr: 501323	UVP in €: 187,90					

- Fernlicht schaltbar mit Decoder Art. 66023 / Main beam can be switched on by decoder item-no. 66023
- Umsetzung des TRAXX2-Vorbildes auf Basis des vorhandenen TILLIG-Modells der TRAXX3 / Freelance model based on electric locomotive TRAXX3



Dieseltriebwagen BR 642 der Städtebahn Sachsen
Rail car class 642 of the Städtebahn Sachsen
• Taufname „Rose von Sebnitz 2.0“



Foto: TILLIG Werksarchiv

Dampflokomotive 52 8177-9,
Museumlok „Dampflokkfreunde
Berlin e.V.“
Steam locomotive 52 8177-9,
museum locomotive “Dampflokk-
freunde Berlin e.V.”

NEU	VI NEM	193	⊕ ⊖	Rmin 310	⊖ ⊕	⊖ ⊕	⊖ ⊕
Art.-Nr: 02289		UVP in €: 259,90					



Diesellokomotive BR 218 der MEG
Diesel locomotive class 218 of the MEG

NEU	VI NEM	137	⊕ ⊖	⊖ ⊕	⊖ ⊕	⊖ ⊕	⊖ ⊕
Art.-Nr: 02715		UVP in €: 166,90					



Diesellokomotive D20 der Bentheimer Eisenbahn AG
Diesel locomotive D20 of the Bentheimer Eisenbahn AG

NEU	VI NEM	152	⊕ ⊖	⊖ ⊕	⊖ ⊕	⊖ ⊕	⊖ ⊕
Art.-Nr: 04510		UVP in €: 166,90					



VI NEM	348	⊕ ⊖	⊖ ⊕	⊖ ⊕	⊖ ⊕
Art.-Nr: 02885 A		UVP in €: 289,90			



Foto: TILLIG Werksarchiv

Diesellokomotive V270.09 der Schienen-Güter-Logistik GmbH
Diesel locomotive V270.09 of the Schienen-Güter-Logistik GmbH

NEU	VI NEM	152																PluX12
Art.-Nr: 04511							UVP in €: 166,90											



Diesellok Reihe 285 der Express Rail (SK)
Diesel locomotive class 285 of the Express Rail (SK)

- Fernlicht schaltbar mit Decoder Art. 66023 / Main beam can be switched on by decoder item-no. 66023

	VI NEM	158																PluX12
Art.-Nr: 04934 A							UVP in €: 158,50											



Diesellokomotive BR 285 der RheinCargo GmbH
Diesel locomotive class 285 of the RheinCargo GmbH

- Fernlicht schaltbar mit Decoder Art. 66023 / Main beam can be switched on by decoder item-no. 66023

																			Handmuster
NEU	VI NEM	158																	PluX12
Art.-Nr: 04935							UVP in €: 158,50												



Diesellok MY 1149 der Altmark-Rail
Diesel locomotive MY 1149 of the Altmark-Rail

	VI NEM	158																	PluX12
Art.-Nr: 04536 A							UVP in €: 168,90												



Diesellokomotive V100 der SETG
Diesel locomotive V100 of the SETG

NEU	VI NEM	116	→	⊗	⊙	⊕	⊖	⊗	⊙	⊕	⊖	⊗	⊙	⊕	⊖
Art.-Nr: 04590		UVP in €: 164,90													



Diesellokomotive Reihe T 435 der KEG
Diesel locomotive class T 435 of the KEG

NEU	V NEM	105	→	⊗	⊙	⊕	⊖	⊗	⊙	⊕	⊖	⊗	⊙	⊕	⊖
Art.-Nr: 04629		UVP in €: 178,90													



Diesellokomotive BR 346 der DB AutoZug
Diesel locomotive class 346 of the DB AutoZug

NEU	VI NEM	91	→	⊗	⊙	⊕	⊖	⊗	⊙	⊕	⊖	⊗	⊙	⊕	⊖
Art.-Nr: 96154		UVP in €: 168,90													



Diesellokomotive BR 345 „CAPTRAIN“ der ITL
Diesel locomotive class 345 „CAPTRAIN“ of the ITL

NEU	VI NEM	91	→	⊗	⊙	⊕	⊖	⊗	⊙	⊕	⊖	⊗	⊙	⊕	⊖
Art.-Nr: 96155		UVP in €: 168,90													

Handmuster



Elektrolokomotive 110 043 „national express“ der PRESS
Electric locomotive 110 043 „national express“ of the PRESS

NEU	VI NEM	135	135	135	135	135	135	135	135	135
Art.-Nr: 02398		UVP in €: 175,90								



Foto: J. Lorenz

Elektrolokomotive BR 140 der EVB
Electric locomotive class 140 of the EVB

NEU	VI NEM	135	135	135	135	135	135	135	135	135
Art.-Nr: 02399		UVP in €: 175,90								



Elektrolokomotive 189 800 der Muldentail-Eisenbahnverkehrsgesellschaft mbH
Electric locomotive class 189 800 of the Muldentail-Eisenbahnverkehrsgesellschaft mbH

	VI NEM	162	162	162	162	162	162	162	162	162
Art.-Nr: 02478 A		UVP in €: 185,50								

- Fernlicht schaltbar mit Decoder Art. 66023 / Main beam can be switched on by decoder item-no. 66023



Elektrolokomotive BR 189 der MRCE
Electric locomotive class 189 of the MRCE

NEU	VI NEM	162	162	162	162	162	162	162	162	162
Art.-Nr: 02484		UVP in €: 185,50								

Handmuster

- Fernlicht schaltbar mit Decoder Art. 66023 / Main beam can be switched on by decoder item-no. 66023



Elektrolokomotive Reihe 186 der CAPTRAIN
Electric locomotive class 186 of the CAPTRAIN

- Fernlicht schaltbar mit Decoder Art. 66023 / Main beam can be switched on by decoder item-no. 66023

VI NEM1	158				
Art.-Nr: 04910 A			UVP in €: 184,90		



Elektrolokomotive Reihe 186 der RAILPOOL GmbH, vermietet an railCare AG (CH)
Electric locomotive class 186 RAILPOOL GmbH of the railCare AG (CH)

- Fernlicht schaltbar mit Decoder Art. 66023 / Main beam can be switched on by decoder item-no. 66023

VI NEM1	158				
Art.-Nr: 04911 A			UVP in €: 189,90		



Elektrolokomotive Reihe 186 der EURO CARGO RAIL
Electric locomotive class 186 of the EURO CARGO RAIL

- Fernlicht schaltbar mit Decoder Art. 66023 / Main beam can be switched on by decoder item-no. 66023

VI NEM1	158				
Art.-Nr: 04912			UVP in €: 184,90		



Elektrolokomotive Reihe 186 der RAILPOOL GmbH, vermietet an METRANS (CZ)
Electric locomotive class 186 RAILPOOL GmbH of the METRANS (CZ)

- Fernlicht schaltbar mit Decoder Art. 66023 / Main beam can be switched on by decoder item-no. 66023

VI NEM1	158				
Art.-Nr: 04915			UVP in €: 189,90		



Handmuster

Elektrolokomotive Reihe 183 der AWT
Electric locomotive class 183 of the AWT

NEU	VI NEM1	163				
Art.-Nr: 04964			UVP in €: 187,90			



Foto: TILLIG Werksarchiv

FORMNEUHEIT: Elektrolokomotive BR 156 der MEG
NEW: Electric locomotive class 156 of the MEG

NEU	VI NEM1	163				
Art.-Nr: 04991			UVP in €: 178,90			



Elektrolokomotive BR 142 der EGP
Electric locomotive class 142 of the EGP

NEU	VI NEM1	135				
Art.-Nr: 501350			UVP in €: 178,90			



Reisezugwagen 1./2. Klasse, ABvmdz, „alex“ der ARRIVA
1st/2nd class passenger coach Abvmdz „alex“ of the ARRIVA

	V NEM	VI NEM1	220		
Art.-Nr: 13582			UVP in €: 48,90		



Güterwagenset „Pressnitztalbahn“, bestehend aus zwei Selbstentladewagen Fcs
Freight car set „Pressnitztalbahn“ with two different hopper cars Fcs

	VI NEM	164	■	→	□	□	□	□
Art.-Nr: 01679	UVP in €: 71,50							



Selbstentladewagen Fcs der PRESS
Hopper car Fcs of the PRESS

NEU	VI NEM	81	■	→	□	□	□	□
Art.-Nr: 14589	UVP in €: 36,50							



Kesselwagen Zcs der VTG
Tank car Zcs of the VTG

	VI NEM	92	■	→	□	□	□	□
Art.-Nr: 14971 A	UVP in €: 36,50							



Kesselwagen der On Rail GmbH
Tank car of the On Rail GmbH

NEU	VI NEM	92	■	→	□	□	□	□
Art.-Nr: 14972	UVP in €: 36,50							

Handmuster



Kesselwagen Zces der NACCO
Tank car Zces of the NACCO

- Mit neuer Betriebsnummer /
with new car number

	VI NEM	92	■ → □	□ → □
Art.-Nr: 14995 A	UVP in €: 35,90			



Kesselwagen Zces der GATX
Tank car Zces of the GATX

	VI NEM	92	■ → □	□ → □
Art.-Nr: 14999	UVP in €: 35,90			



Kesselwagen Zacs der GATX
Tank car Zacs of the GATX

	VI NEM	120	■ → □	□ → □
Art.-Nr: 15469	UVP in €: 42,50			



Kesselwagen „HOYER“ der ERMEWA
Tank car „HOYER“ of the ERMEWA

	VI NEM	120	■ → □	□ → □
Art.-Nr: 15473	UVP in €: 42,50			



Schwenkdachwagen Tads der NACCO
Swing roof car Tads of the NACCO

NEU	VI NEM	159	■ → □	□ → ■
Art.-Nr: 15354	UVP in €: 47,50			



Staubbehälterwagen Uacs-y „cebe“ der ERWEMA
Silo car Uacs-y „cebe“ of the ERWEMA

	VI NEM	159	■ → □	□ → ■
Art.-Nr: 15492 A	UVP in €: 44,90			



Staubbehälterwagen Uacns „ENVILOC“ der ERMEWA
Silo car Uacns „ENVILOC“ of the ERMEWA

NEU	VI NEM	159	■ → □	□ → ■
Art.-Nr: 18251	UVP in €: 44,90			



Staubbehälterwagen Uacs „Josera“ der NACCO
Silo car Uacs „Josera“ of the NACCO

				Handmuster
NEU	VI NEM	159	■ → □	□ → ■
Art.-Nr: 18252	UVP in €: 44,90			

TIPP:

Regelmäßige TT-Sonderserien werden für die polnischen Modellbahnfreunde durch unseren Importeur in Polen (Firma AMC, Kontakt siehe S. 232) angeboten.

Regular TT special series are offered for the Polish model railway enthusiasts through our importer in Poland (AMC company, see page 232 for contact).



Dampflokomotive Reihe Ok1 der PKP
Steam locomotive class Ok1 of the PKP

- Ausführung mit großen PKP-Lampen / Version with lights type of the PKP

NEU		155	oo oo	Rmin	310	■-□-□-□-□	■-□-□-□-□	■-□-□-□-□	■-□-□-□-□
	NEM1	← →	↕			NEM	NEM	NEM	NEM
Art.-Nr: 02026					UVP in €: 289,90				



Dampflokomotive Reihe Ty 5 der PKP
Steam locomotive class Ty 5 of the PKP

		191	oo oo	Rmin	310	■-□-□-□-□	■-□-□-□-□	■-□-□-□-□	■-□-□-□-□
	NEM1	← →	↕			NEM	NEM	NEM	NEM
Art.-Nr: 02095 A					UVP in €: 259,90				



Güterwagenset „Militärtransport“, bestehend aus zwei Schwerlastwagen der PKP, beladen mit Panzer T34/85
Freight car set „military transport“ with two flat cars of the PKP, loaded with two tanks type T34/85

		222	■-□-□-□-□	■-□-□-□-□	■-□-□-□-□
	NEM1	← →	NEM	NEM	NEM
Art.-Nr: 01674			UVP in €: 107,90		



Offener Güterwagen Wddo (ex Breslau) der PKP
Open car Wddo (ex Breslau) of the PKP

		76	■-□-□-□-□	■-□-□-□-□
	NEM1	← →	NEM	NEM
Art.-Nr: 14277 A		UVP in €: 18,50		

Kühlwagen Slr der PKP
Refrigerator car Slr of the PKP

NEU		91	■-□-□-□-□	■-□-□-□-□
	NEM1	← →	NEM	NEM
Art.-Nr: 17003		UVP in €: 26,90		



Güterwagenset der PKP, bestehend aus sechs verschiedenen Güterwagen
Freight car set of the PKP with six different freight cars

	480	
Art.-Nr.: 01646	UVP in €: 104,90	



Schotterwagen Wddah der PKP
Hopper car Wddah of the PKP

NEU		58	
Art.-Nr: 17501			
UVP in €: 26,90			

Gedeckter Güterwagen Kdt
(ex Oppeln) der PKP
Box car Kdt (ex. Oppeln) of the PKP

	76	
Art.-Nr: 95212 A		
UVP in €: 28,50		



Kesselwagen Rh der PKP
Tank car of the PKP

	74	
Art.-Nr: 95834 A		
UVP in €: 29,90		



Schnellzugwagen 2. Klasse, Typ Y/B 70, der PKP
2nd class passenger coach, type Y/B 70, of the PKP

	204		
Art.-Nr: 16642	UVP in €: 44,90		



Schlafwagen WLAB, Typ Y, der PKP
Sleeping coach WLAB, type Y, of the PKP

	204		
Art.-Nr: 16722	UVP in €: 54,50		



Offener Güterwagen Es der PKP
Open car Es of the PKP

	76		
Art.-Nr: 17244	UVP in €: 17,50		



Gedeckter Güterwagen Gbs-x der PKP
Box car Gbs-x of the PKP

		117	
Art.-Nr: 17160	UVP in €: 37,90		



Handmuster

Diesellokomotive Reihe 650 der LOTOS Kolej
Diesel locomotive class 650 of the LOTOS Kolej

- Fernlicht schaltbar mit Decoder Art. 66023 / Main beam can be switched on by decoder item-no. 66023

NEU	VI NEM	158						PluX12
Art.-Nr: 04937					UVP in €: 158,50			



Handmuster

Elektr.lokomotive EU 45-846 der PKP Cargo
Electric locomotive class 45-846 of the PKP Cargo

- Fernlicht schaltbar mit Decoder Art. 66023 / Main beam can be switched on by decoder item-no. 66023

NEU	VI NEM	162						PluX12
Art.-Nr: 02486					UVP in €: 185,50			



Elektr.lokomotive Reihe 370 der PKP INTERCITY
Electric locomotive class 370 of the PKP INTERCITY

- Fernlicht schaltbar mit Decoder Art. 66023 / Main beam can be switched on by decoder item-no. 66023

	VI NEM	163						PluX12
Art.-Nr: 04953					UVP in €: 189,90			



Reisezugwagen 1. Klasse Admu der PKP INTERCITY
1st class passenger coach Admu of the PKP INTERCITY

		VI NEM	220					NEM
Art.-Nr: 13536					UVP in €: 49,90			

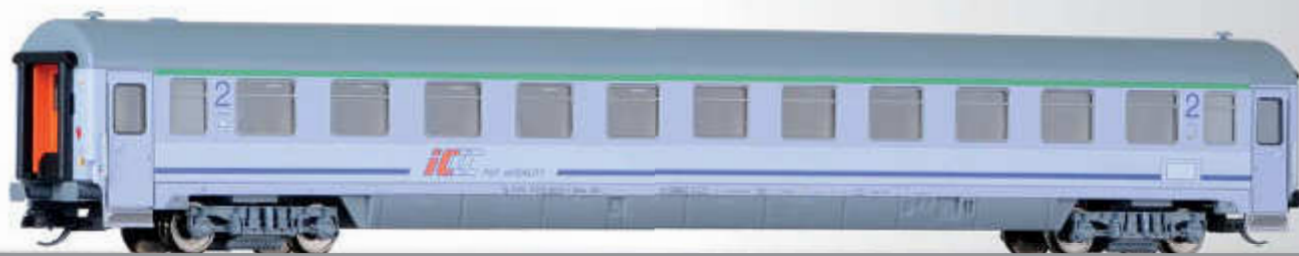

Reisezugwagen 2. Klasse Bdnmu der PKP INTERCITY
2nd class passenger coach Bdnmu of the PKP INTERCITY

		220		
Art.-Nr: 13553		UVP in €: 49,90		



Reisezugwagen 2. Klasse Typ Y/B 70 der PKP INTERCITY
2nd class passenger coach type Y/B 70 of the PKP INTERCITY

- mit geänderter Betriebsnummer / with different car number

		204		
Art.-Nr.: 16662		UVP in €: 45,90		



Schlafwagen WLAB, Typ Y, der PKP INTERCITY
Sleeping coach WLAB, type Y, of the PKP INTERCITY

		204		
Art.-Nr: 16727		UVP in €: 54,50		



Selbstentladewagen
Fals der PKP Cargo
High capacity hopper car
Fals of the PKP Cargo

		108		
Art.-Nr: 15280 A		UVP in €: 30,90		



Foto: A. Schulz / www.fotobahn.de

Rungenwagen Rs der PKP Cargo
Stake car RS of the PKP Cargo

NEU		166		
Art.-Nr: 18109		UVP in €: 30,90		

TIPP:

Regelmäßige TT-Sonderserien werden für die tschechischen Modellbahnfreunde durch unsere tschechische Auslandsvertretung (Firma DS Model, Kontakt siehe S. 232) angeboten.

Regular TT special series are offered for the Czech model railway enthusiasts through our importer in Czech Republic (DS Model company, see page 232 for contact).



Dampflokomotive Reihe 377.0 der ČSD
Steam locomotive class 377.0 of the ČSD

 NEM	166 ← →	oo oo ← →	Rmin 310	□-□ □-□ NEM NEM	●●●● NEM 662
Art.-Nr: 02024			UVP in €: 289,90		



Dampflokomotive Reihe 455.2 der ČSD
Steam locomotive class 455.2 of the ČSD

 NEM	113 ← →	oo oo ← →	Rmin 310	□-□ □-□ NEM NEM	●●●● NEM
Art.-Nr: 02180			UVP in €: 178,90		



Dampflokomotive Reihe 555.1 der ČSD
Steam locomotive class 555.1 of the ČSD

 NEM	191 ← →	oo oo ← →	Rmin 310	□-□ □-□ NEM NEM	●●●● NEM
Art.-Nr: 02299			UVP in €: 259,90		



Diesellokomotive
T 334 der ČSD
Diesel locomotive class
T 334 of the ČSD

		80	⊖ ⊕	●●●●●
	NEM	NEM	NEM	NEM
Art.-Nr: 04611 A	UVP in €: 93,90			



Diesellokomotive T 334.0 der
ČSD
Diesel locomotive class T 334.0
of the ČSD

NEU		80	⊖ ⊕	●●●●●
	NEM	NEM	NEM	NEM
Art.-Nr: 04615	UVP in €: 93,90			



Diesellokomotive T 435
der ČSD
Diesel locomotive class T 435
of the ČSD

		105	⊖ ⊕	⊖ ⊕	⊖ ⊕	●●●●●
	NEM	NEM	NEM	NEM	NEM	PluX12
Art.-Nr: 04621 A	UVP in €: 178,90					



Diesellokomotive T 334.0
der ČSD
Diesel locomotive T 334.0
of the ČSD

		77	⊖ ⊕	⊖ ⊕	⊖ ⊕	●●●●●
	NEM	NEM	NEM	NEM	NEM	NEM
Art.-Nr: 04635 A	UVP in €: 146,90					



Personenwagen 2. Klasse
(ex Bi-29) der ČSD
2nd class passenger coach
(ex Bi-29) of the ČSD

	116		
	NEM		NEM
Art.-Nr: 13009	UVP in €: 33,50		



Personenwagen 2. Klasse
(ex BCi-29) der ČSD
2nd class passenger coach
(ex BCi-29) of the ČSD

	116		
	NEM		NEM
Art.-Nr: 13018	UVP in €: 33,50		



Postwagen Post4-b/15
der ČSD
Mail waggon Post4-b/15
of the ČSD

	136		
	NEM		NEM
Art.-Nr: 13892	UVP in €: 48,90		



Güterwagenset „Militärtransport“, bestehend aus einem gedeckten Güterwagen Zr
(ex. OpeIn) und zwei Schwerlastwagen Px der ČSD, beladen mit Panzer T 34/85

- Panzer mit drehbarem Turm und beweglicher Kanone



Güterwagenset der ČSD, bestehend aus sechs verschiedenen Güterwagen



Offener Güterwagen Vtu
(ex. Breslau) der ČSD
Open car Vtu (ex. Breslau)
of the ČSD

	III NEM	76	■ → □	□ → ■
Art.-Nr: 14276	UVP in €: 18,50			



Niederbordwagen Np der ČSD
Low side car Np of the ČSD

	III NEM	76	■ → □	□ → ■
Art.-Nr: 14922	UVP in €: 17,50			



Schotterwagen St der ČSD
Hopper car St of the ČSD

NEU	III NEM	58	■ → □	□ → ■
Art.-Nr: 17502	UVP in €: 26,90			



Freight car set „military transport“ with one box car Zr (ex. Oppeln)
and two flat cars Px of the ČSD, loaded with two tanks type T 34/85

- Tank with turnable turret and moveable muzzle

	III NEM	260	■ → □	□ → ■
Art.-Nr: 01628 A	UVP in €: 134,90			



Freight car set of the ČSD with six different freight cars

	III NEM	480	■ → □	□ → ■
Art.-Nr: 01645	UVP in €: 104,90			



Säurekesselwagen R der ČSD
Acid tank car R of the ČSD

NEU		74	■-□-□-□
	NEM		NEM
Art.-Nr: 14982			
UVP in €: 29,90			



Kesselwagen Rf der ČSD
Tank car Rf of the ČSD

		76	■-□-□-□
	NEM		NEM
Art.-Nr: 17301			
UVP in €: 26,90			



FORMNEUHEIT: Gaskesselwagen Ra „PROPAN-BUTAN“ der ČSD, mit Sonnenschutzdach

NEW: Gas tank car Ra „PROPAN-BUTAN“ of the ČSD with sunshield

- Endgültige Gestaltung stand bei Drucklegung noch nicht fest / Final design will be announced

		120	■-□-□-□
	NEM		NEM
Art.-Nr: 15003		UVP in €: 44,90	

Handmuster



Gedeckter Güterwagen Z der ČSD
Box car Z of the ČSD

		76	■-□-□-□
	NEM		NEM
Art.-Nr: 17133			
UVP in €: 24,90			



Gedeckter Güterwagen Z der ČSD
Box car Z fo the ČSD

NEU		83	■-□-□-□
	NEM		NEM
Art.-Nr: 17137			
UVP in €: 24,90			

Handmuster



Gedeckter Güterwagen Zr (ex. Oppeln) der ČSD / Box car Zr (ex. Oppeln) of the ČSD

		76	■-□-□-□
	NEM		NEM
Art.-Nr: 95211 A		UVP in €: 28,50	



Diesellokomotive T 334 der ČSD
Diesel locomotive T 334 der ČSD

	IV NEM	80	→	•••••	NEM
Art.-Nr: 04614	UVP in €: 93,90				



Diesellok Reihe T 435 der ČSD
Diesel locomotive class T 435 of the ČSD

- Ausführung mit Schwanenhals-Drehgestellen

	IV NEM	105	↔	•••••	PluX12
Art.-Nr: 04627	UVP in €: 178,90				



Sitz-/Gepäckwagen 2. Klasse, Typ Y/B 70, der ČSD
2nd class passenger coach with baggage compartment, type Y/B 70, of the ČSD

	IV NEM	204	↔	•••••	NEM
Art.-Nr: 16697	UVP in €: 49,90				



Liegewagen 2. Klasse, Typ Y, der ČSD
2nd class couchette coach, type Y, of the ČSD

	IV NEM	204	↔	•••••	NEM
Art.-Nr: 16651	UVP in €: 44,90				



Reisezugwagen 1. Klasse, Typ Y, der ČSD
1st class passenger coach, type Y, of the ČSD

Art.-Nr: 16647		UVP in €: 44,90			



Reisezugwagen 1./2. Klasse, Typ Y, der ČSD
1st/2nd class passenger coach, type Y, of the ČSD

Art.-Nr: 16643		UVP in €: 44,90			



Reisezugwagen 2. Klasse, Typ Y, der ČSD
2nd class passenger coach, type Y, of the ČSD

Art.-Nr: 16640		UVP in €: 44,90			



Weitstreckenschlafwagen WLABmv, Typ Y, der ČSD
Sleeping coach WLABmv, type Y, of the ČSD

Art.-Nr: 16701		UVP in €: 51,50			



Gedeckter Güterwagen Gbs
der ČSD

Box car Gbs of the ČSD

- Mit beweglichen Laderaumtüren /
With moveable doors

	IV NEM	117 ← →	■ □ □ □ □ □ NEM
Art.-Nr: 17151	UVP in €: 37,90		



Kühlwagen Ibbhq der ČSD

Tank car Ibbhq of the ČSD

	IV NEM	117 ← →	■ □ □ □ □ □ NEM
Art.-Nr: 14695	UVP in €: 38,50		



Offener Güterwagen Eas der ČSD

Open car Eas of the ČSD

	IV NEM	117 ← →	■ □ □ □ □ □ NEM
Art.-Nr: 15250	UVP in €: 33,50		



Gedeckter Güterwagen Gklm /
Zr der ČSD

Box car Gklm / Zr of the ČSD

	IV NEM	76 ← →	■ □ □ □ □ □ NEM
Art.-Nr: 95214	UVP in €: 28,50		



Schlafwagen WLAB, Typ Y, der ČD
Sleeping coach WLAB, type Y, of the ČD

		V	204			
		NEM				
Art.-Nr. 16725	UVP in €: 54,50					



Liegewagen 2. Klasse, Typ Y/B 70, der ČD
2nd class couchette coach, type Y/B 70, of the ČD

NEU		V	204			
		NEM				
Art.-Nr. 16667	UVP in €: 45,90					



Reisezugwagen 1./2. Klasse, Typ Y/B 70, der ČD
1st/2nd class passenger coach, type Y/B 70, of the ČD

		V	204			
		NEM				
Art.-Nr. 16653	UVP in €: 45,90					



Foto: J. Foelke



Reisezugwagen 2. Klasse, Typ Y/B 70, der ČD
2nd class passenger coach, type Y/B 70, of the ČD

		V	204			
		NEM				NEM
Art.-Nr: 16656		UVP in €: 45,90				



Reisezugwagen 2. Klasse, Typ Y/B 70, mit Fahrradabteil der ČD
2nd class passenger coach with bicycle compartment, type Y/B 70, of the ČD

NEU		V	204			
		NEM				NEM
Art.-Nr: 16668		UVP in €: 45,90				

Handmuster



Gedeckter Güterwagen Gbqs der ČD
Box car Gbqs of the ČD

		V	117			
		NEM				NEM
Art.-Nr: 17159		UVP in €: 37,90				



Niederbordwagen Res der ČD
Low side car Res of the ČD

		V	166			
		NEM				NEM
Art.-Nr: 15571		UVP in €: 28,50				



Reisezugwagen 1. Klasse, Typ Y/B 70, der ČD
1st class passenger coach, type Y/B 70, of the ČD

		VI	204			
		NEM				NEM
Art.-Nr: 16645			UVP in €: 45,90			



Reisezugwagen 1./2. Klasse, Typ Y/B 70, der ČD
1st/2nd class passenger coach, type Y/B 70, of the ČD

		VI	204			
		NEM				NEM
Art.-Nr: 16657			UVP in €: 45,90			



Reisezugwagen 2. Klasse, Typ Y/B 70, der ČD
2nd class passenger coach, type Y/B 70, of the ČD

		VI	204			
		NEM				NEM
Art.-Nr: 16646			UVP in €: 45,90			



Liegewagen 2. Klasse, Typ Y/B 70, der ČD
2nd class couchette coach type Y/B 70 of the ČD

		VI	204			
		NEM				NEM
Art.-Nr: 16663			UVP in €: 45,90			



Reisezugwagen 2. Klasse, Typ Y/B 70 mit Fahrradabteil, der ČD
2nd class passenger coach with bicycle compartment type Y/B 70 of the ČD

		VI	204			
		NEM				NEM
Art.-Nr: 16664			UVP in €: 45,90			



Reisezugwagen 1. Klasse Amz der ČD
1st class passenger coach Amz of the ČD

- Für den Einsatz im EuroCity-Verkehr, passend zu Rh 1216 der ÖBB (04952) und BR 101 DB AG (02314, 02315) / For EuroCity trains

		V	VI	220			
		NEM	NEM				NEM
Art.-Nr: 16520 A		UVP in €: 47,90					



Reisezugwagen 2. Klasse Bmz der ČD
2nd class passenger coach Bmz of the ČD

- Für den Einsatz im EuroCity-Verkehr, passend zu Rh 1216 der ÖBB (04952) und BR 101 DB AG (02314, 02315) / For EuroCity trains

		V	VI	220			
		NEM	NEM				NEM
Art.-Nr: 16530 A		UVP in €: 47,90					



Reisezugwagen 2. Klasse, Bmz der ČD mit „e-tiket“-Aufschrift
2nd class passenger coach Bmz „e-ticket“ of the ČD

		VI	220				
		NEM					NEM
Art.-Nr: 16532 A		UVP in €: 48,90					



Sitz-/Gepäckwagen 2. Klasse, Typ Y/B 70, der ČD
2nd class passenger coach with baggage compartment, type Y/B 70, of the ČD

		VI	204				
		NEM					NEM
Art.-Nr: 16695		UVP in €: 49,90					



Handmuster

Weitstreckenschlafwagen „S nami PO EVROPE“, Typ Y, der ČD
 Sleeping coach „S nami PO EVROPE“, type Y, of the ČD

NEU		204	
Art.-Nr: 16705	UVP in €: 54,50		



Schlafwagen WLAB, Typ Y, der ČD
 Sleeping coach WLAB type Y of the ČD

	204	
Art.-Nr: 16728	UVP in €: 54,50	



Foto: TILLIG Werksarchiv



Wagenset der ČD, bestehend aus zwei Autotransportwagen DDm
Set with two different cars DDm of the ČD for automobile transport

		442	
	NEM		NEM
Art.-Nr: 01641 A		UVP in €: 84,50	



Wagenset der ČD, bestehend aus zwei Autotransportwagen DDm 915
Set of the ČD with two different cars DDm 915 for automobile transport

		442	
	NEM		NEM
Art.-Nr: 01670		UVP in €: 84,50	



Güterwagenset der ČD Cargo, bestehend aus drei offenen
Güterwagen Es
Freight car set of the ČD Cargo with three open cars Es

NEU		253	
	NEM		NEM
Art.-Nr: 01716		UVP in €: 50,50	



Schwenkdachwagen Tdgn's der
ČD Cargo
Swing roof car Tdgn's of the ČD
Cargo

	VI NEM	81	■	→	←	□	□	□	□
Art.-Nr: 14577	UVP in €: 36,50								



Kühlwagen Ibbhs der ČD Cargo
Refrigerator car Ibbhs of the ČD
Cargo

	VI NEM	117	■	→	←	□	□	□	□
Art.-Nr: 14693 A	UVP in €: 38,50								



Selbstentladewagen Falls
der ČD Cargo
High capacity hopper car Falls of
the ČD Cargo

	VI NEM	108	■	→	←	□	□	□	□
Art.-Nr: 15298	UVP in €: 30,90								



Kesselwagen Zaes der ČD Cargo
Tank car Zaes of the ČD Cargo

	VI NEM	120	■	→	←	□	□	□	□
Art.-Nr: 15471	UVP in €: 42,50								



Kesselwagen Zas der RYKO PLUS s.r.o.
Tank car Zas of the RYKO PLUS s.r.o.

Handmuster

NEU	VI	120	■	□	□	□	□
	NEM	←	→	←	→	←	→
Art.-Nr:15480		UVP in €: 42,50					



Staubbehälterwagen Uacns „Lhoist“, eingestellt bei der ČD
Silo car Uacns „Lhoist“ of the ČD

	VI	159	■	□	□	□	□
	NEM	←	→	←	→	←	→
Art.-Nr: 15494 A		UVP in €: 44,90					

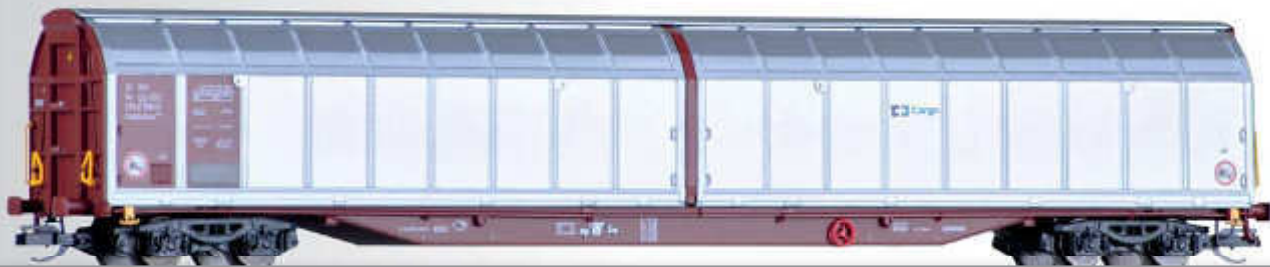

Schiebewandwagen Habbillns der ČD Cargo
Sliding cover box car Habbillns of the ČD Cargo

	VI	194	■	□	□	□	□
	NEM	←	→	←	→	←	→
Art.-Nr: 15804		UVP in €: 41,90					



Offener Güterwagen Es der ČD
Open car Es of the ČD

NEU	VI	83	■	□	□	□	□
	NEM	←	→	←	→	←	→
Art.-Nr: 17253		UVP in €: 17,50					

Handmuster



Reisezugwagen 1./2. Klasse, Typ Y/B 70, der ZSSK
1st/2nd class passenger coach, type Y/B 70, of the ZSSK

		204			
Art.-Nr: 16658		UVP in €: 45,90			



Reisezugwagen 2. Klasse, Typ Y/B 70, der ZSSK
2nd class passenger coach, type Y/B 70, of the ZSSK

		204			
Art.-Nr: 16659		UVP in €: 45,90			



Sitz-/Gepäckwagen 2. Klasse, Typ Y/B 70, der ZSSK
2nd class passenger coach with baggage compartment, type Y/B 70, of the ZSSK

			204				Handmuster
NEU							
Art.-Nr: 16698		UVP in €: 49,90					



Weitstreckenschlafwagen WLAB, Typ Y, der ZSSK
Sleeping coach WLAB, type Y, of the ZSSK

		204			
Art.-Nr: 16704		UVP in €: 54,50			



Schlafwagen WLAB, Typ Y, der ZSSK
Sleeping coach WLAB type Y of the ZSSK

		204			
Art.-Nr: 16729		UVP in €: 54,50			



Wagenset der ZSSK, bestehend aus zwei Autotransportwagen DDm 916
Set of the ZSSK with two different cars DDm 916 for automobile transport

	VI	442	■-□-□-□
	NEM		NEM
Art.-Nr: 01668		UVP in €: 84,50	



Offener Güterwagen Eaos der AWT
Open car Eaos of the AWT

NEU	VI	117	■-□-□-□
	NEM		NEM
Art.-Nr: 15260		UVP in €: 33,50	



Schiebewandwagen Habbillns der ZSSK Cargo
Sliding cover box car Habbillns of the ZSSK Cargo

Handmuster

NEU	VI	194	■-□-□-□
	NEM		NEM
Art.-Nr: 15806		UVP in €: 41,90	



Niederbordwagen Res der ZSSK
Low side car Res of the ZSSK

Handmuster

NEU	VI	166	■-□-□-□
	NEM		NEM
Art.-Nr: 18110		UVP in €: 30,90	



Schwenkdachwagen Tds der EEWS
Swing roof car Rds of the EEWS

	VI	81	■-□-□-□
	NEM		NEM
Art.-Nr: 14578		UVP in €: 36,50	



Diesellokomotive Reihe ChME2 der SZD
Diesel locomotive class ChME2 of the SZD

	IV NEM1	105	→	→	→	→	→	→	→	→	→
Art.-Nr. 04628	UVP in €: 178,90										



Weitstreckenschlafwagen WLABm, Typ Y, der SZD
Sleeping car WLABm (type Y) of the SZD

	IV NEM1	204	→	→	→	→	→	→	→	→	→
Art.-Nr. 16700	UVP in €: 51,50										



Foto: TILLIG Werksarchiv



Weitstreckenschlafwagen WLABme, Typ Y, der RZD
Sleeping coach WLABme, type Y, of the RZD

	VI NEM1	204	→	→	→	→	→	→	→	→	→
Art.-Nr. 16703	UVP in €: 54,50										



Dampflokomotive Rh 52 der ÖBB
Steam locomotive Rh 52 of the ÖBB

	193			
Art.-Nr: 02285		UVP in €: 259,90		



Elektr locomotive 1118.01 der ÖBB
Electric locomotive 1118.01 of the ÖBB

	141			
Art.-Nr: 02452 A		UVP in €: 178,90		



Reisezugwagen-Set der ÖBB, bestehend aus drei Schürzenwagen
(1./2. Klasse, 2. Klasse und 2. Klasse/Buffer)
Passenger coach set of the ÖBB with three different passenger coaches
(1st/2nd class, 2nd class and 2nd class/buffet car)

	554			
Art.-Nr: 01596 A		UVP in €: 156,90		



Personenwagen 1./2. Klasse ABiph (ex Bi-29) der ÖBB
1st/2nd class passenger coach ABiph (ex Bi-29) of the ÖBB

	III NEM	116 ← →	E	□ → □ □ □ □ NEM
Art.-Nr: 13004	UVP in €: 33,50			



Personenwagen 2. Klasse, Biph (ex Bi-29) der ÖBB
2nd class passenger coach Biph (ex Bi-29) of the ÖBB

	III NEM	116 ← →	E	□ → □ □ □ □ NEM
Art.-Nr: 13008	UVP in €: 33,50			



Personenwagen 2. Klasse, Bih (ex BCi-29) der ÖBB
2nd class passenger coach Bih (ex BCi-29) of the ÖBB

	III NEM	116 ← →	E	□ → □ □ □ □ NEM
Art.-Nr: 13017	UVP in €: 33,50			



Gepäckwagen Pwi der ÖBB
Baggage waggon Pwi of the ÖBB

	III NEM	116 ← →	□ → □ □ □ □ NEM
Art.-Nr: 13417 A	UVP in €: 28,90		



Packwagen Pw3 der ÖBB
Baggage car Pw3 of the ÖBB

NEU	III NEM	110 ← →	□ → □ □ □ □ NEM
Art.-Nr: 13456	UVP in €: 28,90		

Handmuster



Güterzugbegleitwagen
(ex Pwgs 41) der ÖBB
Baggage car (ex Pwgs 41)
of the ÖBB

	III NEM	86	■-□-□-□
Art.-Nr: 13475	UVP in €: 31,50		



Offener Güterwagen Om der ÖBB
Open car Om of the ÖBB

	III NEM	76	■-□-□-□
Art.-Nr: 14278	UVP in €: 18,50		



Kühlwagen Tdhs der ÖBB
Refrigerator car Tdhs of the ÖBB

NEU	III NEM	91	■-□-□-□
Art.-Nr: 17004	UVP in €: 26,90		



Kesselwagen der ÖMV, eingestellt
bei den ÖBB
Tank car ÖMV of the ÖBB

	III-IV NEM	76	■-□-□-□
Art.-Nr: 17300	UVP in €: 26,90		



Gedeckter Güterwagen Gms
der ÖBB
Box car Gms of the ÖBB

	III NEM	76	■-□-□-□
Art.-Nr: 95213	UVP in €: 28,50		



Reisezugwagen 1. Klasse Amoz der ÖBB
1st class passenger coach Amoz of the ÖBB

NEU		220	
Art.-Nr: 13541	UVP in €: 47,90		



Reisezugwagen 2. Klasse, Bomz, der ÖBB
2nd class passenger coach Bomz of the ÖBB

	220	
Art.-Nr: 13558	UVP in €: 47,90	



Wagenset der ÖBB, bestehend aus zwei Autotransportwagen DDm
Set of the ÖBB with two cars DDm for automobile transport

NEU		442	
Art.-Nr: 01702	UVP in €: 84,50		



Staubsilowagen Ucs der ÖBB
Silo car Ucs of the ÖBB

	72	
Art.-Nr: 17733	UVP in €: 33,50	



Doppeltragwagen Sdgggnos/Sdggmrs 739 / 744 „Ökombi“, der ÖBB
Container car Sdgggnos/Sdggmrs 739/344 of the ÖBB

	V NEM	285	■ → □ ←	□ □ □ □
Art.-Nr: 18002 A	UVP in €: 59,90			



Handmuster

Doppeltragwagen Sdgggnos/Sdggmrs 739/744 „Ökombi“ der ÖBB, beladen mit unterschiedlichen Containern
Container car Sdgggnos/Sdggmrs 739/744 „Ökombi“ of the ÖBB loaded with different container

NEU	V NEM	285	■ → □ ←	□ □ □ □
Art.-Nr: 18004	UVP in €:73,90			



Handmuster

Staubbehälterwagen Uacs „TRANSCEREALES/C.T.C.“, eingestellt bei den ÖBB
Silo car Uacs "TRANSCEREALES/C.T.C" of the ÖBB

NEU	IV NEM	159	■ → □ ←	□ □ □ □
Art.-Nr: 18250	UVP in €: 44,90			



Elektrolokomotive Rh 1216 der ÖBB
Electric locomotive Rh 1216 of the ÖBB

- Fernlicht schaltbar mit Decoder Art. 66023 / Main beam can be switched on by decoder item-no. 66023

VI NEM	163	⊕ ⊖	□ □ □ □	● ● ● ● ● ● ● ●
Art.-Nr: 04952	UVP in €: 187,90			



Reisezugwagen 1. Klasse Amz der ÖBB
1st class passenger coach Amz of the ÖBB

		220		
Art.-Nr: 13535	UVP in €: 48,90			



Reisezugwagen 2. Klasse Bmz der ÖBB
2nd class passenger coach Bmz of the ÖBB

			220		
Art.-Nr: 13550	UVP in €: 47,90				

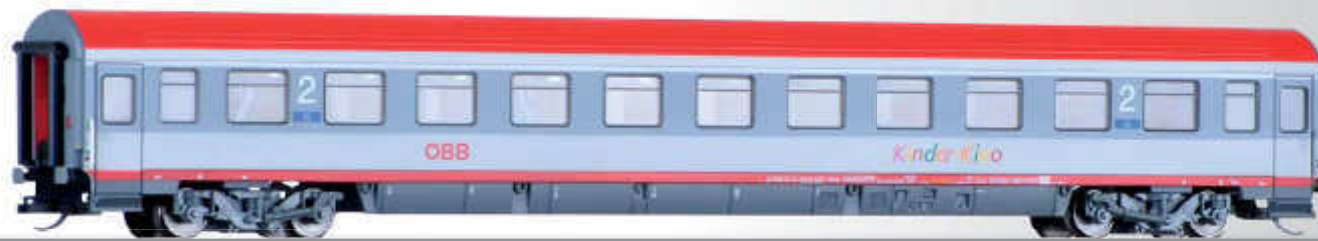

Reisezugwagen 2. Klasse Bmz „Kinder-Kino“, der ÖBB
2nd class passenger coach Bmz „Kinder-Kino“ of the ÖBB

		220		
Art.-Nr: 13555	UVP in €: 47,90			



Reisezugwagen 2. Klasse Bmz der ÖBB
2nd class passenger coach Bmz of the ÖBB

			220		
Art.-Nr: 16531	UVP in €: 47,90				



Schwenkdachwagen Tds „Austria Glas Recycling“ der ÖBB
Swing roof car „Austria Glas Recycling“ of the ÖBB

	VI NEM	81	□-□-□-□	□-□-□-□
Art.-Nr: 14575 A	UVP in €: 36,50			



Offener Güterwagen Eas der ÖBB
Open car Eas of the ÖBB

	VI NEM	117	□-□-□-□	□-□-□-□
Art.-Nr: 15248	UVP in €: 33,50			



Rungenwagen Rs der ÖBB, beladen mit Schienen
Stake car Rs of the ÖBB loaded with tracks

NEU	VI NEM	166	□-□-□-□	□-□-□-□
Art.-Nr: 18108	UVP in €: 39,90			



Elektrolokomotive 1216 960 der Steiermarkbahn
Electric locomotive 1216 960 of the Steiermarkbahn

- Fernlicht schaltbar mit Decoder Art. 66023 / Main beam can be switched on by decoder item-no. 66023

	VI NEM	163	⊗	⊗	⊗	⊗	□-□-□-□	□-□-□-□
Art.-Nr: 04956 A	UVP in €: 187,90							



Staubbehälterwagen Uacs „Lenzing“ der VTG
Silo car Uacs „Lenzing“ of the VTG

	VI NEM	159	□-□-□-□	□-□-□-□
Art.-Nr: 15491	UVP in €: 44,90			



Weinfasswagen R der MAV
Wine barrel car R of the MAV

NEU	III NEM	76 ← →	■ □ ⊞ ⊞ NEM
Art.-Nr: 14437	UVP in €: 26,90		



Offener Güterwagen Ky der MAV
Open car Ky of the MAV

NEU	III NEM	83 ← →	■ □ ⊞ ⊞ NEM
Art.-Nr: 17250	UVP in €: 17,50		



Diesellokomotive M61 der MAV
Diesel locomotive class M61 of the MAV

IV NEM	158 ← →	⊞ ⊞ ⊞ ⊞ Flux12
Art.-Nr: 04535	UVP in €: 168,90	

Diesellokomotive Reihe M61 der MAV - mit Sound
Diesel locomotive class M61 of the MAV - with sound

NEU	IV NEM	158 ← →	⊞ ⊞ ⊞ ⊞ Flux12
Art.-Nr: 92654	UVP in €: 329,90		



Schlafwagen WLAB, Typ Y, der MAV
Sleeping car WLAB, type Y, of the MAV

III NEM	IV NEM	204 ← →	⊞ ⊞ ⊞ ⊞ Flux12
Art.-Nr: 16721	UVP in €: 51,50		



Reisezugwagen 1. Klasse, Typ Y/B 70, der MAV
1st class passenger coach type Y/B 70 of the MAV

	204		
Art.-Nr.: 16665		UVP in €: 45,90	



Reisezugwagen 2. Klasse, Typ Y/B 70, der MAV
2nd class passenger coach, type Y/B 70, of the MAV

	204		
Art.-Nr.: 16641		UVP in €: 45,90	



Offener Güterwagen Eaos
der MAV
Open car Eaos of the MAV

	117	
Art.-Nr.: 15256		UVP in €: 33,50



Gedeckter Güterwagen Gbgs
der MAV
Box car Gbgs of the MAV

	117	
Art.-Nr.: 17152		UVP in €: 37,90



Elektrolokomotive Reihe 480 der MAV
Electric locomotive class 480 of the MAV

- Fernlicht schaltbar mit Decoder Art. 66023 / Main beam can be switched on by decoder item-no. 66023

VI NEM	158									Plus12
Art.-Nr: 04908					UVP in €: 184,90					



Reisezugwagenset der MAV-Start, bestehend aus zwei Reisezugwagen Bauart Halberstadt (1./2. Klasse (AByee) und 2. Klasse (Bydee) in aktueller Lackierung)
Passenger coach set of the MAV-Start, type Halberstadt (one 1st/2nd class (AByee) and one 2nd class (Bydee) in actual colouring)

VI NEM	442									
Art.-Nr: 01625					UVP in €: 92,90					



Reisezugwagen 2. Klasse By der MAV-Start
2nd class passenger coach By of the MAV-Start

VI NEM	220									
Art.-Nr: 13592					UVP in €: 45,90					



Schlafwagen WLAB, Typ Y, der MAV
Sleeping coach WLAB, type Y, of the MAV

	V NEM	VI NEM	204							
Art.-Nr: 16726					UVP in €: 54,50					



Niederbordwagen Res der MAV
Low side car Res of the MAV

	V	166	■	□	□	□	□
	NEM		→				NEM
Art.-Nr: 18105	UVP in €: 30,90						



Offener Güterwagen Eas der MAV-CARGO
Open car Eas of the MAV-CARGO

							Handmuster
	NEU	VI	117	■	□	□	□
		NEM		→			NEM
Art.-Nr: 15262	UVP in €: 33,50						



Selbstentladewagen Fals der MAV Cargo
Hopper car Fals of the MAV Cargo

		VI	108	■	□	□	□
		NEM		→			NEM
Art.-Nr: 15300	UVP in €: 30,90						



Schwenkdachwagen Tadgs der MAV
Swing roof car Tadgs of the MAV

							Handmuster
	NEU	VI	159	■	□	□	□
		NEM		→			NEM
Art.-Nr: 15353	UVP in €: 47,50						



Schiebewandwagen Habbins der MAV
Sliding wall box car Habbins of the MAV

		VI	194	■	□	□	□
		NEM		→			NEM
Art.-Nr: 15803	UVP in €: 41,90						



Handmuster

Gedeckter Güterwagen Ggu der GYSEV
Box car Ggu of the GYSEV

NEU	III	76	■	□	□	□
	NEM1	←	→		NEM	
Art.-Nr: 95216	UVP in €: 28,50					



Offener Güterwagen E der GYSEV
Open car E of the GYSEV

NEU	IV	83	■	□	□	□
	NEM1	←	→		NEM	
Art.-Nr: 17252	UVP in €: 17,50					



Kesselwagen Zaes der GYSEV, für Lebensmitteltransporte
Tank car Zaes of the GYSEV

	V	120	■	□	□	□
	NEM1	←	→		NEM	
Art.-Nr: 15475	UVP in €: 42,50					



Kesselwagen Zas „MOL“, eingestellt bei der GYSEV
Tank car Zas „MOL“ of the GYSEV

	VI	120	■	□	□	□
	NEM1	←	→		NEM	
Art.-Nr: 15467 A	UVP in €: 42,50					



Offener Güterwagen Eaos der GYSEV Cargo
Open freight var Eaos of the GYSEV Cargo

	VI	117	■	□	□	□
	NEM1	←	→		NEM	
Art.-Nr: 15257	UVP in €: 33,50					



Reisezugwagen der GYSEV, bestehend aus drei verschiedenen Reisezugwagen (AByz, Byz, BDyz)
 Passenger coach set of the GYSEV with three different passenger coaches

	VI NEM	664		
Art.-Nr: 01688	UVP in €: 134,90			



Reisezugwagen 2. Klasse Beelmt der JZ
 2nd class passenger coach Beelmt of the JZ

				Handmuster
NEU	V NEM	220		
Art.-Nr: 16509	UVP in €: 47,90			



Reisezugwagen der OSE, bestehend aus drei Reisezugwagen, Typ Y/B 70
 Passenger coach set of the OSE with three passenger coaches, type Y/B 70

NEU		IV	616		
Art.-Nr: 01697		UVP in €: 134,90			



Gedeckter Güterwagen
 „Weintransportwagen“, eingestellt
 bei den SBB
 Box car „Weintransportwagen“ of
 the SBB

	76	
Art.-Nr: 14127	UVP in €: 24,90	



Kesselwagen „PRIMAGAZ“, eingestellt
 bei den SBB
 Tank car „PRIMAGAZ“ of the SBB

NEU		74	
Art.-Nr: 95842	UVP in €: 30,90		



Diesellokomotive Am 4/4 der SBB
Diesel locomotive Am 4/4 of the SBB

NEU	IV	152				
Art.-Nr: 02505	UVP in €: 166,90					



Reisezugwagen 1. Klasse, Am, der SBB
1st class passenger coach Am of the SBB

		IV	220			
Art.-Nr: 13539	UVP in €: 47,90					



Liegewagen 2. Klasse, Bcm, der SBB
2nd class couchette coach Bcm of the SBB

		IV	220			
Art.-Nr: 13556	UVP in €: 47,90					



Offener Güterwagen Eaos der SBB
Open car Eaos of the SBB

		IV	117			
Art.-Nr: 15255	UVP in €: 33,50					



Niederbordwagen Res der SBB
Low side car Res of the SBB

		V	166			
Art.-Nr: 15587	UVP in €: 30,90					



Schwenkdachwagen Tds „AGRO-LINE“, eingestellt bei den SBB
Swing roof car Tds „AGRO-LINE“ of the SBB

Handmuster

NEU	V NEM	194 → ←	81 → ←	☐	☐	☐	☐	☐	☐	☐
Art.-Nr: 14591	UVP in €: 36,50									



Schiebewandwagen Habbis 345 der SBB
Sliding cover box car Habbis 345 of the SBB

	V NEM	194 → ←	☐	☐	☐	☐	☐	☐	☐	☐
Art.-Nr: 15802 A	UVP in €: 41,90									



Taschenwagen der HUPAC, beladen mit zwei Wechselpritschen „PLANZER“
Pocket wagon of the HUPAC with load

	V NEM	138 → ←	☐	☐	☐	☐	☐	☐	☐	☐
Art.-Nr: 18150	UVP in €: 41,90									



Elektrolokomotive E 186 der RAILPOOL GmbH, vermietet an SBB Cargo
Electric locomotive class 186 of the RAILPOOL GmbH, hired of the SBB Cargo

- Fernlicht schaltbar mit Decoder Art. 66023 / Main beam can be switched on by decoder item-no. 66023

VI NEM	158 → ←	☐	☐	☐	☐	☐	☐	☐	☐	☐	☐
Art.-Nr: 04907 A	UVP in €: 189,90										



Foto: TILLIG Werksarchiv



Reisezugwagen set der SBB, bestehend aus zwei Doppelstockwagen 2. Klasse, B-HVZ / Passenger coach set of the SBB with two different 2nd class double-deck coaches B-HVZ

VI NEM	448	E	Rmin 310	□-□-□-□-□ NEM
Art.-Nr: 01666		UVP in €: 104,90		



Doppelstockwagen 1./2. Klasse, AB-HVZ, der SBB
1st/2nd class double-deck coach AB-HVZ of the SBB

VI NEM	223	E	Rmin 310	□-□-□-□-□ NEM
Art.-Nr: 13807		UVP in €: 54,50		



Reisezugwagen 1. Klasse Am der SBB
1st class passenger coach Am of the SBB

	V NEM	VI NEM	220			
Art.-Nr: 13532		UVP in €: 47,90				



Liegewagen 2. Klasse Bcm der SBB
2nd class sleeping coach Bcm of the SBB

	VI NEM	220				
Art.-Nr: 13551		UVP in €: 47,90				



Schwenkdachwagen Tds der Centravo - GZM, eingestellt bei den SBB
Swing roof car Tds Centravo - GZM of the SBB

	VI NEM	81				
Art.-Nr: 14579		UVP in €: 36,50				



Staubbehälterwagen „Tela Recycling“, eingestellt bei den SBB
Silo car „Tela Recycling“ of the SBB

	VI NEM	159				
Art.-Nr: 15489 A		UVP in €: 44,90				



Schiebewandwagen „Tela“ der SBB
Sliding cover box car „Tela“ of the SBB

	NEU	VI NEM	194			
Art.-Nr: 15807		UVP in €: 41,90				

Handmuster



Kesselwagen Zas der VTG Schweiz GmbH
Tank car Zas of the VTG Schweiz GmbH

NEU	VI NEM	120	■-□-□-□
Art.-Nr: 15479	UVP in €: 42,50		



Offener Güterwagen L der FS
Open car L of the FS

NEU	III NEM	83	■-□-□-□
Art.-Nr: 17251	UVP in €: 17,50		



Staubsilowagen Mou „VTG“, ein-
gestellt bei der FS
Silo car Mou „VTG“ of the FS

NEU	III NEM	72	■-□-□-□
Art.-Nr: 17763	UVP in €: 33,50		



Reisezugwagen 1. Klasse Az der FS
1st class passenger coach Az of the FS

III NEM	IV NEM	220	L	■-□-□-□
Art.-Nr: 13538		UVP in €: 47,90		



Reisezugwagen 2. Klasse Bz der FS
2nd class passenger coach Bz of the FS

III NEM	IV NEM	220	L	■-□-□-□
Art.-Nr: 13552		UVP in €: 47,90		



Handmuster

FORMNEUHEIT: Selbstentladewagen „SGW“, eingestellt bei der SNCF
NEW: Hopper car „SGW“ of the SNCF

NEU	III NEM	83	■-□-□-□
Art.-Nr: 15171	UVP in €: 33,50		



Offener Güterwagen Tw der SNCF
 Open freight car Tw of the SNCF

III NEM	76	■-□-□-□
Art.-Nr: 17247	UVP in €: 19,90	



Kesselwagen Scwf „Andre Amioues“, eingestellt bei der SNCF
 Tank car Scwf „Andre Amioues“ of the SNCF

NEU	III NEM	74	■-□-□-□
Art.-Nr: 95843	UVP in €: 30,90		



Güterwagenset der SNCF, bestehend aus drei verschiedenen Staubsilowagen
 Freight car set of the SNCF with three different silo cars

IV NEM	214	■-□-□-□
Art.-Nr: 01681	UVP in €: 99,50	



Offener Güterwagen Eaos „SGW“, eingestellt bei der SNCF
 Open freight car Eaos „SGW“ of the SNCF
 • Ausführung mit gegossener Drehgestellbauart

IV NEM	117	■-□-□-□
Art.-Nr: 15258	UVP in €: 33,50	



Kesselwagen Uahs „ALGECO / TOTAL“, eingestellt bei der SNCF
 Tank car Uahs „ALGECO / TOTAL“ of the SNCF

NEU	IV NEM	120	
Art.-Nr: 15476	UVP in €: 42,50		



Kesselwagen Uahs „SIMOTRA / BP“, eingestellt bei der SNCF
 Tank car Uahs „SIMOTRA / BP“ of the SNCF

NEU	IV NEM	120	
Art.-Nr: 15477	UVP in €: 42,50		

Foto: J.H. Kolberg



Säurekesselwagen Uahs „ALGECO“, eingestellt bei der SNCF
 Acid tank car Uahs „ALGECO“ of the SNCF

NEU	IV NEM	120	
Art.-Nr: 15433	UVP in €: 39,90		



Staubbehälterwagen Uacs „Nord Mills/Ät mer bröd!“, eingestellt bei der SNCF
 Silo car Uacs "Nord Mills/Ät mer bröd!" of the SNCF

			Handmuster
NEU	V NEM	159	□-□-□-□-□-□ NEM
Art.-Nr: 15486	UVP in €: 44,90		



Offener Güterwagen Eaos der SNCF
 Open car Eaos of the SNCF

NEU	VI NEM	117	□-□-□-□-□-□ NEM
Art.-Nr: 15261	UVP in €: 33,50		



Kesselwagen der MILLET S.A.
 Tank car of the MILLET S.A.

	VI NEM	120	□-□-□-□-□-□ NEM
Art.-Nr: 15474	UVP in €: 42,50		



Säurekesselwagen „SOLVAY“, eingestellt bei der RENFE
 Tank car „SOLVAY“ of the RENFE

	V NEM	120	□-□-□-□-□-□ NEM
Art.-Nr: 15432	UVP in €: 39,90		



Kesselwagen „SCHOCK-STRENG Succ.“,
eingestellt bei der CFL
Tank car „SCHOCK-STRENG Succ.“ of the
CFL

NEU	III NEM	74	■-□-□-□-□ NEM
Art.-Nr: 95844	UVP in €: 30,90		



Diesellokomotive Reihe 1600 der CFL
Diesel locomotive class 1600 of the CFL

NEU	IV NEM	158	⊙⊙⊙	⌋	⊙⊙⊙⊙⊙ Flux12
Art.-Nr: 04537	UVP in €: 168,90				



Schiebeplanenwagen „EuroLuxCargo“
Sliding cover box car „EuroLuxCargo“

	V NEM	VI NEM	166	■-□-□-□-□ NEM
Art.-Nr: 15747	UVP in €: 36,50			



Dampflokomotive Reihe 26 der SNCB
Steam locomotive class 26 of the SNCB

NEU	III NEM	193	⊙⊙⊙	Rmin 310	■-□-□-□-□ NEM	⊙⊙⊙⊙⊙ NEM
Art.-Nr: 02288	UVP in €: 259,90					



Offener Güterwagen der SNCB
Open freight car of the SNCB

III NEM	76	■-□-□-□-□ NEM
Art.-Nr: 17248		
UVP in €: 18,50		



Offener Güterwagen
der SNCB
Open car of the SNCB

NEU	III NEM	76	■-□-□-□-□ NEM
Art.-Nr: 17249			
UVP in €: 19,90			

Handmuster



Reisezugwagen 1. Klasse Am der SNCB
1st class passenger coach, type Am, of the SNCB

		IV	220		
	NEM	NEM	NEM	NEM	NEM
Art.-Nr: 13537	UVP in €: 47,90				



Reisezugwagen 2. Klasse Bm der SNCB
2nd class passenger coach, type Bm, of the SNCB

		IV	220		
	NEM	NEM	NEM	NEM	NEM
Art.-Nr: 13554	UVP in €: 47,90				



Güterwagenset „TRANSCÉRÉALES / C.T.C.“, eingestellt bei der SNCB,
bestehend aus zwei Staubbehälterwagen
Freight car set „TRANSCÉRÉALES / C.T.C.“ of the SNCB with two silo cars

				Handmuster	
	NEU	IV	320		
	NEM	NEM	NEM	NEM	NEM
Art.-Nr: 01715	UVP in €: 88,90				



Gedeckter Güterwagen Gklm der SNCB
Box car Gklm of the SNCB

	NEU	IV	83		
	NEM	NEM	NEM	NEM	NEM
Art.-Nr: 17136	UVP in €: 24,90				

Handmuster



Elektrolokomotive Reihe 28 der SNCB
Electric locomotive 28 of the SNCB

- Fernlicht schaltbar mit Decoder Art. 66023 / Main beam can be switched on by decoder item-no. 66023

	VI NEM	158						Plus12
Art.-Nr: 04906 A	UVP in €: 187,90							

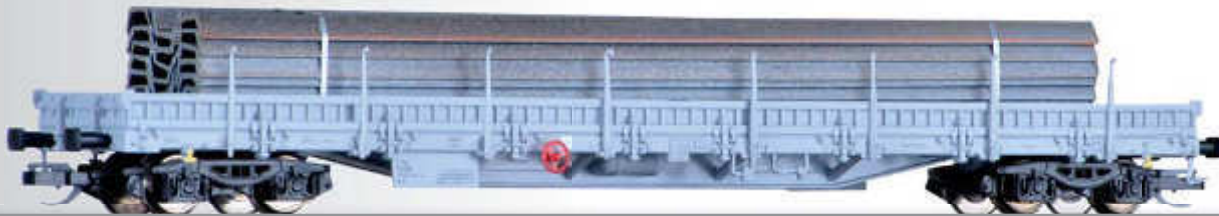

Niederbordwagen Rens der SNCB, beladen mit Spundwänden
Low side car Rens of the SNCB with load

	VI NEM	166					
Art.-Nr: 18100 A	UVP in €: 37,90						



Kesselwagen Zas der VTG (B-VTG)
Tank car Zas of the VTG (B-VTG)

NEU	VI NEM	120					
Art.-Nr: 15478	UVP in €: 42,50						



Gedeckter Güterwagen CHOK
der NS
Box car CHOK of the NS

NEU	III NEM	76					
Art.-Nr: 17135	UVP in €: 24,90						



Kesselwagen „Pieter Bon“,
eingestellt bei den NS
Tank car „Pieter Bon“ of the NS

NEU	IV NEM	92					
Art.-Nr: 17402	UVP in €: 36,50						



Handmuster

Schiebewandwagen Habbillns der Railion NL
Sliding cover box car Habbillns of the Railion NL

NEU	VI NEM	194 ← →	■ □ □ □ □ □ NEM
Art.-Nr: 15808	UVP in €: 41,90		



Kühlwagen IKI der DSB
Refrigerator car IKI of the DSB

III NEM	91 ← →	■ □ □ □ □ □ NEM
Art.-Nr: 14109	UVP in €: 26,90	



Kesselwagen der Dansk ESSO,
eingestellt bei der DSB
Tank car Dansk ESSO of the DSB

III NEM	92 ← →	■ □ □ □ □ □ NEM
Art.-Nr: 17400	UVP in €: 35,90	



Kesselwagen der „Jansen Benzin“,
eingestellt bei der DSB
Tank car „Jansen Benzin“ of the DSB

III NEM	74 ← →	■ □ □ □ □ □ NEM
Art.-Nr: 95837	UVP in €: 29,90	



Kesselwagen „BP“, eingestellt bei
den DSB
Tank car „BP“ of the DSB

NEU	III NEM	74 ← →	■ □ □ □ □ □ NEM
Art.-Nr: 95841	UVP in €: 30,90		



Kesselwagen „Dansk Sojakagefabrik“, eingestellt bei den DSB
Tank car “Dansk Sojakagefabrik” of the DSB

NEU	III NEM	74	■-□	□-■
Art.-Nr: 95845	UVP in €: 30,90			



Kesselwagen „NYNÄS“, eingestellt bei der SJ
Tank car “NYNÄS” of the SJ

NEU	III NEM	76	■-□	□-■
Art.-Nr: 17305	UVP in €: 26,90			



Kesselwagen Zkk der NYNÄS, eingestellt bei der SJ
Tank car Zkk NYNÄS of the SJ

	IV NEM	92	■-□	□-■
Art.-Nr: 14998 A	UVP in €: 35,90			



Schiebewandwagen Habis Skandiatransport, eingestellt bei der SJ
Sliding cover box car Habis Skandiatransport of the SJ

	IV NEM	194	■-□	□-■
Art.-Nr: 15805	UVP in €: 41,90			

Unsere START-Modelle für alle jungen TT-Modellbahnfans



- Ausgestattet mit Beleuchtung/With lightning

START-Diesellokomotive BR 203
„Bahnau“ der DB AG
START-Diesel locomotive class 203
„Bahnau“ of the DB AG

- Ausgestattet mit Beleuchtung /
With lightning

Art.-Nr: 04598

UVP in €: 98,50



Speisewagen „MITROPA“ der DR
Dining car „MITROPA“ of the DR

Art.-Nr: 13239

UVP in €: 16,50



Personenwagen der DR
Passenger coach of the DR

Art.-Nr: 13228

UVP in €: 16,50

Ab dem Produktionsjahr 2016 werden unsere START-Modelle komplett mit den aktuellen TILLIG-Kupplungen ausgestattet.
From 2016 our START-models are complete equipped with current TILLIG-coupling.



START-Diesellokomotive BR 218
in „InterCity“-Lackierung
„START“-Diesel locomotive class 218
in colouring of „InterCity“

- Ausgestattet mit Beleuchtung /
With lightning

Art.-Nr: 02709

UVP in €: 94,90



Reisezugwagen 1. Klasse der DB AG,
in „InterCity“-Lackierung
1st class passenger coach of the DB AG,
in colouring of „InterCity“

Art.-Nr: 13625

UVP in €: 18,90



Reisezugwagen 2. Klasse der DB AG,
in „InterCity“-Lackierung
2nd class passenger coach of the DB AG,
in colouring of „InterCity“

Art.-Nr: 13626

UVP in €: 18,90



Reisezugwagen BD der DB AG,
in „InterCity“-Lackierung
Passenger coach BD of the DB AG,
in colouring of „InterCity“

Art.-Nr: 13609

UVP in €: 18,90



Speisewagen „Bord Bistro“ in
„InterCity“-Lackierung/Dining car
„Bord Bistro“ in colouring of „InterCity“

Art.-Nr: 13759

UVP in €: 17,50



Niederbordwagen mit Plane „Holzwolle“
Low side car with tarpaulin

Art.-Nr: 14649

UVP in €: 11,90

- Mit abnehmbarer Plane/With a tarpaulin sheet that can be removed



Kühlwagen „Interfrigo“
Refrigerator car „Interfrigo“

Art.-Nr: 14148

UVP in €: 11,90



Offener Güterwagen „Schüttgut-Verkehr“
Open car „Schüttgut-Verkehr“

Art.-Nr: 14269

UVP in €: 11,50



Gedeckter Güterwagen „Expressgut“
Freight car for transport of parcel

Art.-Nr: 14117

UVP in €: 11,90

Ab dem Produktionsjahr 2016 werden unsere START-Modelle komplett mit den aktuellen TILLIG-Kupplungen ausgestattet.
From 2016 our START-models are complete equipped with current TILLIG-coupling.



Gleiserweiterungs-Set „Bahnhof“ bestehend aus:

- 1 Handweiche, rechts (83816) mit Ausgleichsstück (83722)
- 1 Handweiche, links (83817) mit Ausgleichsstück (83721)
- 7 geraden Gleisen (83701)
- 1 geraden Gleis (83705)
- 1 geraden Gleis (83703)
- 4 geraden Gleisen (83704)
- 2 gebogenen Gleisen (83707)
- 4 Isolierschienenverbindern (83952)
- 2 Schienenverbindern mit Anchlusselement (83951)
- Bedienungsanleitung mit Gleis- und Anschlussplan

- 1 BW, right (83816) with hand drive and compatible unit (83722)
- 1 BW, left (83817) with hand drive and compatible unit (83721)
- 7 straight tracks (83701)
- 1 straight track (83705)
- 1 straight track (83703)
- 4 straight tracks (83704)
- 2 curved tracks (83707)
- 4 Isolated rail joiners (83952)
- 2 rail joiners with connecting element (83951)
- manual with track and wiring diagramm

Art.-Nr: 01833

UVP in €: 56,90

Mit diesem Set lässt sich das Gleisoval der Sets, Art.-Nr.: 01424ff auf ein Oval mit zweigleisigem Bahnhof ausbauen. Im Falle der Nutzung abschaltbarer Gleisabschnitte werden zusätzlich ein Tastenpult (Art. 08211) sowie Schaltlitze (Art. 08972) benötigt.

You can build the circular line of the set, item-no.: 01424 ff on an oval track with a railway station with two lines with this set. If you use track sections that can be disconnected a railway push button panel (item-no. 08211) as well as a stranded wire (item-no. 08972) are required.

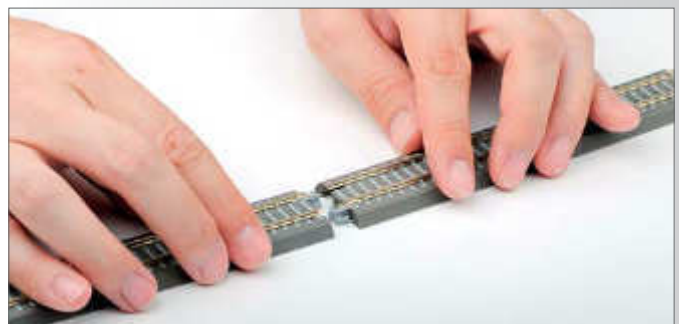

Zusätzliche Gleiserweiterungs-Sets zum Ausbau der Einsteiger-Sets More track extension sets for the expansion of the beginner sets

Gleiserweiterungs-Set „Parallelkreis Teil 1“: Track extension set „parallel circuit part 1“:

- 1 Innenbogenweiche, rechts (83861) mit Ausgleichsstück (83726) / 1 curved points, right (83861) with curved compatible unit, left (83726)
- 1 Innenbogenweiche, links (83862) mit Ausgleichsstück (83725) / 1 curved points, left (83862) with curved compatible unit, right (83725)
- 4 gebogene Gleise (83706) / 4 curved tracks (83706)
- 4 gerade Gleise (83701) / 4 straight tracks (83701)
- 2 gerade Gleise (83704) / 2 straight tracks (83704)
- 1 gerades Gleis (83702) / 1 straight track (83702)

Art.-Nr: 01834
UVP in €: 55,90



Gleiserweiterungs-Set „Parallelkreis Teil 2“: Track extension set „parallel circuit part 2“:

- 1 Innenbogenweiche, rechts (83861) mit Ausgleichsstück (83726) / 1 curved points, right (83861) with curved compatible unit, left (83726)
- 1 Innenbogenweiche, links (83862) mit Ausgleichsstück (83725) / 1 curved points, left (83862) with curved compatible unit, right (83725)
- 4 gebogene Gleise (83706) / 4 curved tracks (83706)
- 5 gerade Gleise (83701) / 5 straight tracks (83701)
- 4 gerade Gleise (83705) / 4 straight tracks (83705)

Art.-Nr: 01835
UVP in €: 58,90



Gleiserweiterungs-Set „Rangierbahnhof“: Track extension set „railroad shunting yard“:

- 2 Handweichen, rechts (83816) mit Ausgleichsstück (83722) / 2 BW, right (83816) with hand drive and compatible unit (83722)
- 1 Handweiche, links (83817) mit Ausgleichsstück (83721) / 1 BW, left (83817) with hand drive and compatible unit (83721)
- 5 gerade Gleise (83701) / 5 straight tracks (83701)
- 1 gerades Gleis (83702) / 1 straight track (83702)
- 1 gerades Gleis (83705) / 1 straight track (83705)
- 3 Prellböcke mit Gleisstück (83700) / 3 buffer stops with track (83700)

Art.-Nr: 01836
UVP in €: 69,50



Elektrifizierungs-Set: Electrification set:

- 9 Weichenantriebe (83960) / 9 electric point mechanism (83960)
- 3 Tastenpulte (08211) / 3 control desks (08211)
- 1 Schalllitze (08972) / 1 stranded hook-up wire (08972)

Art.-Nr: 01837
UVP in €: 149,00

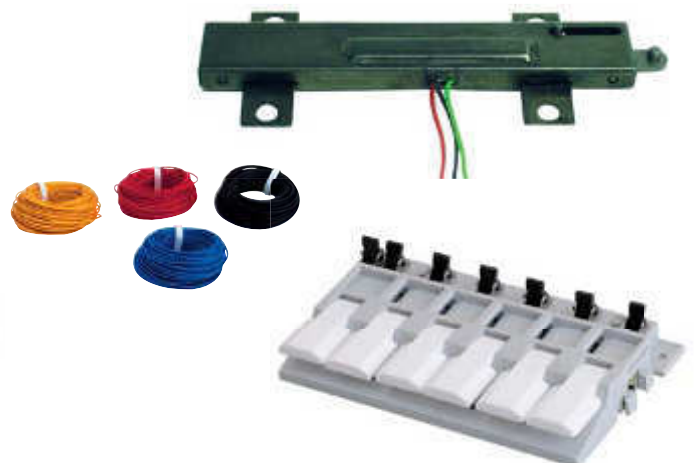



Einsteiger-Set: Güterzug der DB AG, bestehend aus/
Beginner set of the DB AG with:

		Lok			
VI	522	Plux12	NEM		
Art.-Nr: 01424		UVP in €: 144,90			

- Diesellokomotive „TRAXX“ BR 285 mit zwei Güterwagen / Diesel locomotive „TRAXX“ class 285 with two freight cars
- Bettungsgleisoval, TILLIG-Fahrregler (ohne Zubehörausgang) / Bedding track, TILLIG-Controller (without accessory output)
- Container, Straßenfahrzeug, Aufgleiser, Handentkuppler / container, car, reailer, manual uncoupler

**Zusätzlich enthalten unsere Einsteiger-Sets
01424, 01431, 01432, 01434, 01437 und
01438:**

- Einen 10,- € Gutschein für den Kauf eines Gleiserweiterungssets (01833 - 01837), Seite 175-176
- 1 Eintrittskarte für das TILLIG-Museum
- 1 coupon of 10,- € for buying of the TILLIG-track-set (item.-no. 01833-01837), page 175-176
- 1 coupon for free entrance at the TILLIG-Museum



START-Set 01424
Platzbedarf / Space requirements:
70 x 85 cm





Einsteiger-Set: Güterzug der ČD, bestehend aus /
Beginner set of the ČD with:

	VI NEM	522	⊕ ⊖	⊕ ⊖	⊕ ⊖	⊕ ⊖	⊕ ⊖	Lok
					Plus12		NEM	
Art.-Nr: 01431				UVP in €: 144,90				

- Diesellokomotive „TRAXX“ mit zwei Güterwagen / Diesel locomotive „TRAXX“ and two freight cars
- Bettungsgleisoval, TILLIG-Fahrregler (ohne Zubehörausgang) / Bedding track, TILLIG-Controller (without accessory output)
- Container, Straßenfahrzeug, Aufgleiser, Handentkuppler / container, road vehicle, reailer, manual uncoupler



Hinweis / Note:

Alle Einsteiger-Sets enthalten den TILLIG-Fahrregler!
Das Auto und der Container können je nach Set variieren.
All sets are equipped with the TILLIG-Controller!
The car and the container can be various.



Set 01432

Einsteiger-Set: Güterzug der PKP, bestehend aus /
Beginner set of the PKP with:

	VI NEM	522	⊕ ⊖	⊕ ⊖	⊕ ⊖	⊕ ⊖	⊕ ⊖	Lok
					Plus12		NEM	
Art.-Nr: 01432				UVP in €: 144,90				

- Diesellokomotive „TRAXX“ mit zwei Güterwagen / Diesel locomotive „TRAXX“ and two freight cars
- Bettungsgleisoval, TILLIG-Fahrregler (ohne Zubehörausgang) / Bedding track, new TILLIG-Controller (without accessory output)
- Container, Straßenfahrzeug, Aufgleiser, Handentkuppler / container, car, reailer, manual uncoupler

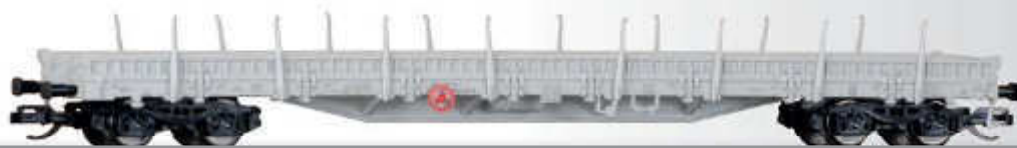

Einsteiger-Set: Güterzug der SBB, bestehend aus
Beginner set of the SBB with:

- Diesellokomotive „TRAXX“ mit zwei Güterwagen / Diesel locomotive „TRAXX“ with two freight cars
- Bettungsgleisoval, TILLIG-Fahrregler (ohne Zubehörausgang) / Bedding track, new TILLIG-Controller (without accessorie output)
- Container, Straßenfahrzeug, Aufgleiser, Handentkuppler / container, car, rereiler, manual uncoupler

VI		522		Lok	
NEM		← →		Plux12 NEM	
Art.-Nr: 01434				UVP in €: 144,90	

**Zusätzlich enthalten unsere Einsteiger-Sets
01424, 01431, 01432, 01434, 01437 und 01438:**

- *Einen 10,- € Gutschein für den Kauf eines Gleiserweiterungssets (01833 - 01837), Seite 175-176*
- *1 Eintrittskarte für das TILLIG-Museum*
- *1 coupon of 10,- € for buing of the TILLIG-track-set (item.-no. 01833-01837), page 175-176*
- *1 coupon for free entrance at the TILLIG-Museum*

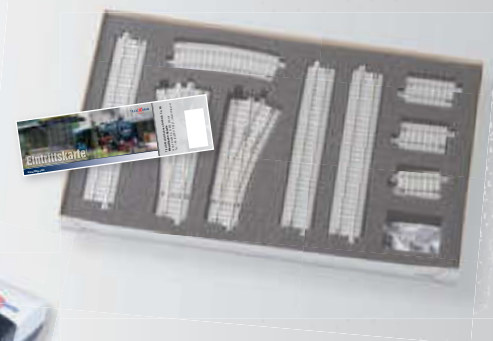

Einsteiger-Sets



Einsteiger-Set: Personenzug der DB AG, bestehend aus:
 Diesellokomotive TRAXX mit zwei Personenwagen
 Beginner set of the DB AG with:
 Diesel locomotive TRAXX with two passenger coaches

NEU	VI NEM	466	Wagen		Lok		Handmuster
Art.-Nr: 01437			UVP in €: 144,90				

Die beiden Sets auf dieser Seite enthalten / these two sets consisting of:

- Bettungsgleisoval, TILLIG-Fahrregler (ohne Zubehörausgang) / Bedding track, new TILLIG-Controller (without accessory output)
- Container, Straßenfahrzeug, Aufgleiser, Handentkuppler / container, car, rerailer, manual uncoupler

Zusätzlich enthalten unsere Einsteiger-Sets
 01424, 01431, 01432, 01434, 01437 und 01438:

- Einen 10,- € Gutschein für den Kauf eines Gleiserweiterungssets (01833 - 01837), Seite 175-176
- 1 Eintrittskarte für das TILLIG-Museum
- 1 coupon of 10,- € for buying of the TILLIG-track-set (item.-no. 01833-01837), page 175-176
- 1 coupon for free entrance at the TILLIG-Museum



Inklusive
TILLIG-Fahrregler!



START-Sets 01437, 01438
 Platzbedarf / Space requirements:
 70 x 85 cm

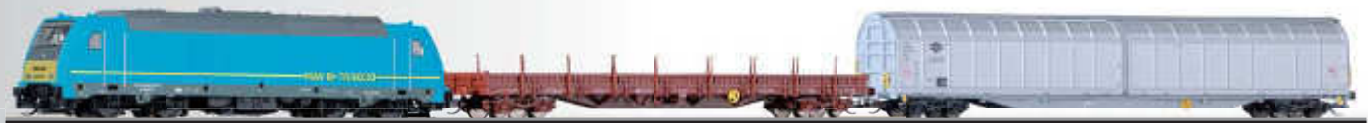

Einsteiger-Set: Güterzug der MAV, bestehend aus:
 Diesellokomotive TRAXX mit zwei Güterwagen
 Beginner set of the MAV with:
 Diesel locomotive TRAXX with two freight cars

NEU	VI NEM	522	Lok		Handmuster	
Art.-Nr: 01438			UVP in €: 144,90			





Personenzug-Set der DR, bestehend aus/
Passenger coach set of the DR with:

Lok	Wagen	Lok
Art.-Nr: 01425		UVP in €: 219,00

- Diesellokomotive BR 110 mit zwei E5-Wagen/Diesel locomotive class 110 with two passenger coaches E5
- Modellgleisoval mit Abstellgleis, TILLIG-Fahrregler (ohne Zubehörausgang)/
Advanced-track-oval with siding, TILLIG-Controller (without accessory output)
- Straßenfahrzeug, Aufgleiser, Handentkuppler/road vehicle, re-railer, manual uncoupler

Zusätzlich enthält unser Einsteiger-Sets 01425:

- 1 Eintrittskarte für das TILLIG-Museum
- 1 coupon for free entrance at the TILLIG-Museum



Set 01425



Personenzug-Set der DB, bestehend aus/
Passenger coach set of the DB with:

- Diesellokomotive V 80 mit drei Personenwagen/
Diesel locomotive class V 80 with three passenger coaches
- Modellgleisoval mit Abstellgleis, neuer TILLIG-Fahrregler (ohne Zubehörausgang)/
Advanced-track-oval with siding, new TILLIG-Controller (without accessory output)
- Straßenfahrzeug, Aufgleiser, Handentkuppler/road vehicle, re-railer, manual uncoupler

Lok		Lok	
	473		
Art.-Nr: 01426		UVP in €: 229,00	

Zusätzlich enthält unser Einsteiger-Sets 01425:

- 1 Eintrittskarte für das TILLIG-Museum
- 1 coupon for free entrance at the TILLIG-Museum



Set 01426



Trabant 601 Kombi
„Deutsche Reichsbahn“
Trabant 601 estate car
„Deutsche Reichsbahn“

Art.-Nr: 08737 A UVP in €: 8,50



Trabant 601 Kombi
„VEB Energieversorgung“
Trabant 601 estate car
„VEB Energieversorgung“

Art.-Nr: 08738 A UVP in €: 8,50



Trabant 601 Kombi
Trabant 601 estate car

Art.-Nr: 08739 A UVP in €: 8,50

NEU



Trabant 601 Kombi
„MITROPA“
Trabant 601 Kombi
„MITROPA“

Art.-Nr: 08740 UVP in €: 8,50

NEU



Trabant 601 Kombi „LPG
Roter Oktober“
Trabant 601 estate car „LPG
Roter Oktober“

Handmuster

Art.-Nr: 08741 UVP in €: 8,50



Wartburg 353 „Feuerwehr“
Wartburg 353 „Feuerwehr“

Art.-Nr: 08690 UVP in €: 10,50



Wartburg 353 „DRK“
Wartburg 353 „DRK“

Art.-Nr: 08691 A UVP in €: 10,50



Wartburg 353 de Luxe
Wartburg 353 deLuxe

Handmuster

Art.-Nr: 08692 A UVP in €: 10,50



Handmuster

Matador Kastenwagen
„Landmaschinenhandel
Schepperle“
Matador van „Landmaschinen-
handel Schepperle“

Art.-Nr: 08608 UVP in €: 11,90



Matador Kastenwagen
„Deutsche Bundespost“
Matador van „Deutsche
Bundespost“

Art.-Nr: 08609 UVP in €: 11,90



Matador Kastenwagen
„Deutsche Bundesbahn“
Matador van
„Deutsche Bundesbahn“

Art.-Nr: 08632 A UVP in €: 11,90



Matador Kastenwagen
„Molkerei Sauer“
Matador van
„Molkerei Sauer“

Art.-Nr: 08633 A UVP in €: 11,90



Matador Kastenwagen „Lindt“
Matador van „Lindt“

Handmuster

Art.-Nr: 08634 UVP in €: 11,90

NEU



LKW H3A mit Anhänger „VEB Kraftverkehr Eisenhüttenstadt“
Truck H3A and truck trailer „VEB Kraftverkehr Eisenhüttenstadt“

Handmuster

Art.-Nr: 08637 UVP in €: 27,50



LKW H3A „VEB Kraftverkehr
Eisenach“, beladen
mit Rollgutbehälter
Truck H3A „VEB Güterkraft-
verkehr Eisenach with load

Art.-Nr: 08795 A UVP in €: 16,50



LKW H3A „VEB Leuna“
Tank truck H3A „VEB Leuna“

Art.-Nr: 08796 A UVP in €: 14,90



LKW H3A Tankwagen
„LEUNA-LEIME“
Tank truck H3A
„LEUNA LEIME“

Art.-Nr: 08797 A UVP in €: 16,50



LKW H3A Tankwagen
„DRK“
Tank truck H3A „DRK“

Art.-Nr: 08798 A UVP in €: 16,50



LKW H3A „VEB Energieversorgung“, beladen mit Kisten
Truck H3A „VEB Energieversorgung“ with load

Art.-Nr: 19001 A UVP in €: 16,50



LKW H3A „VEB Lockwitzgrund“ beladen mit Fässern
Truck H3A „VEB Lockwitzgrund“ with load

Art.-Nr: 19002 A UVP in €: 16,50



LKW H3A „LPG Roter Oktober“ beladen mit Benzinfässern
Truck H3A „LPG Roter Oktober“ with load

Art.-Nr: 19003 UVP in €: 16,50



FORMNEUHEIT: LKW H3A Kofferaufbau „Deutsche Post“
NEW: Truck H3A box „Deutsche Post“

Art.-Nr: 19004 UVP in €: 18,50



FORMNEUHEIT: LKW H3A Kofferaufbau „KONSUM Fleischwaren“
NEW: Truck H3A box „KONSUM Fleischwaren“

Art.-Nr: 19005 UVP in €: 18,50



FORMNEUHEIT: LKW H3A Kofferaufbau „MITROPA“
NEW: Truck H3A box „MITROPA“

Art.-Nr: 19006 UVP in €: 18,50



FORMNEUHEIT: LKW H3A Kipper „VEB Bau-Union“
NEW: Dump truck H3A „VEB Bau-Union“

Art.-Nr: 19007 UVP in €: 18,50



FORMNEUHEIT: LKW H3A Kipper „Stadtreinigung“
NEW: Dump truck H3A „Stadtreinigung“

Art.-Nr: 19008 UVP in €: 18,50



FORMNEUHEIT: LKW H3A Hochbordpritsche / Plane „Feuerwehr“
NEW: Truck H3A platform / tarpaulin „Feuerwehr“

Art.-Nr: 19009 UVP in €: 18,50



FORMNEUHEIT: LKW H3A Hochbordpritsche/Plane „Zwickauer Bier“
NEW: Truck H3A platform / tarpaulin „Zwickauer Bier“

Art.-Nr: 19010 UVP in €: 18,50



LKW Robur LO 1801 Kofferaufbau; „Deutsche Post“ / Truck Robur LO 1801 „Deutsche Post“

Art.-Nr: 19020 A UVP in €: 18,50



FORMNEUHEIT: LKW Robur LO 1801 Kofferaufbau „Deutsches Rotes Kreuz“
NEW: Truck Robur LO 1801 box „Deutsches Rotes Kreuz“

Art.-Nr: 19021 UVP in €: 18,50



FORMNEUHEIT: LKW Robur LO 1801 Pritsche/Plane „Militärstreife/NVA“
NEW: Truck Robur LO 1801 platform / tarpaulin „Militärstreife/NVA“

Art.-Nr: 19022 UVP in €: 18,50



FORMNEUHEIT: LKW Robur LO 1801 Pritsche/Plane „Feuerwehr“
NEW: Truck Robur LO 1801 platform / tarpaulin „Feuerwehr“

Art.-Nr: 19023 UVP in €: 18,50



LKW MAN mit Containeraufleger und zwei Containern
Truck MAN with semi-trailer loaded with two containers
two containers

Art.-Nr: 08712 A

UVP in €: 27,50

NEU



LKW ROMAN mit Kofferaufleger „Spezitex / VEB Kraftverk. Meißen“
Truck ROMAN with trailer „Spezitex / VEB Kraftverk. Meißen“

Art.-Nr: 08713

UVP in €: 27,50

NEU



LKW RABA mit Pritschenaufleger „VEB ITVK“, mit Ladung
Truck RABA with semi-trailer „VEB ITVK“ with load

Art.-Nr: 08714

UVP in €: 27,50

Handmuster



LKW Roman mit Containeraufleger beladen mit zwei Containern
Truck Roman with semi-trailer loaded with two containers

Art.-Nr.: 501137 A

UVP in €: 27,50



Set mit zwei Schützenpanzern BMP-1
Set with two tanks BMP-1

- Ohne Bedruckung für universellen Einsatz / Without printing, for universal application

Art.-Nr: 07745

UVP in €: 21,90



Set mit zwei Panzern T 34/85
Set with two tanks T34/85

- Ohne Bedruckung für universellen Einsatz / Without printing, for universal application

Art.-Nr: 07750

UVP in €: 21,90



Container-Set mit drei 20" Containern
Container set three 20" container

Art.-Nr: 07708 A UVP in €:10,20

NEU



Drei Behälter „Haus-zu-Haus“
Three container „Haus-zu-Haus“

Art.-Nr: 07723 UVP in €: 8,45



Digitale Steuerung des Anlagenbetriebes

Vorteile der digitalen Steuerung:

- Mehrere Triebfahrzeuge sind unabhängig voneinander auf dem selben Stromkreis steuerbar. So lassen sich vorbildentsprechende Betriebssituationen wesentlich einfacher nachbilden als mit analoger Steuerung.
- Die digitale Steuerung benötigt für gleichzeitigen Fahrbetrieb mehrerer Züge keine Unterteilung der Anlage in verschiedene Stromkreise.
- Bessere Fahreigenschaften als im konventionellen Betrieb: Hervorragende Langsamfahreigenschaften, konstante Geschwindigkeiten unabhängig von der Zuglast durch lastgeregelte Decoder
- Simulation einer Anfahr- und Bremsbeschleunigung
- Konstante Zugbeleuchtung
- Zusatzfunktionen wie Licht oder Sound sind getrennt voneinander und funktionieren auch im Stand
- Verringerter Verdrahtungsaufwand durch digitale Ansteuerung der Zubehördecoder

Prinzip der Digitalsteuerung:

- Steuerung basiert auf einem „intelligenten“ Fahrregler (Zentrale)
- Als „Übersetzer“ der Signale der Zentrale zur Lok dient ein Decoder, der in die Lok eingebaut wird
- Am Gleis liegt ständig eine konstante Spannung an (im Gegensatz zum konventionellen Analogbetrieb, wo die Geschwindigkeit mit der Höhe der Spannung geregelt wird)
- Für die Erteilung von Fahrbefehlen durch die Zentrale erhält jede Lok eine „Adresse“.

- Die Lok reagiert nur auf Befehle der Zentrale, wenn diese auf die Adresse der Lok bezogen sind. Zu den Befehlen zählen z. B.: Regelung der Geschwindigkeit, Wahl der Fahrtrichtung, Schalten von Licht- und Soundfunktionen
- Es können mehrere Loks auf demselben Gleis unterschiedliche Fahrzustände – unabhängig voneinander – einnehmen
- Die Decoder können in ihren Eigenschaften eingestellt werden (Programmieren) z. B. Adresse der Lok, Anfahr- und Bremsverzögerung

Das Digitalsystem bei TILLIG:

TILLIG liefert im Herbst 2014 das neue Digital-System in Kooperation mit der Firma Uhlenbrock. Auf den S. 188/189 erhalten Sie zu unseren neuen Digital-Einsteigersets diverse Detailinformationen. Diese Sets enthalten dann auch die neuen Digitalkomponenten der Fa. Uhlenbrock.

Hinweis zur Umrüstung konventioneller Triebfahrzeuge auf Digitalbetrieb:

Diese erfolgt durch Mini-Decoder (siehe S. 190), die auch in älteren und kleineren TT-Lokomotiven verwendet werden können. Für weniger handwerklich begabte Modellbahner bietet die Firma TILLIG die Ausrüstung der ehemaligen TILLIG Modelle ab Baujahr 1995 und der Modelle aus eigener Produktion mit Decodern an. Auf Wunsch können alle Loks (Ausnahme E 44) ab Werk digitalisiert werden. Bitte dies bei Ihrer Bestellung im Fachhandel angeben!

Digitalization of model railway system operation

Advantages of digital control:

- Several power units can be controlled independent from each other. So you can imitate realistic operating situations better than an analogue control.
- With digital control it is not necessary to divide the set into several track sections for traction operations of several trains at the same time.
- Better driving characteristics than in conventional operation: excellent characteristics in driving slowly, with the decoder you have a constant speed independent of load.
- Simulation of starting and braking acceleration
- Constant train lighting
- Additional functions like light and sound are separate and even works in stop
- Less work for wiring because activation of decoder for additional parts occurs by the track

Principle of digital control

- Control is based on an „intelligent“ controller
- A decoder integrated in the locomotive is „translating“ the signals from control centre to the locomotive
- On the track a constantly voltage is still applied (in contrast to conventionally analogue operation where speed is controlled by voltage)

- Each locomotive has got an address to get propulsion command from control centre
- The locomotive only responds to instructions from control centre which refers to their address. These are instructions like controlling speed, to choose driving direction, to switch light and sound functions)
- Several locomotives on the same track can have different driving conditions – independently from each other
- The decoders can be programmed e.g. the address of the locomotive, starting / braking delay to simulate the loads of the train

The digital system of TILLIG:

TILLIG will deliver in autumn 2014 the new digital system in cooperation with the firm Uhlenbrock. On pages 188/189 you got various informations about our new digital beginner sets. These sets will also include the new digital components from the firm Uhlenbrock.

Tip to convert conventional power units to digital operation:

The conversion is made by mounting Mini-Decoder (page 190) which can also be used in older and smaller TT-locomotives. TILLIG offers you to convert former ZEUGE / BTTB models and models from our own production with decoders. On request all locomotives (excepting E 44) are available digital equipped. Please quote when ordering at your speciality retailer.

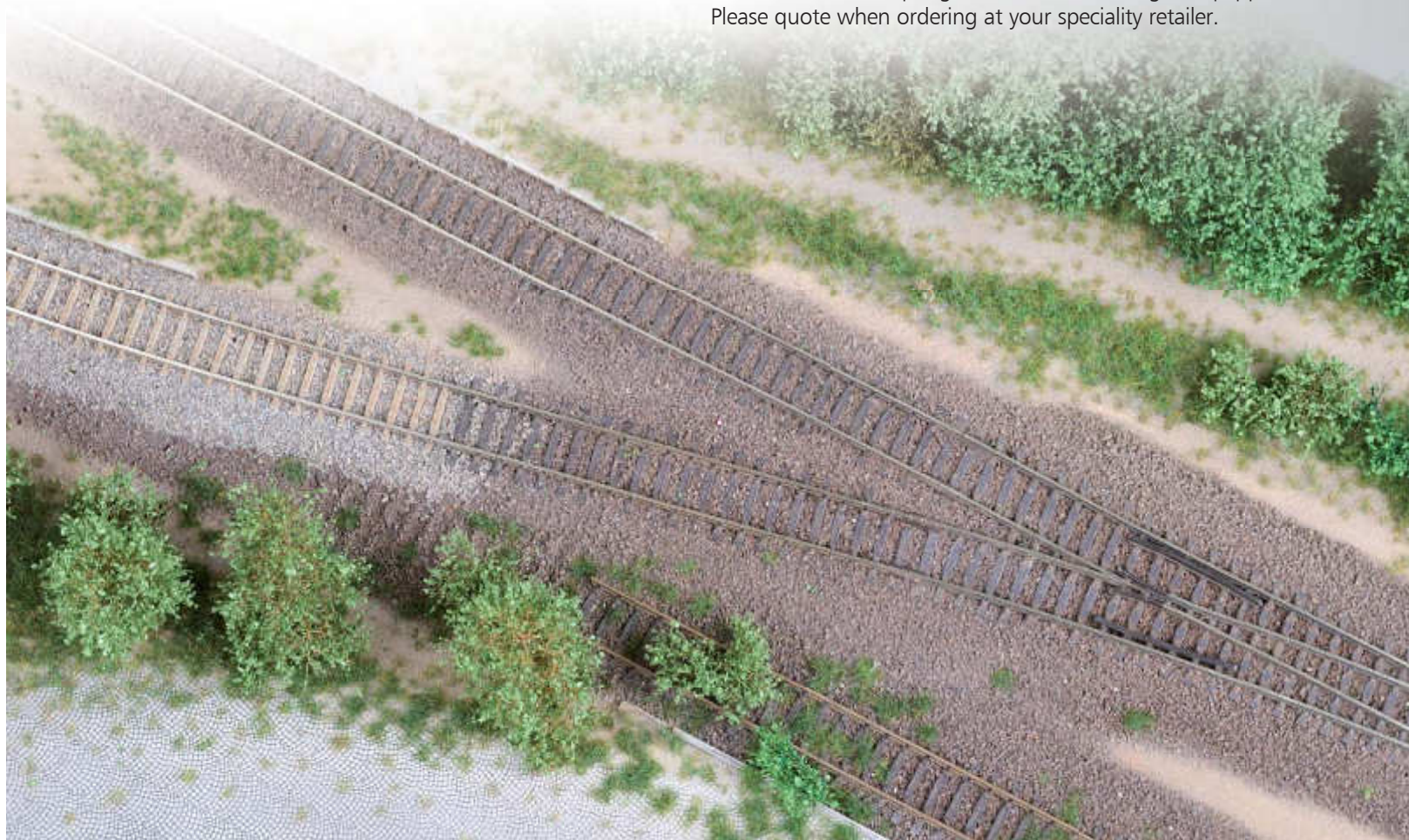

DIGITAL



Digital-Einsteiger-Set: Güterzug der DR, bestehend aus / Digital beginner set of the DR with:

- Diesellokomotive BR 110 mit Digital-Decoder und vier verschiedenen Wagen / Diesel locomotive class 110 with digital-decoder and four different cars

				Lok	Lok
	IV	480	⊕ ⊖	⊕ ⊖	⊕ ⊖
	NEM			NEM	NEM 662
Art.-Nr: 01208		UVP in €: 389,00			

Die Sets dieser Doppelseite enthalten / this sets consisting of:

- Digitalgrundausstattung in Kooperation mit Uhlenbrock Elektronik GmbH: Zentraleinheit mit Verstärker, Handregler, Stromversorgung (Netzteil) / digital assecoires in cooperation with Uhlenbrock Elektronik GmbH: command station, manual control, AC adapter
- Modellgleisoval mit Abstellgleis (70 x 100 cm), elektrischer Weichenantrieb / Advanced-track-oval with siding (70 x 100 cm), electric operating gear
- Straßenfahrzeug, Aufgleiser, Handentkuppler / road vehicle, rerailer, manual uncoupler



Set 01207

Digital-Einsteiger-Set: Güterzug der DB, bestehend aus / Digital beginner set of the DB with:

- Diesellokomotive V 80 mit Digital-Decoder und vier verschiedenen Wagen / Diesel locomotive class V 80 with digital-decoder and four different cars

				Lok	Lok
	III	469	⊕ ⊖	⊕ ⊖	⊕ ⊖
	NEM			NEM	NEM
Art.-Nr: 01207		UVP in €: 389,00			

DIGITAL



Abb. zeigt Modelle 02175 - 501262 - 13014

Digital-Einsteiger-Set: Personenzug der PKP, bestehend aus:
Dampflokomotive Reihe TKt3 und drei Nebenbahn-Personenwagen
Digital beginner set: Passenger coach set of the PKP with:
Steam locomotive class TKt3 and three passenger coaches

NEU	III NEM1	467	oooo	⚡	□-□-□-□ NEM	□-□-□-□ NEM
Art.-Nr: 01210		UVP in €: 389,00				



Abb. zeigt Modelle 02180 - 13009 - 13018

Digital-Einsteiger-Set: Personenzug der ČSD, bestehend aus:
Dampflokomotive Reihe 455.2 und drei Nebenbahn-Personenwagen
Digital beginner set: Passenger coach set of the ČSD with:
Steam locomotive class 455.2 and three passenger coaches

NEU	III NEM1	467	oooo	⚡	□-□-□-□ NEM	□-□-□-□ NEM
Art.-Nr: 01211		UVP in €: 389,00				



Abb. zeigt Modelle 02687 - 15246

Digital-Einsteiger-Set: Güterzug der DR, bestehend aus:
Diesellokomotive BR 118 C'C' mit Sound und drei offenen Güterwagen Eas
Digital beginner set: Freight car set of the DR with:
Diesel locomotive class 118 C'C' with sound and three open freight cars Eas

NEU	III NEM1	519	Wagen		Lok	
			□-□-□-□ NEM	oooo	⚡	□-□-□-□ H0x12
Art.-Nr: 01209		UVP in €: 525,00				



Abb. zeigt Modelle 04535 - 15256

Digital-Einsteiger-Set: Güterzug der MAV, bestehend aus:
Diesellokomotive Reihe M61 mit Sound und drei offenen Güterwagen Eaos
Digital beginner set: Freight car set of the MAV with sound with:
Diesel locomotive class M61 with sound and three open freight cars Eaos

NEU	IV NEM1	515	Wagen		Lok	
			□-□-□-□ NEM	oooo	⚡	□-□-□-□ H0x12
Art.-Nr: 01212		UVP in €: 525,00				

Verwendung der verschiedenen Decodertypen in TILLIG-Fahrzeugen/Use of the various decoder types in TILLIG vehicles

x ... Empfohlener Einsatz des Decoders/Recommended use of the decoder

o ... Einsatz des Decoders möglich, aber nicht Nutzung aller Funktionen möglich/Use of the decoder is possible but the use of all functions is not possible

	Loks mit 6-poliger Schnittstelle zum Löten Locomotives with 6 pole interface for soldering	Loks mit 6-poliger Steck-Schnittstelle Locomotives with 6 pole insertion interface	Fahrzeuge mit 6-poliger Steck-Schnittstelle und zusätzlichen Anschlüssen zum Löten Vehicles with 6 pole insertion interface and additional connections for soldering	Loks mit PluX12 Schnittstelle Locomotives with PluX12 interface	Loks mit Next18 Schnittstelle Locomotives with Next18 interface
Symbol/Symbols					
Beispiele/Examples	Diesellok V 100, V36 ältere TILLIG-Loks Diesel locomotive class V 100 and older TILLIG-Locomotives	Alle Dampfloks aus dem aktuellen TILLIG-Sortiment; V 60, VT 137, E 10.3, E 11/42, E 10.1 All steam locomotives of the actual TILLIG-Program, class V 60, VT 137, E 10.3, E 11/42	E-Lok BR 103 (Ausführungen vor Überarbeitung), Desiro, V 60.0, IC/IR-Steuerwagen Electric locomotive class 103 (previous versions), Desiro, V 60.0, IC/IR-driving cab coach	Überarbeitete Loks mit ehemals Bühler-Motor, BR 107, BR 189, sowie neue Elektro-/Dieselloks All revision locomotives with previous motor „Bühler“, class 107, class 189, new electric and diesel locomotives	BR 38, BR 110 class 38, class 110
66022 Decoder mit Kabel (Uhlenbrock)	x				
66021 Decoder mit Stecker (Uhlenbrock)		x		o	
66017 DCX74D (CT-Elektronik)			x	o	
66023 Decoder PluX12 (Uhlenbrock)				x außer BR 189 bis 2013 / excluding BR 198 till 2013; Loks mit Fernlicht / Loco with main beam	
66024 Decoder PluX12 (Uhlenbrock)				x Loks ohne Fernlicht / Loco without main beam	
66025 Decoder Next18 (Uhlenbrock)					x

Digital-Komponenten in Kooperation mit Uhlenbrock Elektronik GmbH
digital accessories in cooperation with Uhlenbrock Elektronik GmbH



Funktionsdecoder
decoder
(11 x 8 x 2,4)*

Art.-Nr: 66020 UVP in €: 27,90



Decoder mit Stecker
NEM 651 decoder to
connection via plugs
(14,9 x 8,6 x 2,4)*

Art.-Nr: 66021 UVP in €: 27,90



Decoder mit Kabel NEM 651
decoder to connection via
soldering
(14,9 x 8,6 x 2,4)*

Art.-Nr: 66022 UVP in €: 28,90

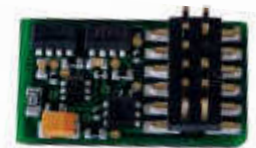

Decoder PluX 2 NEM 658
(für BR 189, TRAXX, Taurus)
Decoder PluX12, NEM 658
(14,7 x 8,6 x 2,4)*

Art.-Nr: 66023 UVP in €: 29,90



Decoder PluX12 NEM 658
(außer BR 189, TRAXX, Taurus)
Decoder PluX12, NEM 658
(14,7 x 8,6 x 2,4)*

Art.-Nr: 66024 UVP in €: 29,90



NEU
Decoder Next18 NEM 662
Decoder Next18, NEM 662
(14,7 x 8,6 x 2,4)*

Art.-Nr: 66025 UVP in €: 32,90

* Maßangaben (L x B x H) in Millimetern. /
Dimensions (l x b x h) in millimeters.

Schnittstelle nach NEM 651, Kontaktbelegung/Interface to NEM 651, contact assignment

Kontakt 1/contact 1: Motoranschluss 1/Engine connection 1	– orange/orange
Kontakt 2/contact 2: Motoranschluss 2/Engine connection 2	– grau/grey
Kontakt 3/contact 3: Stromabnahme, rechts/Electric current, right	– rot/red
Kontakt 4/contact 4: Stromabnahme, links – Masse/Electric current, left – mass	– schwarz/black
Kontakt 5/contact 5: Beleuchtung, vorn/Lighting, front side	– weiß/white
Kontakt 6/contact 6: Beleuchtung, hinten/Lighting, back side	– gelb/yellow

Hinweis / Note:

Bei der Diesellok V 100 und älteren TILLIG-Loks kann der Decoder 66022 eingelötet werden, siehe S. 190. / The decoder 66022 can solder in diesel locomotive class V 100 and older TILLIG locomotives, page 190.

PluX12 Pin	Name/Name	Farbe/Colour	Beschreibung/Description
7	F0f	weiß/white	Licht Fahrtrichtung vorwärts/Light when the direction of travel is forwards
8	Motor+	orange/orange	Motoranschluss Plus/Plus motor connection
9	V+	blau/blue	Decoder Plus, Abgriff nach Gleichrichter/Plus decoder, connector to rectifier
10	Motor-	grau/grey	Motoranschluss Minus/Minus motor connection
11	Index		Nicht benutzt, Kodierung/Not used, coding
12	Schiene rechts	rot/red	Schiene rechts in Fahrtrichtung vorwärts/Direction of travel is forwards when on the right track
13	F0r	gelb/yellow	Licht Fahrtrichtung rückwärts/Light when the direction of travel is backwards
14	Schiene links	schwarz/black	Schiene links in Fahrtrichtung vorwärts/Direction of travel is forwards when on the left track
15	LS/A		Lautsprecher Anschluss A/Loudspeaker connection A
16	AUX1	grün/green	Ausgang 1, Zugschlussbeleuchtung in Fahrtrichtung vorwärts Output 1, train rear lighting when direction of travel is forwards
17	LS/B		Lautsprecher Anschluss B/Loudspeaker connection B
18	AUX2	violett/purple	Ausgang 2, Zugschlussbeleuchtung in Fahrtrichtung rückwärts Output 2, train rear lighting when direction of travel is backwards

Erweiterte Funktionen der PluX12-Schnittstelle bei Einsatz eines PluX12-Decoders / Extended functions of the PluX12 interface when using a PluX12-Decoders:



z. B. je nach Modell

- Rote Schlusslichter separat ausschaltbar
- Rangierlicht: Spitzenlichter an beiden Seiten zugleich einschaltbar
- Fernlicht separat schaltbar

Weitere Informationen, auch zum Nachrüsten für Sound, entnehmen Sie bitte der jeweiligen Bedienungsanleitung der einzelnen Lokomotiven.

e. g. depending on model

- Red rear lights can be switched off separately
- Shunting light: Top lights at both sides can be switched on at the same time
- Long-distance light can be switched separately

Please gather further information, also regarding retrofitting for sound, from the respective operating instructions of the individual locomotives.

Kennzeichnung der Indizierung / Identification of indexing

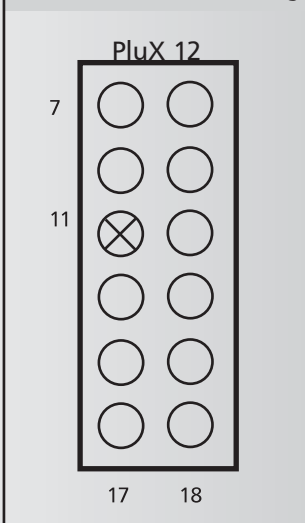

Digital-Komponenten in Kooperation mit Uhlenbrock Elektronik GmbH
digital accessories in cooperation with Uhlenbrock Elektronik GmbH



Schnittstellenstecker 6-polig
NEM 651 (5 Stück) für
Digitalisierung V36
insertation interface, NEM 651
for diesel loco class 36

Art.-Nr: 08914 UVP in €: 17,95



Kehrschleifenrelais
Reverse-loop relais

Art.-Nr: 66120 UVP in €: 19,90



Loconet Verteiler
Loconet distributor

Art.-Nr: 66588 UVP in €: 9,60



NEU

TILLIG Handregler DAISY II
TILLIG controller DAISY II

Art.-Nr: 66204 UVP in €: 149,00



NEU

Gleisbesetzmelder
Track detector

Art.-Nr: 66821 UVP in €: 25,90

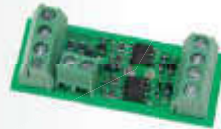

NEU

Polaritätstauscher
Polarity exchanger

Art.-Nr: 66824 UVP in €: 15,90



NEU

Booster Power 4
Booster power 4

Art.-Nr: 66825 UVP in €: 99,90



NEU

Magnetartikeldecoder
Magnet accessories decoder

Art.-Nr: 66835 UVP in €: 19,90



NEU

Schaltdecoder SD2
Switching decoder SD2

Art.-Nr: 66836 UVP in €: 25,95



NEU

Schaltdecoder SD1
Switching decoder SD1

Art.-Nr: 66837 UVP in €: 23,95



NEU

LocoNet Schaltmodul
LocoNet switching module

Art.-Nr: 66838 UVP in €: 74,90



NEU

USB-LocoNet Adapter
(mit Software)
USB-LocoNet adapter (with
software)

Art.-Nr: 66844 UVP in €: 89,00



Decoder Gold mini + zum Anschluss über Kabel
Gold mini + decoder to connection via soldering
(11 x 9 x 2,6)*

Art.-Nr: 66012 A UVP in €: 50,90



Decoder Silber mini + zum Anschluss über Kabel
Silver mini + decoder to connection via soldering
(11,5 x 7,5 x 2,6)*

Art.-Nr: 66014 A UVP in €: 43,50



Digitaldecoder CT Elektronik DCX74D, ermöglicht zusätzliche Lichtfunktion für VT137, V60.10-11, Desiro BR 642
Decoder CT Electronic CX74D, enables additional light functions VT137, V60.10-11, Rail car class 642
(13 x 9 x 1,5)*

Art.-Nr: 66017 UVP in €: 48,90

* Maßangaben (L x B x H) in Millimetern. / Dimensions (L x B x H) in millimeters.



Soundbaustein für BR 189 (Lautsprecher und Soundkapsel), ermöglicht beim Einsatz eines PluX12-Decoders im Digitalbetrieb (ehemals 66016 Tams) die Wiedergabe der Typhontöne der Lok

Sound module for BR 189 (loudspeaker and sound capsule) enables the reproduction of the locomotive's typhon tones when using a PluX12 decoder in the digital mode (formerly item no. 66016 Tams)

Art.-Nr: 66050 UVP in €: 17,50

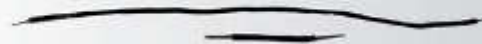

Soundbaustein für Dieselloks mit PluX12-Schnittstelle (BR 118, 119, 218, 220, NoHAB), ermöglicht beim Einsatz eines PluX12-Decoders im Digitalbetrieb (ehemals 66016 Tams) die Wiedergabe der Typhontöne der Lok

Sound module for modified diesel locomotives with PluX12 interface (BR 118, 119, 218, 220, NoHAB) enables the reproduction of the locomotive's typhon tones when using a PluX12 decoder in the digital mode (formerly item no. 66016 Tams)

Art.-Nr: 66051 UVP in €: 17,50

Unser Bettungs-Gleissystem – Der ideale Einstieg in die Welt der TT-Modelleisenbahn Our bedding track system – The best start into the world of modelrailways

Damit wird Ihnen der Aufbau einer Modellbahnanlage leicht gemacht wie noch nie. Durch das moderne Verbindungssystem „UniJoiner“® vereint es Funktionalität und Optik des bekannten TT-Modellgleises mit einer genial einfachen Montage. Das bereits integrierte Schotterbett gibt den Gleisen ein vorbildentsprechendes Aussehen und lässt z. B. die Weichenantriebe einfach „verschwinden“. Die Geometrie des Bettungsgleises ist so gewählt, dass volle Kompatibilität zum TT-Modellgleis besteht. So kann ganz leicht eine Modellbahnanlage aufgebaut werden – vom einfachen Gleisbild bis zum großzügig gestalteten Fahrbetrieb. Schritt für Schritt werden wir künftig dieses Gleissystem weiter ausbauen, so dass in Zukunft die Möglichkeiten der Gleisplanung noch vielfältiger werden.

With bedding track system the design of model railway is as simple as never before. The modern connector system „UniJoiner“ joins both in functionality and optical characteristics of the known TT-model track with very easy assembling. With the still integrated ballast bed tracks are true to the original and point mechanism seems to disappear. The bedding track geometry is absolutely compatible with TT-model track. So it is easy to design a model railway – from easy track diagram to extensive designed model railway. Step by step we will expand our track system so you get various possibilities for planning tracks.

„UniJoiner“® ist ein Warenzeichen von Kato.
„UniJoiner“ is a trade mark of Kato.



Die Vorteile auf einen Blick:

- Kinderleicht, stabil und robust
- Sichere Verbindung der Gleiselemente:
Ein „Klick“ – und fertig!
- Weichenantriebe sind nicht sichtbar
- Hervorragend geeignet für Gleisanlagen zum häufigen Auf- und Abbau sowie für Vitrinen
- Einsatz auf jedem Untergrund (Teppich, Tisch usw.) möglich
- Kompatibilität zum Modellgleis (unter Verwendung von Modellgleis-Schienenverbindern; dabei bitte den Höhenausgleich durch entsprechenden Unterbau des Modellgleises beachten)

Advantages at a glance:

- it is child's play to use, robust
- certain connection between track elements
one „click“ – and ready
- point mechanism is invisible
- eminent suited to set up and dismantle tracks often
- can be used for every underground
- compatible with TT-model track (using rail joiner of model track; please note to adapt the difference in height)

Gerade Gleise / Straight track



BG 1: Gerades Gleis, 166 mm
BG 1: Straight track, 166 mm

Art.-Nr: 83701	UVP in €: 2,25	grau
Art.-Nr: 83712	UVP in €: 2,25	braun



BG 2: Gerades Gleis, 83 mm
BG 2: Straight track, 83 mm

Art.-Nr: 83702	UVP in €: 2,15	grau
Art.-Nr: 83713	UVP in €: 2,15	braun

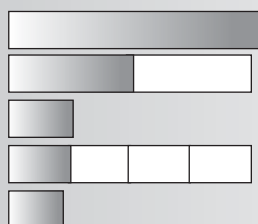

G 1 = 166,0 mm
G 2 = 83,0 mm
G 3 = 43,0 mm
G 4 = 41,5 mm
G 5 = 36,5 mm



BG 4: Gerades Gleis, 41,5 mm
BG 4: Straight track, 41,5 mm

Art.-Nr: 83703	UVP in €: 1,95	grau
Art.-Nr: 83715	UVP in €: 1,95	braun

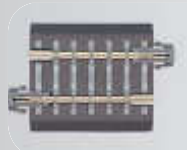

BG 5: Gerades Gleis, 36,5 mm
BG 5: Straight track, 36,5 mm

Art.-Nr: 83704	UVP in €: 1,95	grau
Art.-Nr: 83716	UVP in €: 1,95	braun



BG 3: Gerades Gleis, 43 mm
BG 3: Straight track, 43 mm

Art.-Nr: 83705	UVP in €: 2,05	grau
Art.-Nr: 83714	UVP in €: 2,05	braun

Gebogene Gleise / Curved track



BR 11: Gebogenes Gleis, R 310 mm/30°
BR 11: Curved track, R 310 mm/30°

Art.-Nr: 83709	UVP in €: 2,80	grau
Art.-Nr: 83719	UVP in €: 2,80	braun



BR 21: Gebogenes Gleis, R 353 mm/30°
BR 21: Curved track, R 353 mm/30°

Art.-Nr: 83706	UVP in €: 2,80	grau
Art.-Nr: 83717	UVP in €: 2,80	braun



BR 12: Gebogenes Gleis, R 310 mm/15°
BR 12: Curved track, R 310 mm/15°

Art.-Nr: 83710	UVP in €: 2,25	grau
Art.-Nr: 83720	UVP in €: 2,25	braun



BR 22: Gebogenes Gleis, R 353 mm/15°
BR 22: Curved track, R 353 mm/15°

Art.-Nr: 83707	UVP in €: 2,25	grau
Art.-Nr: 83718	UVP in €: 2,25	braun

Kreuzung / Crossing

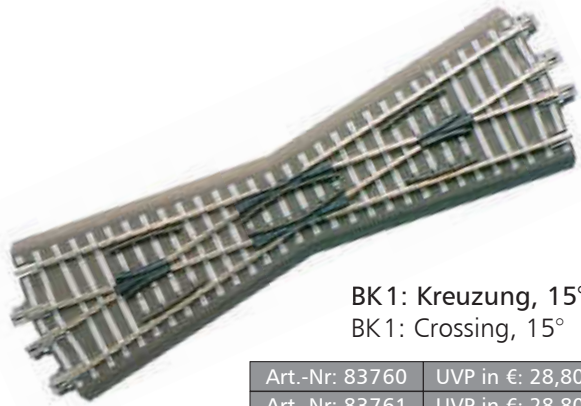

BK1: Kreuzung, 15°
BK1: Crossing, 15°

Art.-Nr: 83760	UVP in €: 28,80	grau
Art.-Nr: 83761	UVP in €: 28,80	braun

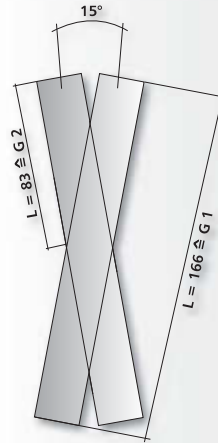

Einfache Weichen
Straight points

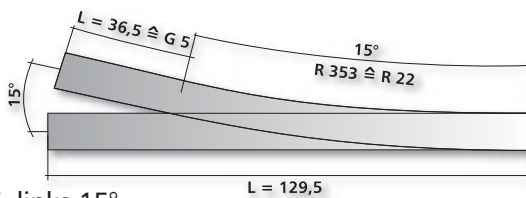

BW, links 15°,
mit Handantrieb
BW, left, 15°
with hand drive

Art.-Nr: 83817	UVP in €: 16,60	grau
Art.-Nr: 83821	UVP in €: 16,60	braun

BW, rechts 15°,
mit Handantrieb
BW, right, 15°
with hand drive

Art.-Nr: 83816	UVP in €: 16,60	grau
Art.-Nr: 83820	UVP in €: 16,60	braun

Innenbogenweichen
Inside curved points

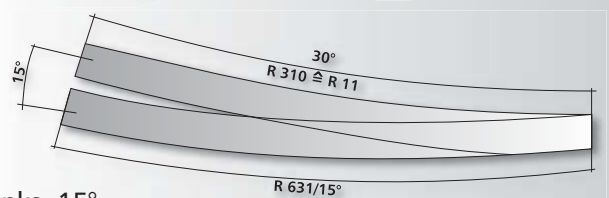

IBW, links 15°,
mit Handantrieb
IBW, left, 15°
with hand drive

Art.-Nr: 83862	UVP in €: 21,10	grau
Art.-Nr: 83864	UVP in €: 21,10	braun

IBW, rechts 15°,
mit Handantrieb
IBW, right, 15°
with hand drive

Art.-Nr: 83861	UVP in €: 21,10	grau
Art.-Nr: 83863	UVP in €: 21,10	braun

Pass-Stücke / Compatible units

Die Pass-Stücke haben jeweils eine Aussparung in der Bettung auf der rechten bzw. linken Seite. Ein Pass-Stück wird an einem der beiden abzweigenden Gleise direkt hinter der Weiche benötigt.

The compatible units have a cut-out in bedding on the right/left side. A compatible unit is required at one of the two branched tracks directly behind the points.

Hinweis / Note:

Im Bedarfsfall sind die werksseitig angebrachten Schienenverbinder zu entfernen bzw. umzustecken. / You can remove or change the position of the rail joiners which are mounted by the factory.



BR 12-22kre: Gebogenes Pass-Stück, rechts,
R 310 – 353 mm/15°
BR 12-22kre: Curved compatible unit, right,
R 310 – 353 mm/15°

Art.-Nr. 83725	UVP in €: 2,25	grau
Art.-Nr. 83731	UVP in €: 2,25	braun



BR 22kre: Gebogenes Pass-Stück, rechts,
R 353 mm/15°
BR 22kre: Curved compatible unit, right, R
353 mm/15°

Art.-Nr. 83723	UVP in €: 2,25	grau
Art.-Nr. 83729	UVP in €: 2,25	braun



BR 22kli: Gebogenes Pass-Stück, links,
R 353 mm/15°
BR 22kli: Curved compatible unit, left, R 353 mm/15°

Art.-Nr. 83724	UVP in €: 2,25	grau
Art.-Nr. 83730	UVP in €: 2,25	braun



BR 12-22kli: Gebogenes Pass-Stück, links,
R 310 – 353 mm/15°
BR 12-22kli: Curved compatible unit, left,
R 310 – 353 mm/15°

Art.-Nr. 83726	UVP in €: 2,25	grau
Art.-Nr. 83732	UVP in €: 2,25	braun



BG 5: Pass-Stück, kre
BG 5: Compatible unit, kre

Art.-Nr. 83721	UVP in €: 1,30	grau
Art.-Nr. 83727	UVP in €: 1,30	braun



BG 5: Pass-Stück, kli
BG 5: Compatible unit, kli

Art.-Nr. 83722	UVP in €: 1,30	grau
Art.-Nr. 83728	UVP in €: 1,30	braun



Foto: H. Liedtke

Entkupplungsgleis / Uncoupling track

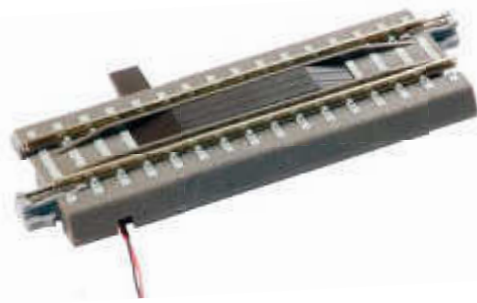

Entkupplungsgleis, 83 mm, elektromotorisch
Uncoupling track, 83 mm, electromotive

Art.-Nr: 83801	UVP in €: 29,90	grau
Art.-Nr: 83802	UVP in €: 29,90	braun



Schaltgleis, 83 mm
(geeignet für Pendelzugsteuerung mit TFi2)
Switching track 83 mm
(for automated shuttle train control by TFi2)

Art.-Nr: 83758	UVP in €: 10,50	grau
Art.-Nr: 83759	UVP in €: 10,50	braun

Gleiszubehör / Track accessories

Halbe Schienenverbinder für Bettungsweiche
Half rail joiners for roadbed points

Art.-Nr: 396942	UVP in €: 0,60	grau
Art.-Nr: 396943	UVP in €: 0,60	braun

Isolierschienenverbinder (Beutel à 20 Stück)
Isolated rail joiners (bag of 20)

Art.-Nr: 83952	UVP in €: 3,85	grau
Art.-Nr: 83955	UVP in €: 3,85	braun

Bettungsgleis-Schienenverbinder (Beutel à 20 Stück)
Bedding track rail joiners (bag of 20)

Art.-Nr: 83950	UVP in €: 7,05	grau
Art.-Nr: 83953	UVP in €: 7,05	braun

Schienenverbinder mit Anschlusselement
(Beutel à 10 Stück)

Rail joiners with connector

Art.-Nr: 83951	UVP in €: 8,25	grau
Art.-Nr: 83954	UVP in €: 8,25	braun

Schotterabschluss (Beutel à 4 Stück)
Gravel terminal (bag of 4)

Art.-Nr: 83961	UVP in €: 3,40	grau
Art.-Nr: 83963	UVP in €: 3,40	braun



Prellbock mit Gleisstück 43 mm
Buffer stop with track 43 mm



Art.-Nr: 83700	UVP in €: 6,20	grau
Art.-Nr: 83711	UVP in €: 6,20	braun

BA 1: Gerades Anschlussgleis mit Entstörkondensator, 166 mm (für Analogbetrieb, bei Digitalbetrieb Entstörkondensator entfernen), Anschlusskabel mit Kabelsteckhülsen unter der Bettung steckbar.

BA 1: Sidings with anti-interference capacitors, 166 mm (for analogue operation, remove the anti-interference capacitor during digital operation), power cable that can be connected with the cable push-on contact under the roadbeds.

Art.-Nr: 83740 (ohne Abb.)	UVP in €: 5,15	grau
Art.-Nr: 83741 (ohne Abb.)	UVP in €: 5,15	braun

Mini-Holzschrauben, zur Befestigung von Bettungs-Gleismaterial 1,4 x 15 mm (Beutel à 100 Stück)

Mini wooden screws for the attachment of roadbed track material 1.4 x 15 mm (bag of 100)



Art.-Nr: 08976	UVP in €: 9,70
----------------	----------------

Elektrischer Weichenantrieb, zum Nachrüsten der Handweichen, Art. 83816/817, 83861/862

Electric point mechanism, for the retrofitting of the manual points, product no. 83816/817, 83861/862



Art.-Nr: 83960	UVP in €: 16,60
----------------	-----------------

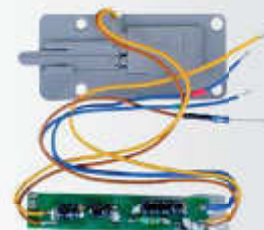

Motorischer Weichenantrieb für Bettungsgleis-Weichen
Point-motor for TILLIG-bedding-track points

Art.-Nr.: 08331	UVP in €: 36,30
-----------------	-----------------

Beispiele für mögliche Gleisentwicklungen / Examples of possible track developments

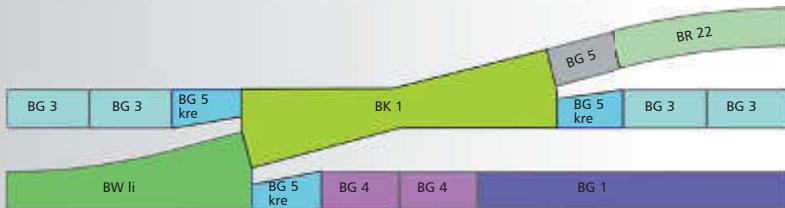
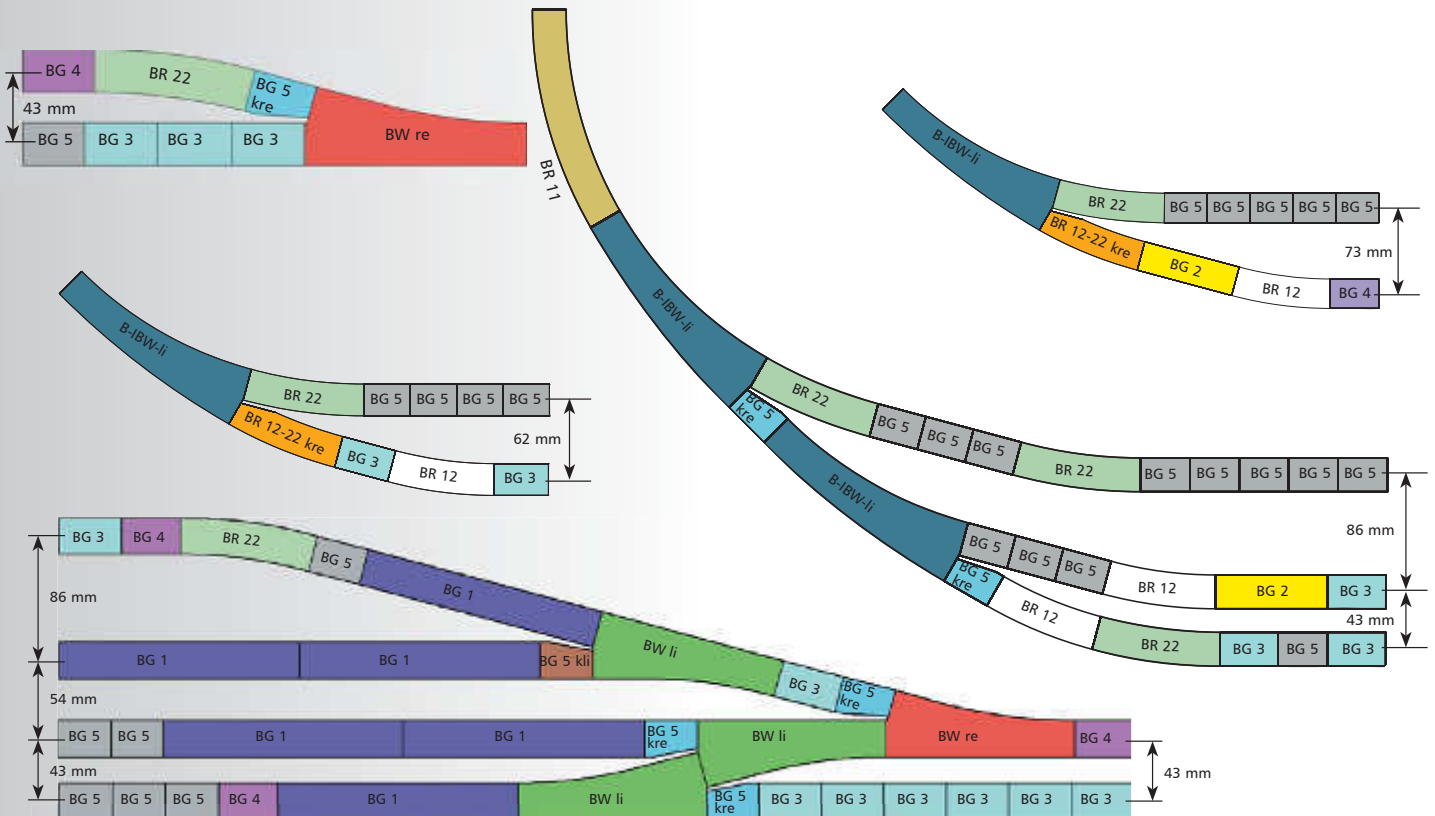

Legende / legend:

	grau / braun
BG 1	Art.-Nr: 83701 / 83712
BG 2	Art.-Nr: 83702 / 83713
BG 3	Art.-Nr: 83705 / 83714
BG 4	Art.-Nr: 83703 / 83715
BG 5	Art.-Nr: 83704 / 83716
BG 5 kre	Art.-Nr: 83721 / 83727
BG 5 kli	Art.-Nr: 83722 / 83728
BR 11	Art.-Nr: 83709 / 83719
BR 12	Art.-Nr: 83710 / 83720
BR 21	Art.-Nr: 83706 / 83717
BR 22	Art.-Nr: 83707 / 83718
BR 12-22 kre	Art.-Nr: 83725 / 83731
BR 12-22 kli	Art.-Nr: 83726 / 83732
BR 22 kre	Art.-Nr: 83723 / 83729
BR 22 kli	Art.-Nr: 83724 / 83730
BW re	Art.-Nr: 83816 / 83820
BW li	Art.-Nr: 83817 / 83821
B-IBW re	Art.-Nr: 83861 / 83863
B-IBW li	Art.-Nr: 83862 / 83864
BK 1	Art.-Nr: 83760 / 83761

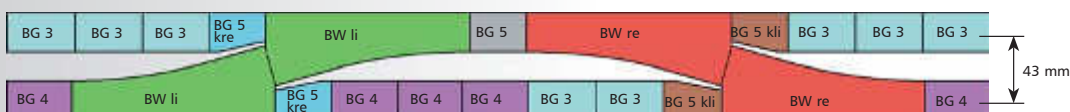
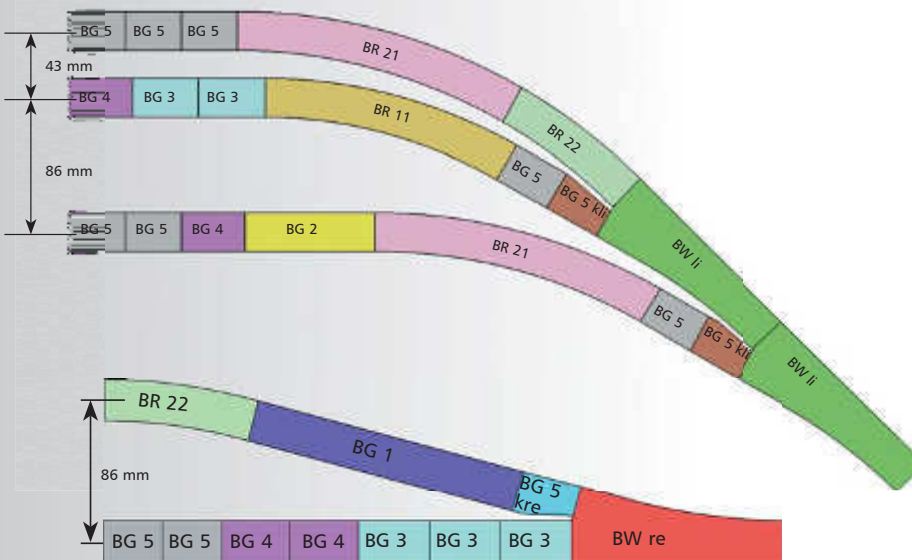

Beispiele für mögliche Gleisentwicklungen / Examples of possible track developments

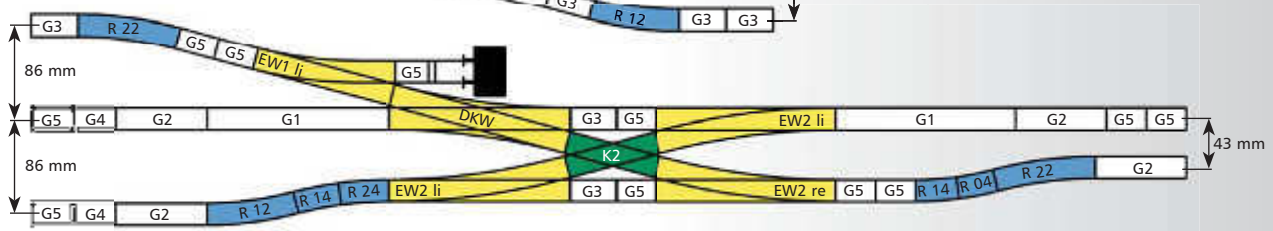
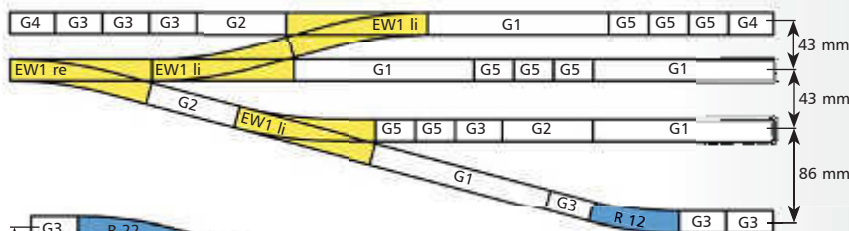
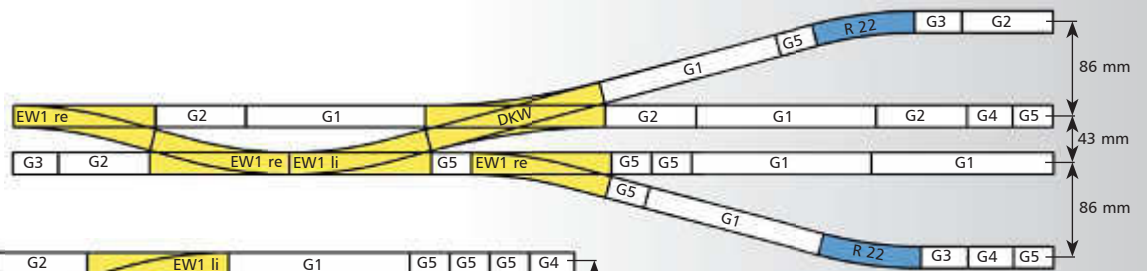

Legende / legend:

G1	Art.-Nr: 83101
G2	Art.-Nr: 83102
G3	Art.-Nr: 83105
G4	Art.-Nr: 83103
G5	Art.-Nr: 83104
G6	Art.-Nr: 83120
R 01	Art.-Nr: 83116
R 04	Art.-Nr: 83115
R 11	Art.-Nr: 83109
R 12	Art.-Nr: 83110
R 14	Art.-Nr: 83113
R 21	Art.-Nr: 83106
R 22	Art.-Nr: 83107
R 24	Art.-Nr: 83116
R 31	Art.-Nr: 83111
R 32	Art.-Nr: 83112
K1	Art.-Nr: 83161
K2	Art.-Nr: 83170
DKW	Art.-Nr: 83300
DKW II	Art.-Nr: 83391
DGV	Art.-Nr: 83210

EW1 re	Art.-Nr: 83321
EW1 li	Art.-Nr: 83322
EW2 re	Art.-Nr: 83331
EW2 li	Art.-Nr: 83332
EW3 li	Art.-Nr: 83332
IBW re	Art.-Nr: 83342
IBW li	Art.-Nr: 83361
Flexgleis	Art.-Nr: 83362
	Art.-Nr: 83125

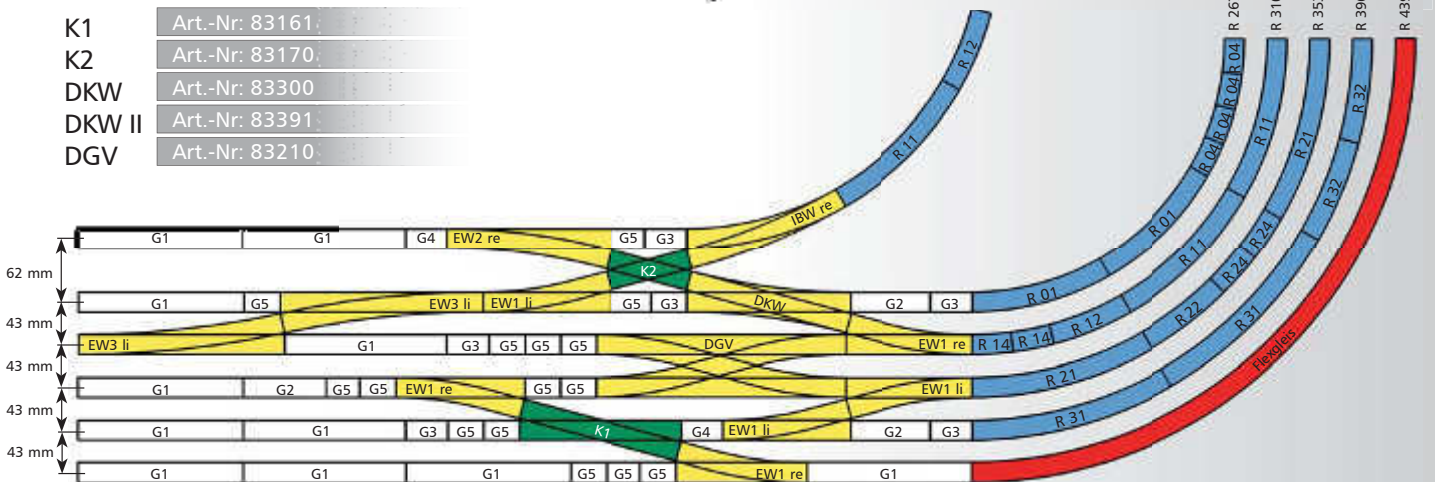
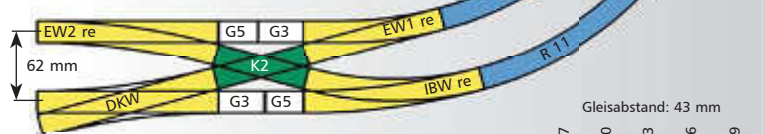

Das TT-Modellgleissystem / The Advanced track system

Unser TT-Modell-Gleissystem mit 2,07 mm hohen Schienenprofilen aus Neusilber entspricht den heutigen hohen Qualitätsansprüchen an ein modernes Modellbahn-Gleis. Es lehnt sich im Äußeren stark an das Vorbild an. Für den anspruchsvollen Gleisbau stehen Ihnen neben blanken auch brünierte Schienenprofile zur Verfügung, die ein vorbildnahes Erscheinungsbild ergeben.

Für den Bau Ihrer Weichenstraßen können Sie zwischen Weichen verschiedener Herzstückwinkel wählen, von platzsparenden 15°-Weichen bis hin zu eleganten schlanken Weichen mit einem Herzstückwinkel von 12° und federnden Weichenzungen. Neben einfachen Weichen erhalten Sie zahlreiche weitere Formen wie Innenbo-

gen-, Außenbogen- und Doppelkreuzungsweichen, doppelte Gleisverbindungen oder ganz neu: Unsere Dreiwegeweiche. Zusätzlich zu den angebotenen Gleisradien lässt sich jeder beliebige Radius mit Flexgleis realisieren. Hier ist für den ernsthaften Modellbahner die Auswahl verschiedener Schwellenarten möglich: Die allgemein übliche Holzschwelle, eine Stahlschwelle, die in der Epoche II weitläufig eingeführt war und bis zum Einsatz der dritten angebotenen Schwellenart, der Betonschwelle, im Gleisbau eingesetzt wurde. Somit ist mit unserem Modell-Gleissystem ein umfassendes Angebot gegeben, um eine dem Vorbild entsprechende Strecke aufzubauen. Dem Individualisten werden fast alle Gleiselemente auch als Bausatz angeboten. Da bei diesen aufwändiges Löten, Kleben und Profilageln entfällt, geht der Selbstbau schnell und problemlos von der Hand. Diese Art der Gleisverlegung gestattet bei Verwendung von Flexstegweichen-Bausätzen (Art. 83420, 83421) eine sehr individuelle Gleisgeometrie und ist darüber hinaus auch preisbewusst.

Ergänzt wird unser Modell-Gleissystem schließlich durch unsere STYROSTONE®-Gleisbettung mit echtem Schottermaterial. Durch diese erhalten die Gleise auf schnelle und einfache Art ein Schotterbett, ohne dass ein aufwendiges Einschottern per Hand notwendig wird.

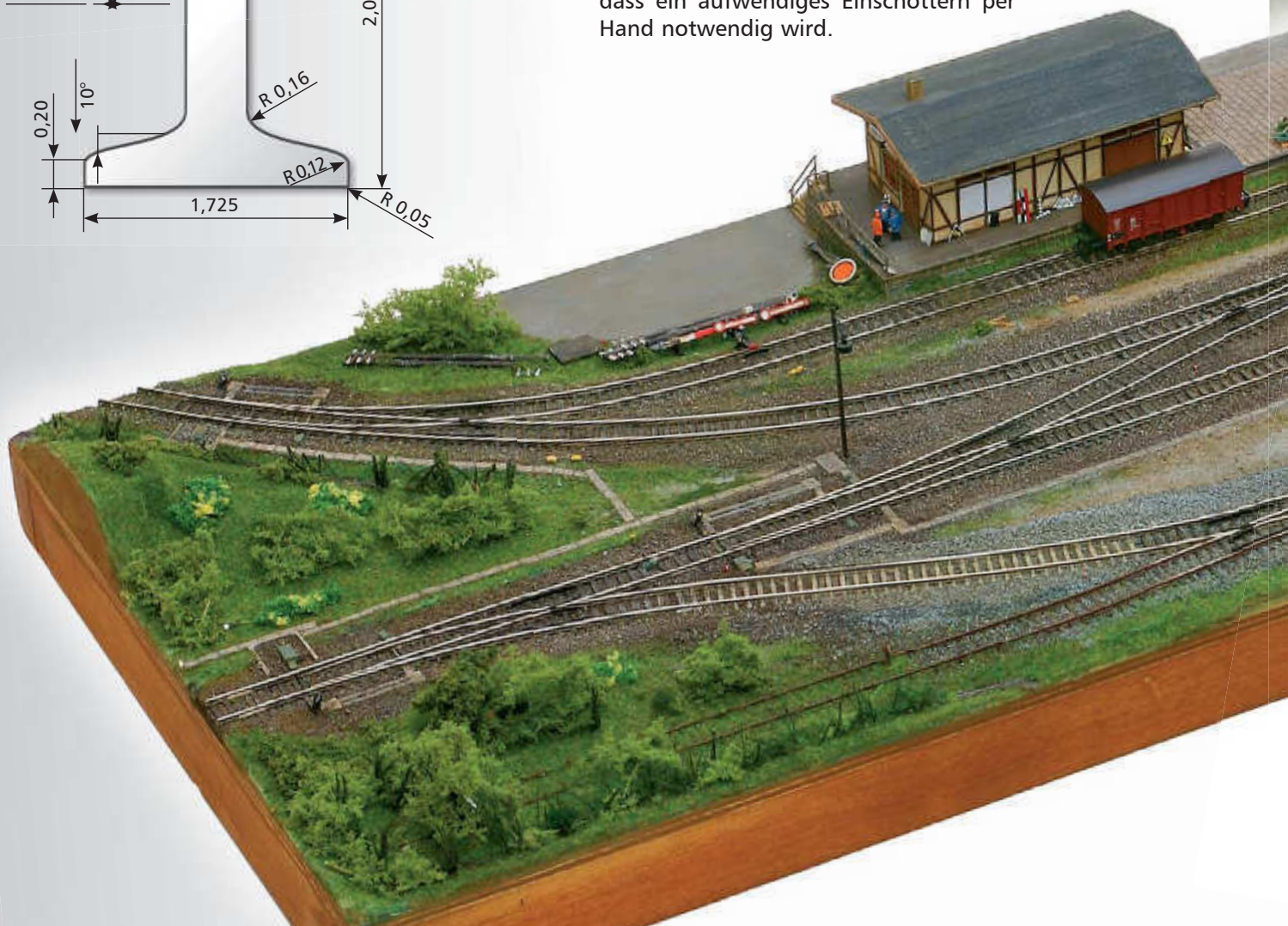
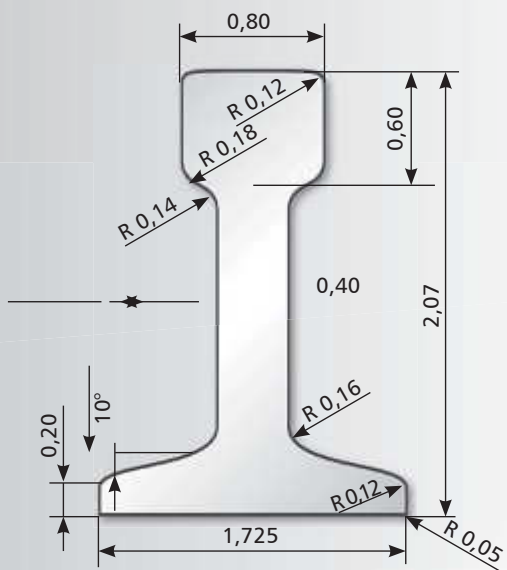

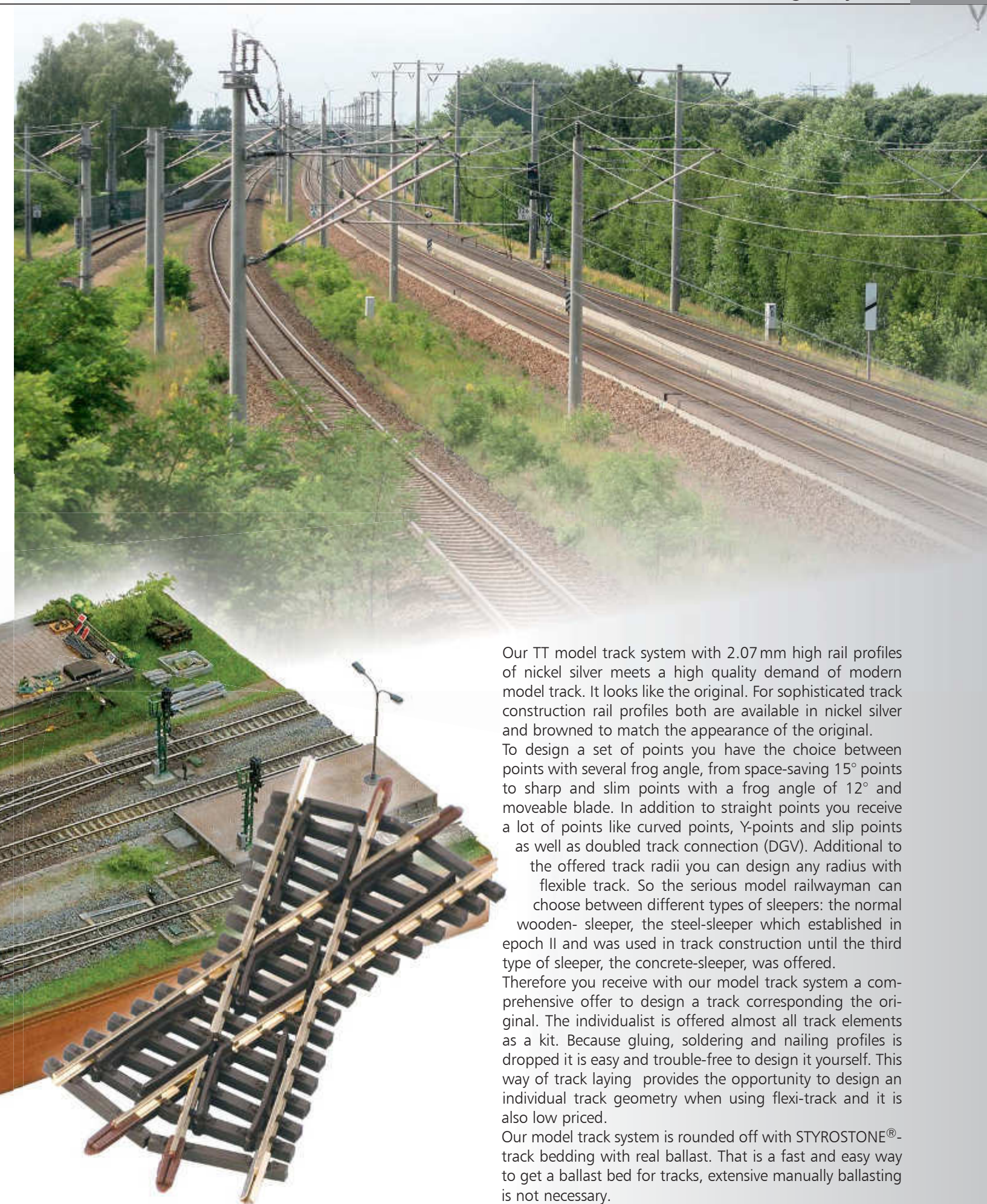

Our TT model track system with 2.07 mm high rail profiles of nickel silver meets a high quality demand of modern model track. It looks like the original. For sophisticated track construction rail profiles both are available in nickel silver and browned to match the appearance of the original.

To design a set of points you have the choice between points with several frog angle, from space-saving 15° points to sharp and slim points with a frog angle of 12° and moveable blade. In addition to straight points you receive a lot of points like curved points, Y-points and slip points as well as doubled track connection (DGV). Additional to

the offered track radii you can design any radius with flexible track. So the serious model railwayman can choose between different types of sleepers: the normal wooden-sleeper, the steel-sleeper which established in epoch II and was used in track construction until the third type of sleeper, the concrete-sleeper, was offered.

Therefore you receive with our model track system a comprehensive offer to design a track corresponding the original. The individualist is offered almost all track elements as a kit. Because gluing, soldering and nailing profiles is dropped it is easy and trouble-free to design it yourself. This way of track laying provides the opportunity to design an individual track geometry when using flexi-track and it is also low priced.

Our model track system is rounded off with STYROSTONE®-track bedding with real ballast. That is a fast and easy way to get a ballast bed for tracks, extensive manually ballasting is not necessary.

Gerade Gleise / Straight tracks



G1: Gerades Gleis, 166 mm
G1: Straight track, 166 mm

Art.-Nr: 83101 UVP in €: 1,90

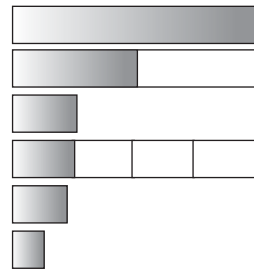

- G1 = 166,0 mm
- G2 = 83,0 mm
- G3 = 43,0 mm
- G4 = 41,5 mm
- G5 = 36,5 mm
- G6 = 21,3 mm



G2: Gerades Gleis, 83 mm
G2: Straight track, 83 mm

Art.-Nr: 83102 UVP in €: 1,90



G3: Gerades Gleis, 43 mm
G3: Straight track, 43 mm

Art.-Nr: 83105 UVP in €: 1,90



G4: Gerades Gleis, 41,5 mm
G4: Straight track, 41,5 mm

Art.-Nr: 83103 UVP in €: 1,90



G5: Gerades Gleis, 36,5 mm
G5: Straight track, 36,5 mm

Art.-Nr: 83104 UVP in €: 1,90



G6: Gerades Gleis, 21,3 mm
G6: Straight track, 21,3 mm

Art.-Nr: 83120 UVP in €: 1,90



Übergangsgleis: Standardgleis/Modellgleis, 57 mm
Adapter track: Standard-/Advanced track system, 57 mm

Art.-Nr: 83132 UVP in €: 2,45

Modulausgleichsstück, Länge 83,0 mm – 88,0 mm
Module linking track, Length 83,0 mm – 88,0 mm

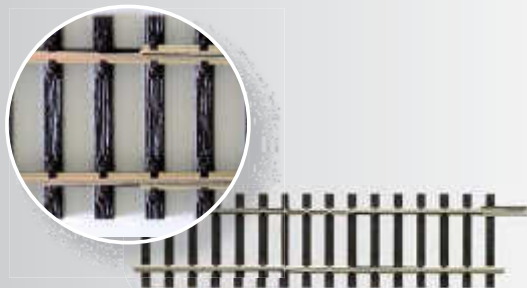

Art.-Nr: 83139 UVP in €: 3,85

Modulausgleichsstück:
Dieses Gleisstück besitzt verschiebbare Schienenprofile, so dass am Plattenrand eingebaut, diese die Lücke zum benachbarten Anlagenteil durch Herausziehen überbrücken können. Andererseits können sie für den sicheren Transport der Anlagenteile hinter die Plattenkante zurückgeschoben werden. Hiermit ist ein Ausgleich von ca. 3 mm möglich.

Bausatz vier Prellböcke
kit with four buffer stops



Art.-Nr: 83442 UVP in €: 12,00 gelb / yellow
Art.-Nr: 83441 UVP in €: 12,00 grau / grey



Prellbock mit Gleisstück
41,5 mm
Buffer stop with track
41,5 mm

Art.-Nr: 83100 UVP in €: 6,20



Prellbock ohne Gleisstück
Buffer stop without track

Art.-Nr: 07950 UVP in €: 4,50

Module linking track:
The rail profiles of this track element are designed to remain variable in length, so that, when installed at the edge of a layout board, the profiles can slide out to bridge the gap to a neighbouring layout module. Equally important, the profiles can be pushed back from the board edge to permit safe transportation of the individual layout sections.

Gebogene Gleise / Curved tracks



R11: Gebogenes Gleis, R 310 mm/30°
R11: Curved track, R 310 mm/30°

Art.-Nr: 83109
UVP in €: 2,35

R12: Gebogenes Gleis, R 310 mm/15°
R12: Curved track, R 310 mm/15°

Art.-Nr: 83110
UVP in €: 2,10

R14: Gebogenes Gleis, R 310 mm/7,5°
R14: Curved track, R 310 mm/7,5°

Art.-Nr: 83113
UVP in €: 2,10



R21: Gebogenes Gleis, R 353 mm/30°
R21: Curved track, R 353 mm/30°

Art.-Nr: 83106
UVP in €: 2,35

R22: Gebogenes Gleis, R 353 mm/15°
R22: Curved track, R 353 mm/15°

Art.-Nr: 83107
UVP in €: 2,10

R24: Gebogenes Gleis, R 353 mm/7,5°
R24: Curved track, R 353 mm/7,5°

Art.-Nr: 83114
UVP in €: 2,10

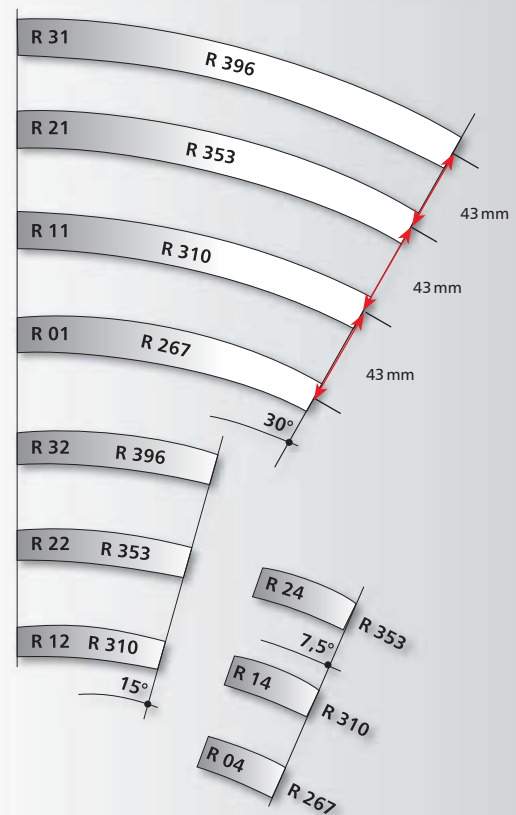

R31: Gebogenes Gleis, R 396 mm/30°
R31: Curved track, R 396 mm/30°

Art.-Nr: 83111
UVP in €: 2,35

R32: Gebogenes Gleis, R 396 mm/15°
R32: Curved track, R 396 mm/15°

Art.-Nr: 83112
UVP in €: 2,10



R01: Gebogenes Gleis, R 267 mm/30°
R01: Curved track, R 267 mm/30°

Art.-Nr: 83116
UVP in €: 2,35

R04: Gebogenes Gleis, R 267 mm/7,5°
R04: Curved track, R 267 mm/7,5°

Art.-Nr: 83115
UVP in €: 2,10

Achtung! Der Radius R 01/R 04 ist nur für Industriegleise und dem Einsatz von kurzen 2-achsigen Fahrzeugen geeignet!

Attention! The R 01/R 04 radius is appropriate for industrial tracks and the use of short 2 axle vehicles!

Flexgleise / Flexible Tracks

Holzschwellenflexgleis,
Länge ca. 664 mm
Wooden-sleeper flexi-track,
Length approx. 664 mm

Art.-Nr: 83125 UVP in €: 6,20

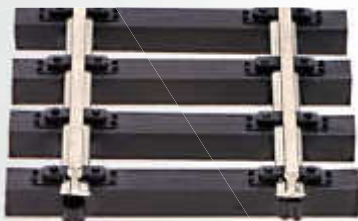

Stahlschwellenflexgleis,
Länge ca. 520 mm
Steel-sleeper flexi-track,
Length approx. 520 mm

Art.-Nr: 83136 UVP in €: 5,60



Betonschwellenflexgleis,
Länge ca. 520 mm
Concrete-sleeper flexi-track,
Length approx. 520 mm

Art.-Nr: 83134 UVP in €: 5,60



Hinweis/Note: Flexgleise werden ohne Schienenverbinder geliefert. / Flexible tracks are delivered without rail joiners.

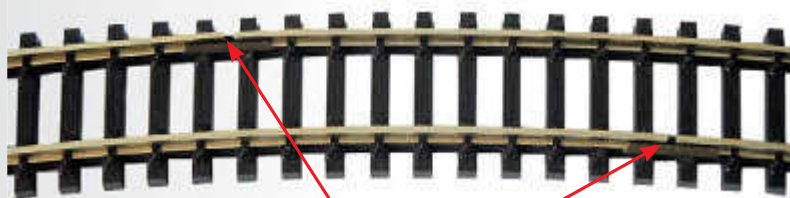

Beim Verlegen von Flexgleis im Gleisbogen sollten die Stoßstellen der Profile versetzt eingebaut werden! Damit werden Knicke im Gleisbogen vermieden.

The profile joints should be staggered when laying flexi-track for track curves! This helps to prevent kinking in the curve.

Flexgleise / Flexible Tracks

- Für individuelle Radien und großzügige Gleisbögen
- Realistischer Gleisoberbau durch drei verschiedene Schwellenarten
- Kombination verschiedener Schwellenarten ist durchaus vorbildtypisch (z. B. Streckengleis – Betonschwelle, Brücken und Weichen – Holzschwelle)
- Used anywhere where individual radii are required or perhaps when a more spacious situation is available
- TILLIG offers three kinds of sleepers
- A combination of different sleeper materials is not unusual, offers close to the original many situations (sleeper track on modern routes and for instance wooden sleepers on girder bridges)

Das Modellgleis-Weichensystem / The advanced track points system

Großzügigkeit und vorbildnahe Aussehen werden die Modellgleis-Weichen mit einem Herzstückwinkel von 12° gerecht. Oft steht dem Modellbahner allerdings weniger Platz zur Verfügung, so dass für den Aufbau der interessanten, aber meist umfangreichen Nebengleisanlagen der Bahnhöfe auch kürzere 15°-Weichen angeboten werden. Die schlankeren Weichen EW 2 und EW 3 sowie unsere ABW, Flexsteg-Bogenweichen und die neuen Baeseler-DKW überzeugen durch ihre vorbildgetreue Nachbildung ohne störende Gelenke (federnde Weichenzungen) und Herzstücken aus gefrästen Profilstücken statt aus Kunststoff bestehend. Neben dem Einsatz der TILLIG-Oberflur-Antriebe (passend für EW 1, Dreiwegeweiche, Innenbogen- und Doppelkreuzungsweichen I) können sämtliche Weichen mit unserem motorischen Unterflurtrieb geschaltet werden, was dem vorbildgetreuen Aussehen Ihrer Gleisanlagen einen weiteren Pluspunkt verschafft.

The model track points with a core angle of 12° are extensive and have an exemplary appearance. However, model railway enthusiasts often do not have that much space at their disposal so shorter 15° points are also offered for the construction of the interesting, but frequently extensive siding sections of the railway stations. The narrower EW 2 and EW 3 points as well as our ABW (outer curve point) Flexsteg curved points and the new Baeseler crossing switch convince through their reproduction that is very faithful to the prototype without disruptive joints (spring loaded switch points) and cores that consist of countersunk moulding members rather than plastic. In addition to the employment of TILLIG surface-mounted drives (appropriate for the standard mark 1 type – EW 1, Three-way points, inner bend points and double crossing points I) all the points can be switched with our motorised underfloor mounted drive which additionally benefits the appearance of your track system in line with the prototype.

Feingefräste Weichenzunge
Precision-milled switch point

Stabiles Vollprofil mit 2,07 mm Höhe
Sturdy profile that is 2.07 mm in height

Herzstück aus gefrästen Profilstücken (bei EW 2, EW 3, ABW, Flexsteg-Weichen und DKW Baeseler) / Core made of countersunk moulding members (in the case of EW 2, EW 3, ABW (outer curve point), Flexsteg points and Baeseler double junction points)

Schienenkopfbreite 0,8 mm
Rail head width 0.8 mm

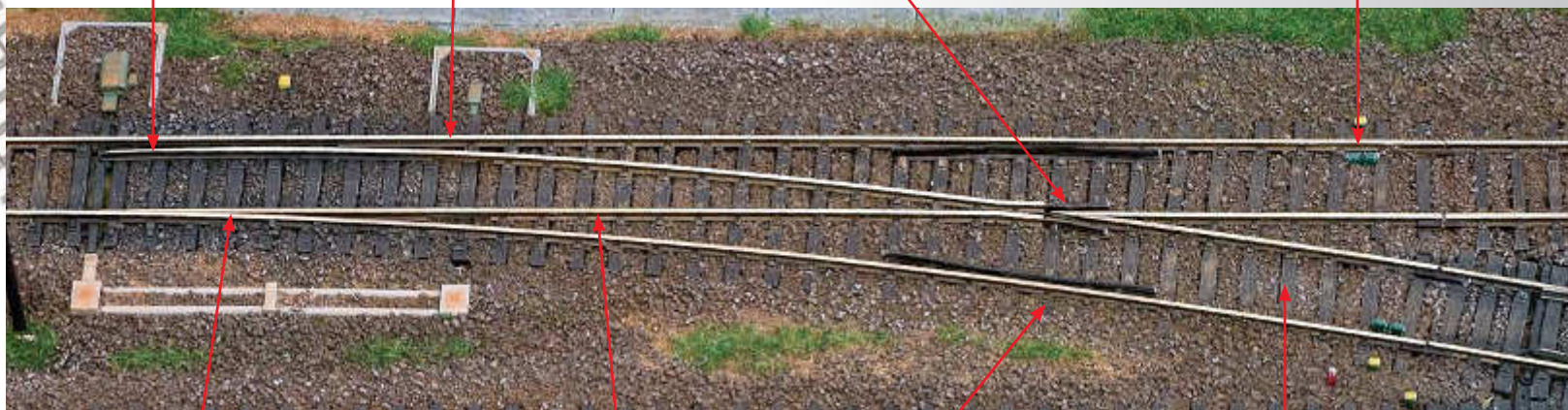

Neben blankem Schienenprofil auch eingefärbtes Profil (brüniert) erhältlich
It can also be obtained with a coloured profile (burnished) in addition to the bright rail profile

Durchgehende, federnde Weichenzungen (bei EW 2, EW 3, ABW, Flexsteg-Weichen und DKW Baeseler)
Constant, springy switch points (in the case of EW 2, EW 3, ABW (outer curve), Flexsteg points and Baeseler double junction points)

Vorbildgetreue Kleisenen-Nachbildung
Faithful reproduction of track fastenings

Holzschwellen mit fein detaillierter Holzmaserung
Wooden sleeper with very detailed wood grain

Hinweis / Note:

Im Bedarfsfall sind die werksseitig angebrachten Schienenverbinder zu entfernen bzw. umzustecken. / You can remove or change the position of the rail joiners which are mounted by the factory.

Einfache Weichen / Straight points

Achtung! Alle Weichen werden ohne Antriebe geliefert.

Attention! All the points are delivered without drives.

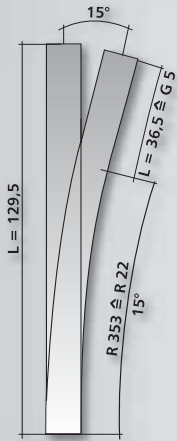

EW 1, links 15°, 129,5 mm
EW 1, left points 15°, 129,5 mm

EW 1, rechts 15°, 129,5 mm
EW 1, right points 15°, 129,5 mm

Art.-Nr: 83322
UVP in €: 14,20

Art.-Nr: 83321
UVP in €: 14,20

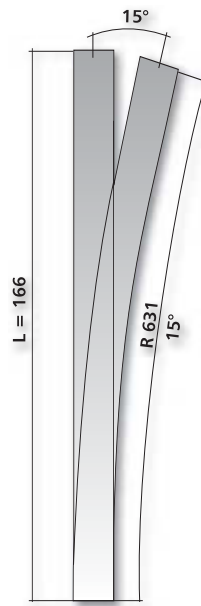

EW 2, links 15°, 166 mm
EW 2, left points 15°, 166 mm

EW 2, rechts 15°, 166 mm
EW 2, right points 15°, 166 mm

Art.-Nr: 83332
UVP in €: 19,50

Art.-Nr: 83331
UVP in €: 19,50

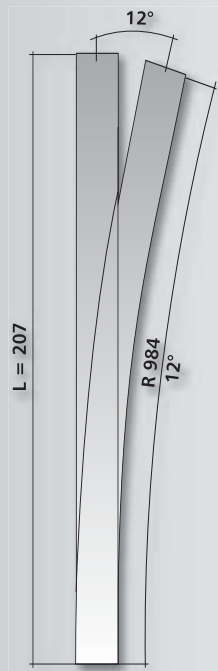

EW 3, links 12°, 207 mm
EW 3, left points 12°, 207 mm

EW 3, rechts 12°, 207 mm
EW 3, right points 12°, 207 mm

Art.-Nr: 83342
UVP in €: 20,50

Art.-Nr: 83341
UVP in €: 20,50

Innenbogenweichen / Inside curved points

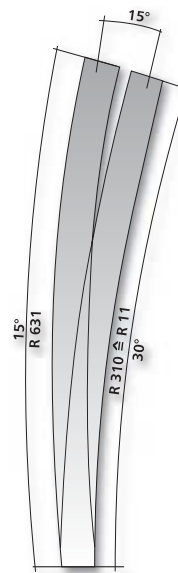

IBW, links
IBW, left points

IBW, rechts
IBW, right points

Art.-Nr: 83362
UVP in €: 14,80

Art.-Nr: 83361
UVP in €: 14,80

Außenbogenweichen /
Contrary flexure turnout

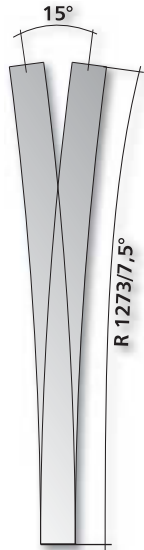

ABW, 15° (2 x 7,5°)
symmetrisch / symmetrical
Art.-Nr. 83380
UVP in €: 16,90

Dreiwege-Weichen / Three-way points
Zur Herzstückpolarisation kann der Schaltrelais-Baustein
Art.-Nr. 08414 (S. 226) verwendet werden.

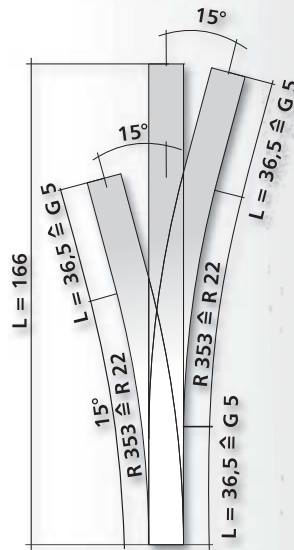

DWW, 2 x 15°, 166 mm
asymmetrisch / asymmetrical
Art.-Nr. 83230
UVP in €: 48,90

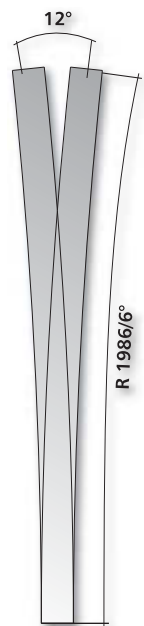

ABW, 12° (2 x 6°)
symmetrisch / symmetrical
Art.-Nr. 83382
UVP in €: 16,90

Passende Antriebe/Suitable operating gear

Art.-Nr.	Bezeichnung	83531 – elektr. Weichenantrieb/ Electric opera- ting gear	83532 – elektr. Weichenantrieb/ Electric opera- ting gear	86112 – Unterflur-Motor- Weichenantrieb/ Undermounted points operating motor
		83533 – Hand- Weichenantrieb/ Manual opera- ting gear	83534 – Hand- Weichenantrieb/ Manual opera- ting gear	
83321	EW 1	x		x
83322			x	x
83331	EW 2			x
83332				x
83341	EW 3			x
83342				x
83380	ABW 1			x
83382	ABW 2			x
83361	IBW	x		x
83362			x	x
83300	DKW 1	2 x	oder	2 x
83210	DGV	2 x	und 2 x	oder 4 x
83391	DKW 2			2 x
83230	Dreiwege- Weiche	x	und x	oder 2 x

Kreuzungen und Kreuzungswweichen / Crossings and slip points

Hinweis/Note:
 Passende Antriebe,
 Seite 215.
 Suitable operating gear,
 page 215.



K 1, 15°
 K 1, 15°



Art.-Nr: 83161
 UVP in €: 16,50

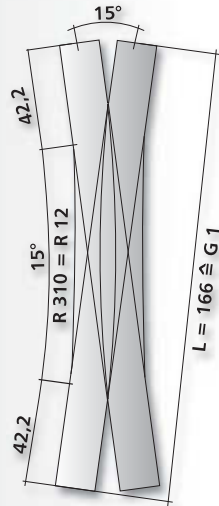

DKW 1
 DKW 1

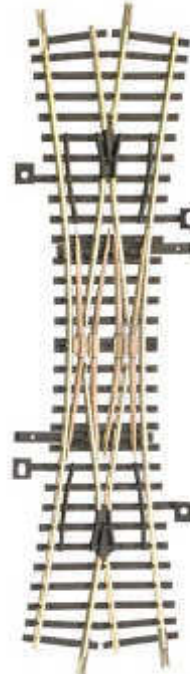

Art.-Nr: 83300
 UVP in €: 36,90

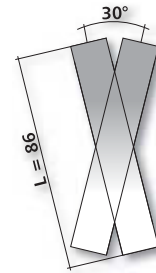

K 2, 30°
 K 2, 30°

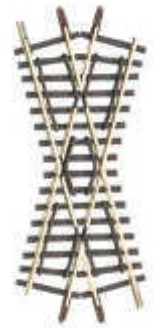

Art.-Nr: 83170
 UVP in €: 16,90

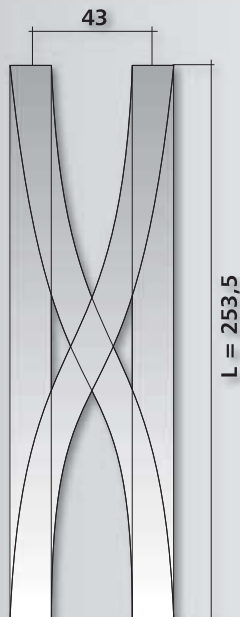

DGV 30°, Herzstückwinkel Weichen 15°
 DGV 30°, frog angle 15 °



Art.-Nr: 83210
 UVP in €: 95,90

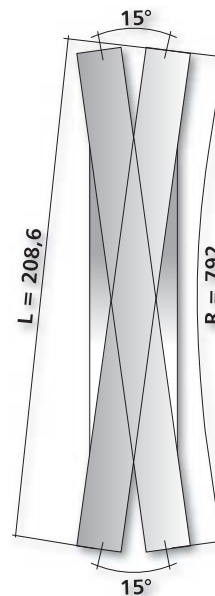

DKW II Bauart „Baeseler“; mit außen-
 liegenden, federnden Weichenzungen
 DKW II type „Baeseler“ with surrounding,
 spring-mounted switch points



Art.-Nr: 83391
 UVP in €: 55,90

Funktionsgleise / Function tracks

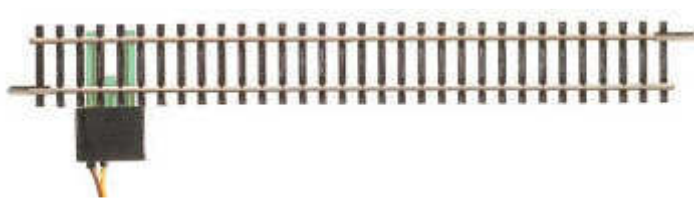

Gerades Anschlussgleis, 166 mm
(nicht für Digitalbetrieb geeignet)
Straight railway siding, 166 mm
(not for digital handling)

Art.-Nr: 83143
UVP in €:6,20

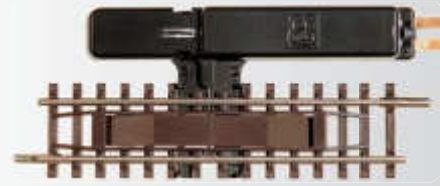

Entkupplungsgleis,
elektromagnetisch – 83,0 mm
Uncoupling track,
electromagnetic – 83,0 mm

Art.-Nr: 83201
UVP in €: 19,90

Gerades Anschlussgleis, 166 mm
(für Digitalbetrieb geeignet)
Straight railway siding, 166 mm
(for digital handling)

Art.-Nr: 83149
UVP in €: 6,20



Trenngleis – 41,5 mm
beidseitig getrennt
(ohne Anschlüsse)
Separating track
(without connections)

Art.-Nr: 83150 UVP in €: 2,45



Unterbrechergleis – 41,5 mm
einseitig getrennt
(ohne Anschlüsse)
Separating track (one side)
(without connections)

Art.-Nr: 83155 UVP in €: 2,45

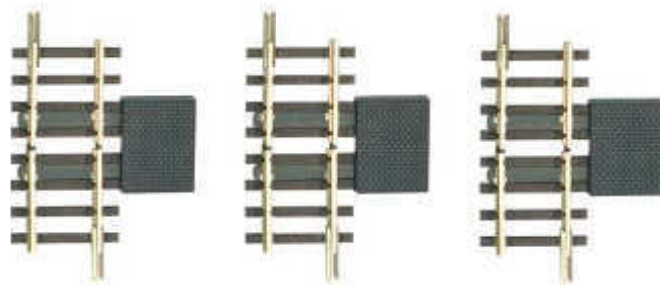

Kehrschleifengarnitur in Verbindung
mit Analogbetrieb
Terminal loop set in connection with
analogue operation

Art.-Nr: 83154
UVP in €: 16,00

Trenngleis – 41,5 mm
beidseitig getrennt,
mit vier getrennten
Anschlüssen/Separating
track with four separate
connections



Art.-Nr: 83151 UVP in €: 7,60

Schaltgleis – 41,5 mm
(geeignet für Pendelzug-
steuerung mit TFi2)
Switching track – 41,5 mm
(for automated shuttle train
control by TFi2)

Art.-Nr: 83158 UVP in €: 10,20



Unterbrechergleis –
41,5 mm einseitig getrennt,
mit zwei getrennten
Anschlüssen/Separating
track (one side) with two
separate connections



Art.-Nr: 83156 UVP in €: 6,20

Einpoliges Anschlusskabel mit Stecker für Funktions-
gleise (Länge 890 mm, Querschnitt Kabel 0,15 mm²)
Single-pole connection cable with a plug for functional
tracks (length 980 mm, cable diameter 0.15 mm²)

Art.-Nr: 08912 UVP in €: 2,45

Zweipoliges Anschlusskabel mit Stecker für Funktions-
gleise (Länge 890 mm, Querschnitt Kabel 0,15 mm²)
2-pole connection cable with a plug for functional tracks
(length 980 mm, cable diameter 0.15 mm²)

Art.-Nr: 08913 UVP in €: 5,00

Schaltgleis – 41,5 mm
zum Auslösen von
Schaltvorgängen durch
den fahrenden Zug
Switching track – to trigger
of switching actions by the
train driving

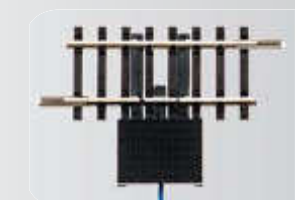

Art.-Nr: 83159 UVP in €: 6,20

Selbstbaumaterial, Bausätze/Do-it-yourself materials, kits

G 1
Gerades Schwellenband,
166 mm
Straight sleeper strip,
166 mm

Art.-Nr. 83001 UVP in €: 0,75

Bogen-Schwellenband
R 01 – R 267 mm/30°
Curved sleeper strip,
R 01 – R 267 mm/30°

Art.-Nr. 83016 UVP in €: 0,85

Bogen-Schwellenband
R 285 mm/15°
Curved sleeper strip,
R 285 mm/15°

Art.-Nr. 83003 UVP in €: 0,75

Bogen-Schwellenband
R 11 – R 310 mm/30°
Curved sleeper strip,
R 11 – R 310 mm/30°

Art.-Nr. 83008 UVP in €: 0,85

Bogen-Schwellenband
R 12 – R 310 mm/15°
Curved sleeper strip,
R 12 – R 310 mm/15°

Art.-Nr. 83009 UVP in €: 0,75

Bogen-Schwellenband
R 21 – R 353 mm/30°
Curved sleeper strip,
R 21 – R 353 mm/30°

Art.-Nr. 83006 UVP in €: 0,85

Bogen-Schwellenband
R 22 – R 353 mm/15°
Curved sleeper strip,
R 22 – R 353 mm/15°

Art.-Nr. 83007 UVP in €: 0,75

Bogen-Schwellenband
R 31 – R 396 mm/30°
Curved sleeper strip,
R 31 – R 396 mm/30°

Art.-Nr. 83011 UVP in €: 0,85

Bogen-Schwellenband
R 32 – R 396 mm/15°
Curved sleeper strip,
R 32 – R 396 mm/15°

Art.-Nr. 83012 UVP in €: 0,75

Flex-Schwellenband –
220 mm, mit dargestellten
Holzschwellen
Flexi sleeper strip, 220 mm

Art.-Nr. 83025 UVP in €: 0,75

Flex-Schwellenband –
125 mm, mit dargestellten
Betonenschwellen
Flexi sleeper strip, 125 mm

Art.-Nr. 83034 UVP in €: 0,85

Flex-Schwellenband –
80 mm, mit dargestellten
Stahlschwellen
Flexi sleeper strip, 80 mm

Art.-Nr. 83036 UVP in €: 0,75

Flexsteg-Bogenweiche –
Bausatz, 15°
passender Antrieb: 86112
Flexi-curved-points – kit
frog angle 15°, correspond-
ing point drive: – 86112

Art.-Nr. 83420 UVP in €: 11,80

Flexsteg-Bogenweiche –
Bausatz, 12°
passender Antrieb: 86112
Flexi-curved-points – kit
frog angle 12°, correspond-
ing point drive: – 86112

Art.-Nr. 83421 UVP in €: 13,00

IBW – Bausatz, links
passende Antriebe
– 83532, 83534
oder 86112

Inside-curved-points –
kit left, corresponding
point drive – 83532,
83534 or 86112

Art.-Nr. 83410 UVP in €: 11,40

IBW – Bausatz, rechts
passende Antriebe
– 83531, 83533 oder
86112

Inside-curved-points – kit,
right, corresponding point
drive – 83531, 83533 or
86112

Art.-Nr. 83411 UVP in €: 11,40

EW 1 – Bausatz, links
15°, passende Antriebe –
83532 oder 86112
left points – kit
frog angle 15°
corresponding point drive –
83532 or 86112

Art.-Nr. 83430 UVP in €: 10,50

EW 1 – Bausatz, rechts
15°, passende Antriebe –
83531 oder 86112
right points – kit
frog angle 15°
corresponding point drive –
83531 or 86112

Art.-Nr. 83431 UVP in €: 10,50

Schienenprofil – blank,
Neusilber 2,07 mm,
1000 mm
Rail profile – blank,
nickel silver, 2,07 mm,
1000 mm

Art.-Nr. 83500 UVP in €: 1,50

Prellbock (siehe S. 202),
Bausatz ohne Gleis
Buffer stop (p. 202),
kit, without track

Art.-Nr. 83440 UVP in €: 3,85

Isolierschienenverbinder,
braun (Beutel 20 St.)
Insulating rail joiners,
brown (bag of 20)



Art.-Nr. 85502 UVP in €: 3,85

Isolierschienenverbinder,
grau (Beutel 20 St.)
Insulating rail joiners,
grey (bag of 20)

Art.-Nr. 86101 UVP in €: 3,90

Schienenverbinder, blank
Neusilber (Beutel à 25 St.)
Rail joiners, nickel
silver, blank
(bag of 25)



Art.-Nr. 86102 UVP in €: 3,90

Schwellenklammern zur
Gleisbefestigung
(Beutel à 50 St.)
Sleeper stable
(bag of 50)



Art.-Nr. 83502 UVP in €: 2,75

Kontaktklammern brüniert
zur Stromzuführung
(Beutel à 20 Stück)
Contact clips (bag of 20)



Art.-Nr. 85506 UVP in €: 3,85

Modellgleis, brüniert/Advanced track, browned

Für optisch höhere Ansprüche sind folgende Artikel, in vorbildgerechter Farbgebung, im Angebot/ The following products are on offer in colours that are authentically in line with those of the prototype for higher optical demands:

Fertigartikel

**EW 1 (Fertigweiche/no kit)
rechts – 15°, brüniert
right points – 15°, browned**

Art.-Nr: 83326 UVP in €: 15,50

**EW 1 (Fertigweiche/no kit)
links – 15° – brüniert
left points – 15°, browned**

Art.-Nr: 83327 UVP in €: 15,50

**Flexgleis, brüniert, 664 mm
Flexi-track, browned,
664 mm**

Art.-Nr: 83495 UVP in €: 7,60

Abbildung zeigt eine montierte Bausatzweiche EW 2. / The picture shows the kit EW 2 mounted.

Selbstbaumaterial, Bausätze/Do-it-yourself materials, kits

**EW 1 (Bausatz/kit)
links – 15°, brüniert
left points – 15°, browned**

Art.-Nr: 83436 UVP in €: 11,80

**EW 1 (Bausatz/kit)
rechts – 15°, brüniert
right points – 15°, browned**

Art.-Nr: 83437 UVP in €: 11,80

**Flexsteg-Bogenweiche
(Bausatz/kit), 15°, brüniert
Flexi-curved-points, frog
angle 15°, kit, browned**

Art.-Nr: 83426 UVP in €: 13,80

**IBW (Bausatz/kit)
links, brüniert
Inside curved points, left,
browned**

Art.-Nr: 83416 UVP in €: 11,80

**IBW (Bausatz/kit)
rechts, brüniert
Inside curved points, right,
browned**

Art.-Nr: 83417 UVP in €: 11,80

**Flexsteg-Bogenweiche
(Bausatz/kit), 12°, brüniert
Flexi-curved-points, frog
angle 12°, kit, browned**

Art.-Nr: 83427 UVP in €: 15,50

**Schienenprofil,
2,07 mm,
Neusilber
brüniert,
1.000 mm**

Rail profile, 2.07 mm, nickel silver browned, 1.000 mm

Art.-Nr: 85500 UVP in €: 1,65

**Schienenverbinder, Neusilber
brüniert (Beutel 25 St.)
Rail joiners, nickel silver,
browned
(bag of 25)**

Art.-Nr: 85501 UVP in €: 5,65



Mögliche Einbauvarianten von flexiblen Weichenbausätzen am Beispiel des Weichenbausatzes 83420 als: Installation variants for flexible points kits, for example the points kit 83420, as:

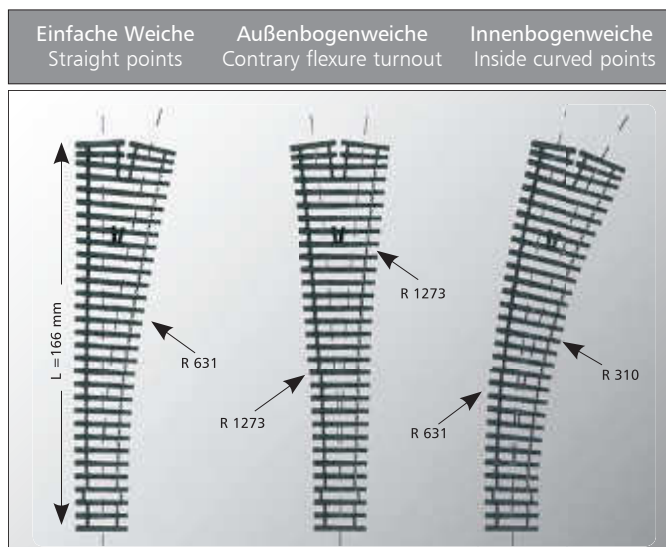

Tipps – Weichenbausätze/Tips – Points kits

Aus den Weichenbausätzen Art.-Nr. 83420, 83421 bzw. 83426 und 83427 lassen sich Einfach- und Bogenweichen bauen, mit denen man Weichenstraßen nach seinen eigenen Wünschen und Platzverhältnissen gestalten kann. The points kits with article no. 83420, 83421, 83426 and 83427 can be used to produce both straight and curved points, for points configurations tailored to individual wishes and the available space.

Montagetipps/Installation tips

- Den Schwellenrost zuerst nach dem Gleisverlauf auf der Anlagengrundplatte fixieren. / First fix the sleeper strip to the layout base in accordance with the desired track curves.
- Jetzt mit einem Fön den Schwellenrost erwärmen. / Now warm the sleeper strip with a hair dryer.
- Die flexiblen Schwellenstege passen sich nach dem Auskühlen der gewünschten Geometrie an. / After cooling, the flexible sleepers follow the desired geometry.

Tipps und Tricks / Tips and tricks

- Zum Ablängen von Schienenprofil sollten Sie unbedingt einen Gleisschneider oder eine Trennscheibe benutzen.
- Anschließend sollte die Trennkante mit einer feinen Feile entgratet werden.
- Um das Einziehen des Profils in den Schwellenrost zu erleichtern, empfiehlt es sich, den Profilfuß anzuschrägen.

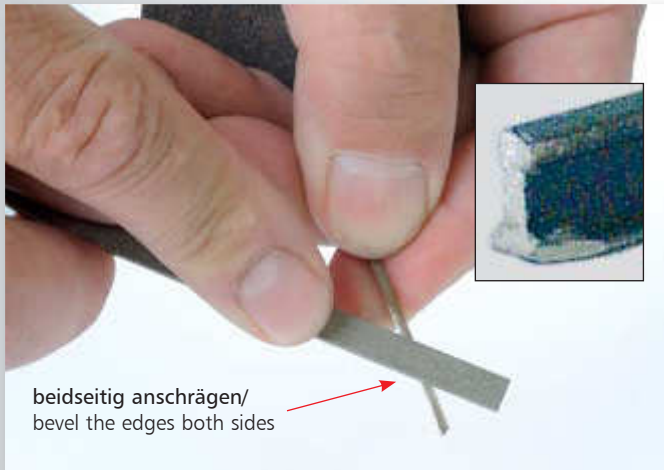

- Das Profil niemals mit einem Seitenschneider, sondern mit einer Flach- oder Spitzzange in den Schwellenrost einziehen!
- In Gleisbögen unbedingt gegenüberliegende Schienenstöße vermeiden, der Gleisbogen verläuft an diesen Stellen nicht gleichmäßig, es kommt zu un schönen Knicken (siehe auch Hinweis Seite 206).
- Beim Verlegen im Gleisbogen das Profil vor dem Einschoben entsprechend des Gleisradius vorbeugen.
- Flexgleise bei Radien über R 396 und als Ausgleichstücke verwenden.
- Bei brünierten Gleisen: Durch die vorbildgerechte farbliche Behandlung des Profils muss vor dem Anlöten von Kabeln zur Stromspeisung die entsprechende Stelle am Profil geblankt werden. Dazu verwendet man einen Glasfaserstift.

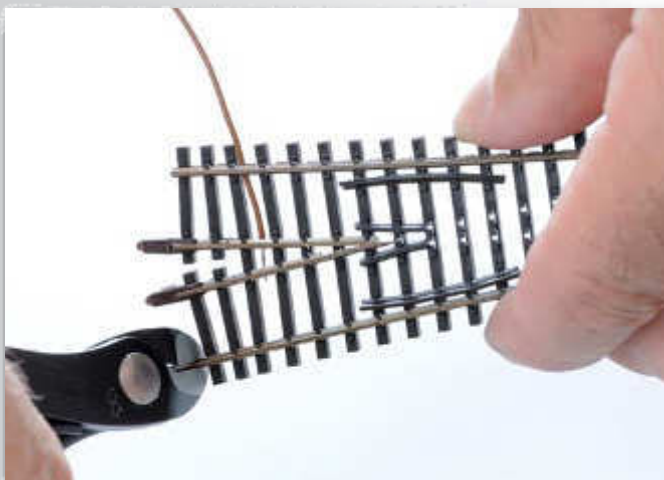

- Always use a proper track cutter or abrasive cut-off wheel when cutting rail profiles to length.
- Subsequently, deburr the cut edges carefully using a fine file.
- It is easier to insert the profile into the sleeper strip, if the profile foot is bevelled first.
- Do not use side cutters to insert the profile into the sleeper strip, but use instead flat or pointed pliers!
- When laying track curves, make sure that the individual rail joints are staggered and not opposite each other, otherwise the curve will not run evenly at these track joints and disturbing kinks in the track will be the result (see also note on page 206).
- Again when laying track curves, the profile should be pre-bent to the required track radius before insertion.
- Use flexi-track for radii in excess of R 396 and to compensate length differences.
- As the profiles have been pre-weathered to ensure realistic colouring, the designated solder points for power supply cables must be bared accordingly. This is best done with a glass fibre pen.

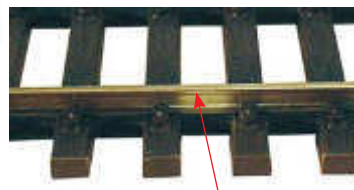

Profil mit einem Glasfaserstift reinigen/
clean the profile with a glass-fibre pen

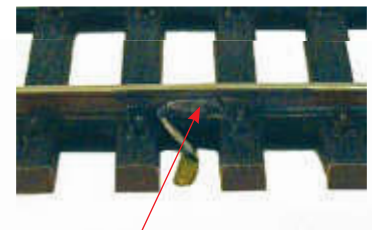

Lötstelle mit entsprechender Farbe behandeln/
touch up the solder point with the corresponding colour



TILLIG-Weichenantriebe für Oberflur-Betrieb / Operating gear for surface-mounted operation



Art.-Nr: 83531
UVP in €: 16,90

Elektrischer Weichenantrieb für Rechtsweichen
Electric operating gear for right points



Art.-Nr: 83532
UVP in €: 16,90

Elektrischer Weichenantrieb für Linksweichen
Electric operating gear for left points



Art.-Nr: 83533
UVP in €: 11,40

Hand-Weichenantrieb für Rechtsweichen
Manual operating gear for right points



Art.-Nr: 83534
UVP in €: 11,40

Hand-Weichenantrieb für Linksweichen
Manual operating gear for left points

Hinweis/Note: Art. 83531/83532 sind mit Endabschaltung / item-no. 83531/83532 with limit switching



Weichenantrieb für alle Weichen des Standard-Gleissystems Art. 06110 ff.
Electric operating gear for points of the TT-hollow profile track, item no. 06110 ff.

Art.-Nr: 08330
UVP in €: 12,30

Unterflur-Motor-Weichenantrieb / Undermounted points operating motor

Unser neuer Unterflurantrieb besteht nun aus einem Grundkörper, der nicht fest in ein Gehäuse eingebaut ist. Daraus resultiert eine wesentliche Vereinfachung bei der Montage unter der Anlage sowie bei der Einstellung des Stellweges. Nach erfolgter Installation des Antriebs wird einfach die beiliegende Staubabdeckung auf den Antrieb gesteckt. Die technischen Parameter des Antriebes bleiben unverändert.

Our new underfloor mounted drive consists of a base body that is not permanently affixed in a housing. This results in a marked simplification during installation beneath the system and also when setting the travel range. The accompanying dust cover will simply be placed on the drive once it has been installed. The technical parameters of the operating motor remain unchanged.

Über den potentialfreien Umschalter kann die Herzstückstromversorgung erfolgen, Gleisabschnitte mit Fahrstrom versorgt werden und Zubehörartikel geschaltet werden.

The isolated switcher can be used to supply current to the frog, to provide traction current to track sections and to switch accessories.

Einbauskizze /
Mounting position:

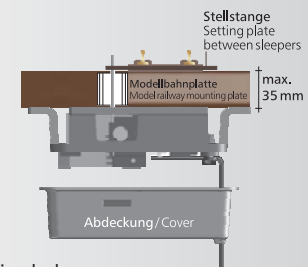

Art.-Nr: 86112
UVP in €: 21,30



Technische Daten/Technical data:

Betriebsspannung / Operating voltage: 14 – 16V Wechselspannung
Stromaufnahme / Current consumption: 75 mA
Stellweg einstellbar / Switch travel, adjustable: 2 – 10 mm
Stellkraft / Switching force: 1,47 N = 150 g
Schaltstrom des potentialfreien Umschalters /
Switched current of the isolated switcher: 500 mA (max. 24V)
Abmessungen / Dimensions: 62 x 49 x 23 mm

Gleisschablone / Track strickle

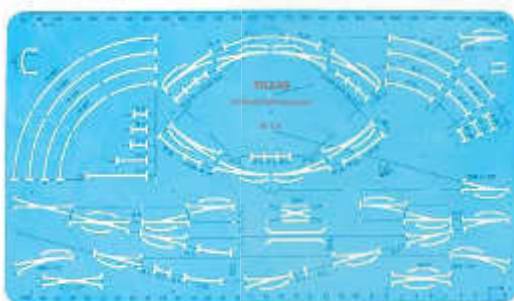

Gleisschablone zum Zeichnen von Gleisplanentwürfen im Maßstab 1:5, für Feinminenstifte 0,5 mm und Tusche geeignet.

Track planning template appropriate for the drawing of the track plan drafts to a scale of 1:5, for fine lead mechanical pencils 0.5 mm and ink.

Art.-Nr: 83517
UVP in €: 22,90



STYROSTONE®-Gleisbettung

STYROSTONE®-Gleisbettung

Mit der STYROSTONE®-Gleisbettung ist es möglich, schnell und vorbildgetreu die Gleise des TT-Modellgleissystems einzuschottern.

Die Vorteile unseres Systems sind:

- Vorbildentsprechendes Material: Steinschotter
- Schnelle Verarbeitung durch Eindrücken der Gleise
- Keine Nägel, kein Klebstoff oder Leim am Gleis
- Gleise können wieder herausgenommen werden
- Keine Wanderung der Weichmacherbestandteile von Schwellenband und Gleisbettungsgrundkörper dadurch auch äußerst langlebig
- Sehr gute Geräuschdämmung
- Leichte Bearbeitbarkeit der Bettungskörper mit Bastelmesser

Die Bettung wird bei Bogengleisstücken und Geraden ohne Böschung gefertigt, so dass mehrere parallele Gleise aneinander gelegt werden können. Zur Auswahl stehen dunkel oder hell eingefärbte Gleisbettungen zur Verfügung.

Die Böschung ist im Grundkörper vorbereitet und kann mit einem Bastelmesser herausgelöst werden, um eingleisige Strecken darzustellen. Mit dem Steinschotter können Bereiche zwischen den Gleisen und neben dem Schotterbett bestreut werden. Separate Böschungstreifen gestatten die Reparatur verschnittener Teile. Ein zusätzlich unter die Gleisbögen geklebter Streifen ermöglicht die realistische Überhöhung der Gleise in den Bogen. Die Verlegung der Schotterbettung ist sehr einfach. Die Gleise werden in die Bettung gedrückt und STYROPAL-Kontaktklebstoff dünn auf die Unterseite der Gleisbettung aufgetragen. Nach ca. 15 – 20 min. Antrocknungszeit wird die Gleisbettung fest angedrückt. (Der Anpressdruck entscheidet über die Haftfestigkeit!) Arbeitsmittel sind sofort nach Gebrauch mit Wasser zu reinigen.

STYROSTONE®-track bedding

STYROSTONE®-track bedding permits fast and true-to-life modelling of a ballast bed for the TT Advanced track system.

The advantages of our system are:

- True-to-original material: stone ballast
- Fast laying by pressing in the tracks
- No nails or adhesives required to fix the track
- Tracks can be removed again later
- No migration of plasticisers from the sleeper strip and track bedding core, and consequently excellent durability
- Very good noise-damping effect
- Simple cutting of the bedding core with a craft knife

The bedding is manufactured without embankments for both curved and straight track sections, to enable several tracks to be laid parallel to each other. The track bedding is supplied with a choice of either dark and light colouring.

The necessary cutting marks for an embankment, however, have already been incorporated into the bedding core, meaning that the embankment strips only need to be trimmed off with a craft knife to produce single-track lines. The areas between the tracks and alongside the ballast bed can be strewn with stone ballast. Separate embankment strips permit repairs to bedding sections which may have been prepared incorrectly. Additional strips inserted under the actual bedding provide for a realistic banking of the track in curves. The ballast bed is very simple to lay. The tracks are pressed into the track bedding, and STYROPAL contact adhesive is spread thinly on the underside of the bedding. After a drying time of approx. 15 – 20 min., the track bedding is pressed firmly into place. (It is this application pressure which is decisive for the strength of adhesion!) All tools and aids should be cleaned with water immediately after use.

Gleisbettung für:
Track bedding for:

Gleisbettung – dunkel (braun)/
Track bedding – dark (brown)

Gleisbettung – hell (grau)/
Track bedding – light (grey)

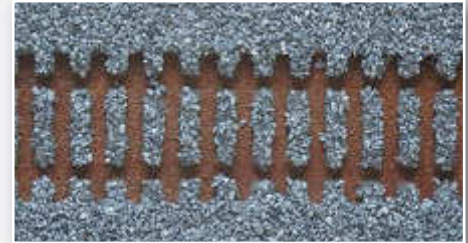
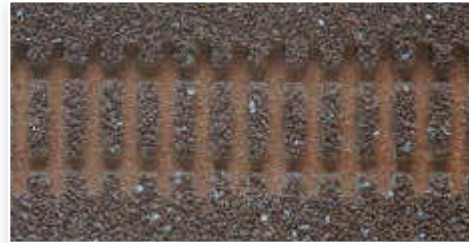

Gerades Gleis/
Straight track

332 mm:
G 1, G 2, G 4, G 5

332 mm:
G 1, G 2, G 4, G 5

Art.-Nr: 86301 UVP in €: 2,35

Art.-Nr: 86351 UVP in €: 2,35



43 mm:
G 3

43 mm:
G 3

Art.-Nr: 86306 UVP in €: 2,35

Art.-Nr: 86356 UVP in €: 2,35

Gebogenes Gleis/
Curved track

R 01 – R 04, 30°

R 01 – R 04, 30°

Art.-Nr: 86302 UVP in €: 2,35

Art.-Nr: 86352 UVP in €: 2,35

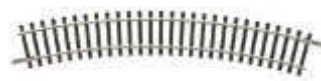

R 11 – R 14, 30°

R 11 – R 14, 30°

Art.-Nr: 86303 UVP in €: 2,35

Art.-Nr: 86353 UVP in €: 2,35

R 21 – R 24, 30°

R 21 – R 24, 30°

Art.-Nr: 86304 UVP in €: 2,35

Art.-Nr: 86354 UVP in €: 2,35

R 31 – R 32, 30°

R 31 – R 32, 30°

Art.-Nr: 86305 UVP in €: 2,35

Art.-Nr: 86355 UVP in €: 2,35

Flexgleis/Flexi-track

700 mm
(Holzschwellen / wooden sleepers)

950 mm
(Holzschwellen / wooden sleepers)



Art.-Nr: 86308 UVP in €: 5,70

Art.-Nr: 86358 UVP in €: 5,70

700 mm
(Betonschwellen / concrete sleepers)

700 mm
(Betonschwellen / concrete sleepers)



Art.-Nr: 86310 UVP in €: 5,70

Art.-Nr: 86360 UVP in €: 5,70

Gleisbettung für:
Track bedding for:

Gleisbettung – dunkel (braun)/
Track bedding – dark (brown)

Gleisbettung – hell (grau)/
Track bedding – light (grey)

Einfache Weiche/
Straight points

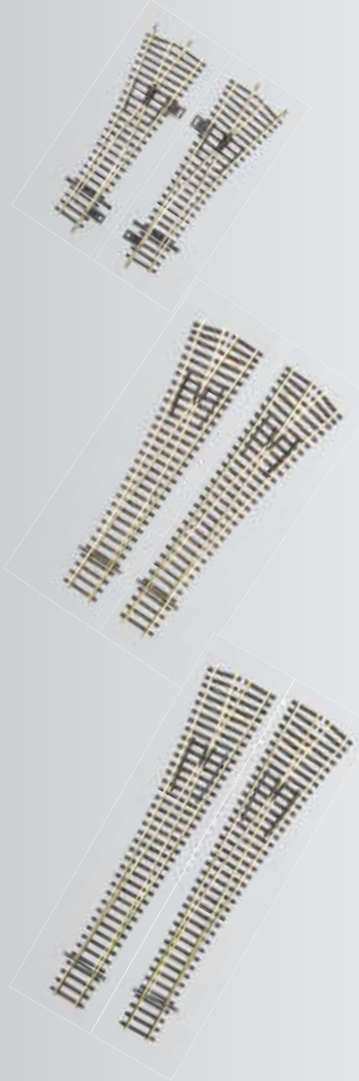

EW 1 (83321) 15°
rechts/right branch

Art.-Nr: 86311 UVP in €: 4,80

EW 1 (83322) 15°
links/left branch

Art.-Nr: 86312 UVP in €: 4,80

EW 1 (83321) 15°
rechts/right branch

Art.-Nr: 86361 UVP in €: 4,80

EW 1 (83322) 15°
links/left branch

Art.-Nr: 86362 UVP in €: 4,80

EW 2 (83331) 15°
rechts/right branch

Art.-Nr: 86331 UVP in €: 5,50

EW 2 (83332) 15°
links/left branch

Art.-Nr: 86332 UVP in €: 5,50

EW 2 (83331) 15°
rechts/right branch

Art.-Nr: 86381 UVP in €: 5,50

EW 2 (83332) 15°
links/left branch

Art.-Nr: 86382 UVP in €: 5,50

EW 3 (83341) 12°
rechts/right branch

Art.-Nr: 86341 UVP in €: 5,70

EW 3 (83342) 12°
links/left branch

Art.-Nr: 86342 UVP in €: 5,70

EW 3 (83341) 12°
rechts/right branch

Art.-Nr: 86391 UVP in €: 5,70

EW 3 (83342) 12°
links/left branch

Art.-Nr: 86392 UVP in €: 5,70

Innenbogenweiche/
Curved points

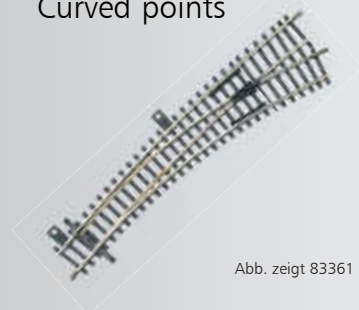

IBW (83361) 15°
rechts/right branch

Art.-Nr: 86315 UVP in €: 4,80

IBW (83362) 15°
links/left branch

Art.-Nr: 86316 UVP in €: 4,80

IBW (83361) 15°
rechts/right branch

Art.-Nr: 86365 UVP in €: 4,80

IBW (83362) 15°
links/left branch

Art.-Nr: 86366 UVP in €: 4,80

Abb. zeigt 83361

Gleisbettung für:
Track bedding for:

Gleisbettung – dunkel (braun)/
Track bedding – dark (brown)

Gleisbettung – hell (grau)/
Track bedding – light (grey)

Kreuzung/
Crossing



Abb. zeigt 83170

K 1 (83161) 15°

Art.-Nr: 86324 UVP in €: 4,80

K 1 alt (83160) 15°

Art.-Nr: 86321 UVP in €: 4,80

K 2 (83170) 30°

Art.-Nr: 86322 UVP in €: 4,80

K 1 (83161) 15°

Art.-Nr: 86374 UVP in €: 4,80

K 1 alt (83160) 15°

Art.-Nr: 86371 UVP in €: 4,80

K 2 (83170) 30°

Art.-Nr: 86372 UVP in €: 4,80

Doppelte
Kreuzungsweiche/
Double-slip points



Abb. zeigt 83391

DKW I (83300) 15°

Art.-Nr: 86319 UVP in €: 5,50

DKW II (83391) – Baeseler

Art.-Nr: 86320 UVP in €: 8,10

DKW I (83300) 15°

Art.-Nr: 86369 UVP in €: 5,50

DKW II (83391) – Baeseler

Art.-Nr: 86370 UVP in €: 8,10

Entkupplungsgleis/
Uncoupling track



83 mm (83201)

Art.-Nr: 86326 UVP in €: 4,80

83 mm (83201)

Art.-Nr: 86376 UVP in €: 4,80

Grundplatte
(ohne Schotter)/
Base plate
(without bedding)

280 x 80 mm

Art.-Nr: 86421 UVP in €: 2,25

280 x 80 mm

Art.-Nr: 86422 UVP in €: 2,25

Böschungstreifen/
Embankment strip

L = 700 mm

Art.-Nr: 86411 UVP in €: 4,50

L = 700 mm

Art.-Nr: 86412 UVP in €: 4,50



STYROPAL-Kontaktkleber
STYROPAL-contact adhesive

Art.-Nr: 86401
UVP in €: 4,90

Wasserverdünnbar, nach dem Aushärten wasserbeständig, zum Befestigen von STYROSTONE®-Gleisbettung und zum Fixieren von STYROSTONE®-Schotter.

Dilutable with water, waterproofed after curing used to fix STYROSTONE®-Track-Bedding and STYROSTONE®-Ballast.



Schotter dunkel, 500 g
Ballast dark, 500 g

Art.-Nr: 86406
UVP in €: 12,50



Schotter hell, 500 g
Ballast light, 500 g

Art.-Nr: 86407
UVP in €: 12,50

Hinweis / Note: Praktische Tipps zur Verlegung: Seite 206 – 207. / Practical tips on the laying of track bedding: Page 206 – 207.

Praxistipps zur Verlegung

Zur vorbildgerechten Gestaltung einer Modellbahnanlage gehört das Einschottern der Gleise. Dafür eignet sich die TILLIG STYROSTONE®-Gleisbettung besonders gut. Lieferbar ist die Gleisbettung in zwei Farbtönen. Braun eingefärbt, findet sie Verwendung bei älteren Streckenabschnitten und hellgrau für neu gebaute Gleisstraßen. Unsere Gleisbettung wird unter Verwendung hochwertiger Natur- und Kunststoffe in sorgfältiger Handarbeit hergestellt. Der Gleisbettkörper besteht aus extrudiertem Polystyrol-Hartschaum. Das Material ist absolut verrottungsfest, UV-beständig und schwer entflammbar. Der Schotterbelag besteht aus elastischer Gummikorkfolie, auf welcher der form- und maßstabsgerechte Steinschotter aufgeklebt ist. Da die Schwellen der Gleise unten etwas breiter sind als oben, sollten Sie den Steinschotterbelag vor dem Eindrücken der Gleise mit dem Fön oder einer Heißluftpistole auf ca. 50° C erwärmen. Das gilt auch beim Herausnehmen der Gleise aus der Bettung. Nach dem Abkühlen des Steinschotterbelages sitzt das Gleis so fest in der Bettung, dass eine zusätzliche Befestigung mit Nägeln nicht erforderlich ist.

Zum Befestigen auf der Anlagengrundplatte empfehlen wir STYROPAL-Kontaktklebstoff (Art.-Nr.: 86401).

Die Gleisbettung ist so vorbereitet, dass bei eingleisigen Strecken auf beiden Seiten, oder bei zweigleisigen Strecken auf einer Seite, die Böschung des Schotters gebildet werden kann. Dazu muss der vorgeschchnittene Styroporkeil entfernt und der Steinbelag seitlich an den Gleisbettkörper angeklebt werden.

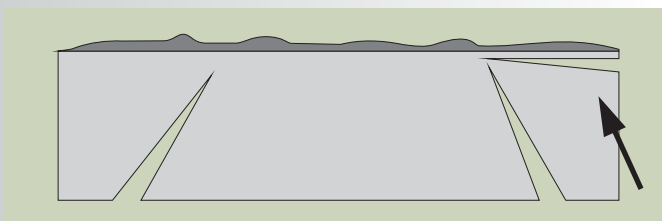
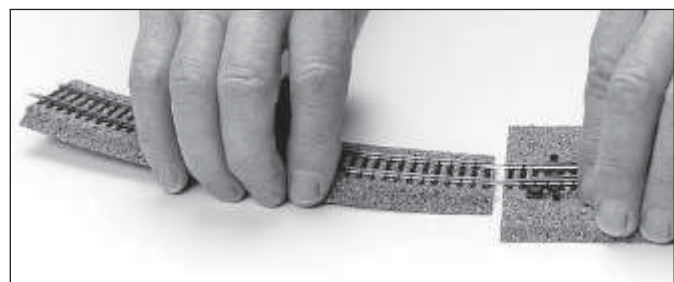
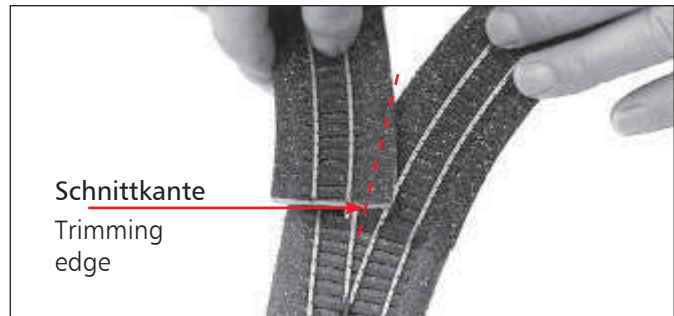

Styroporkeil entfernen/trimm the polystyrene wedge

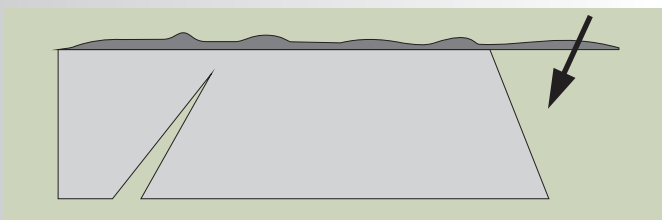

Steinbelag ankleben/glue to the stone surface



An den Weichenabgängen muss die Gleisbettung angepasst werden. Dazu steckt man ein Teil an die bereits verlegte Weiche und das andere legt man an den Abzweig darüber. Nun können die überlappenden Stücke mit dem Bastelmesser abgeschnitten werden. Die Stoßstellen können anschließend mit dem jeweiligen farblichen Schotter überdeckt werden.

Prinzipiell sollte vor dem Verlegen der Gleisbettung der Verlauf auf der Anlagengrundplatte aufgezeichnet sein. Die Gleiselemente sind vor dem Verkleben der Gleisbettung in diese einzudrücken.

Anlagengrundplatte und Gleisbettung sind gleichmäßig mit STYROPAL-Kontaktklebstoff einzustreichen. Hier kann eine größere Stückzahl vorgearbeitet werden, da der Kleber erst nach dem Trocknen haftet. Sind die Klebeflächen trocken, kann das Gleis angesteckt und die Gleisbettung Stück für Stück angegedrückt werden.

Die Gleisbettung für Flexgleis muss vor dem Andrücken in die gewünschte Richtung gebracht werden. Um ein vorzeitiges Kleben der gesamten Gleisbettung zu verhindern, legt man ein Blatt Papier zwischen die bereits mit Klebstoff versehene Bettung und die Anlagengrundplatte. Dieses entfernt man dann Stück für Stück und drückt die Gleisbettung an.

Practical tips on the laying of track bedding

Reproduction of the original ballast is an important aspect when designing a true-to-life layout. TILLIG STYROSTONE® track bedding is especially convenient in this respect. The track bedding can be supplied in two different colours: brown for use along older track sections, and light-grey for newly built lines. Both variants are the result of careful manual production using only high-quality natural and synthetic materials. The core of the track bedding is composed of extruded hard-foamed polystyrene. This material is absolutely rot-proof, UV-resistant and flame-resistant. The ballast layer comprises an elastic rubber cork foil, to which the true-to-scale stone ballast is adhered. As the sleepers of the tracks are wider at the bottom than at the top, you should use a hair dryer or the like to warm the stone ballast to approx. 50°C before pressing in the track. The same applies when removing the track from the bedding. When the stone ballast layer cools, the track is seated so firmly in the bedding that additional fixing with nails is no longer necessary. For fixing on the layout base, we recommend the use of STYROPAL contact adhesive (item no.: 86401). The track bedding is specially prepared to permit embankments to be recreated – either on both sides for a single-track line, or on one side for lines with two tracks.

To this end, the pre-cut polystyrene wedge is trimmed and the stone surface is glued to the side of the track bed.

At points branches, the track bedding needs to be cut to shape. To do so, one strip is laid along the already mounted points, and a second over the top for the branch. The overlap can then be trimmed off using a sharp craft knife. The join between the two sections can be covered with ballast of the appropriate colour. Before laying track bedding, you should always mark out the course of the tracks on the layout base. The track elements should be pressed into the track bedding before the latter is glued down. Apply an even coating of STYROPAL contact adhesive to the layout base and the track bedding. Several sections can be prepared at once, as the adhesive does not bond until it has dried. Once the coated surfaces have dried, the track can be joined together and pressed down section by section.

The track bedding for flexi-track must be bent to the desired curves before finally being pressed into place. To prevent premature sticking of the whole track bedding, it is recommended to lay sheets of paper between the adhesive-coated bedding and the layout base. This paper can then be removed piece by piece to allow the track bedding to be pressed down and fixed.

Überhöhungstreifen für Gleisbögen, ca. 700 mm lang/
Banking strips for track curves, length approx. 700 mm

Art.-Nr: 86413

UVP in €: 1,60

Um das Verlegen im Bogen zu ermöglichen, sind mit der Schere, je nach Radius, in bestimmten Abständen kleinere Keile herauszuschneiden. Anschließend wird der Überhöhungstreifen entsprechend dem vorgezeichneten Streckenverlauf auf der Unterlage festgeklebt und das STYROSTONE®-Gleisbett wird nun auf den Überhöhungstreifen aufgeklebt.

To facilitate laying in the bend smaller wedges must be cut out, depending on the radius, at certain intervals with scissors. Following this the banking strips are stuck to the base in accordance with the sketched out route of the line and STYROSTONE® track bed is now stuck to the banked strips.



TILLIG-Fahrregler TFi2 mit Impulsbreitenregelung TILLIG-Controller TFi2 with pulse width control

- Für alle Gleichstrommodelle 12V =
- Geeignet auch für Glockenankermotoren
- Nahezu konstante Betriebsspannung als gepulste Rechteckspannung
- Ausgangsstrom max. 1 A
- Automatische Abschaltung bei Kurzschluss und Überlast
- Stromversorgung durch energieeffizientes Schaltnetzteil (im Lieferumfang enthalten)
- Aneinanderreihbares Pultgehäuse, Maße ca. 138 x 80 x 40 mm
- For all 12V DC-models
- Compatible with bell-armature motors
- Practically constant operating voltage as a clean, noise-free square wave
- Output current approx. 1 A
- Automatic cut-out in case of short-circuit or overload
- Power supply via mains power adapter (supplied)
- Housing suitable for side-by-side mounting, Demensions approx. 138 x 80 x 40 mm

NEW GENERATION

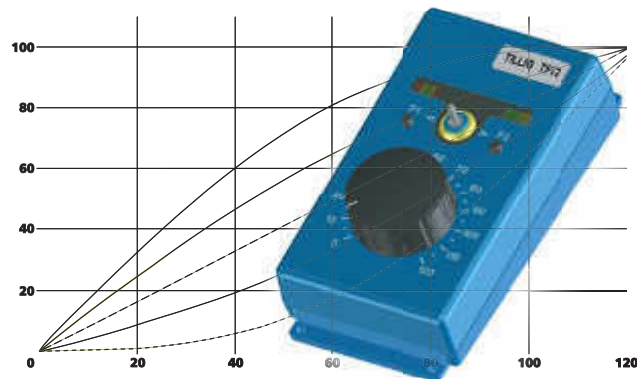

Mit automatischer Pendelzugsteuerung
With automatic shuttle train control

Art.-Nr: 08131
UVP in €: 140,90

Eigenschaften und Funktionen wie im digitalen Fahrbetrieb/Same properties and functions as digital systems:

- Hervorragende Fahreigenschaften im gesamten Geschwindigkeitsbereich
- Extreme Langsamfahrten möglich
- Linearer Geschwindigkeitsanstieg im gesamten Regelbereich oder alternativ 4 verschiedene nicht-lineare Regelkurven wählbar
- Abbremsen zum Stillstand und wieder Anfahren mit Brems-/Anfahrverzögerung durch Tastendruck
- Excellent running characteristics over the whole speed range
- Extremely slow running speeds possible
- Linear speed increase over the whole control range, alternatively, 4 different non-linear control curves can be selected
- Automatic deceleration to stand still and restarting with braking/starting delay

Impulsbreitenregelung in neuer Dimension

- Nahezu konstante LED-Beleuchtung der Modelle, auch im Langsamlauf
- Fahrtrichtungsgerechte LED-Triebfahrzeugbeleuchtung trotz Impulsspannung

Pulse width control of a new dimension:

- Practically constant LED illumination in the models, even when travelling slowly
- Correct motor-coach lighting for the chosen running direction, despite the pulsed voltage

Komfortable Bedienung

- Geschwindigkeitsregelung durch Drehknopf mit großem Stellweg (270°)
- Leistungsanzeige als ringförmiges LED-Band korrespondierend zur Reglerstellung
- Umschaltung der Fahrtrichtung durch Kippschalter
- Fahrtrichtungsanzeige durch unterschiedliche Farben in der Leistungsanzeige

Convenient operation:

- Wide range of adjustment for speed control at the rotary knob (270°)
- Output display as an LED ring strip corresponding to the controller position
- Toggle switch for running direction changes
- Running direction indicated by colour-coding of the display

Mit automatischer Pendelzugsteuerung

- Pendelzugautomatik ohne zusätzliche Relais-schaltung (mit Gleiskontakten mit Diodenbeschaltung – Platine Art. 08401/Schaltgleise 83158/83758)
- Beliebig viele Zwischenhalte im Pendelzugmodus
- Automatische Aktivierung der voreingestellten Brems- bzw. Beschleunigungszeit sowie Haltezeit
- Automatik abschaltbar

With automated shuttle train control

- Shuttle train automatic control without an additional relay circuit (with rail contacts with diode circuit – Printed circuit board product no. 08401/Switching tracks 83158/83758)
- Any number of stops in the shuttle train mode
- Automatic activation of the preset braking and acceleration time as well as the stopping time
- The automatic control can be switched off



Platine Art. 08401



TILLIG Fahrregler/TILLIG-Controller:

Analog-Fahrregler mit Zubehöranschluss
Analogue drive control with accessory output

Art.-Nr: 08132

UVP in €: 84,90



- Für alle Gleichstrommodelle 12V =
- Nahezu konstante Betriebsspannung als gepulste Rechteckspannung
- Fahrstrom 0,5A
- Geschwindigkeits- und Richtungssteuerung durch Drehknopf mit Nullstellung
- Integrierter Zubehöranschluss (max. 1,4A)
- Kontroll-Leuchten: Bereitschaftsanzeige Fahrstrom und Zubehör, Kurzschlussanzeige
- Automatische Abschaltung bei Kurzschluss und Überlast
- Stromversorgung durch stromeffizientes Schaltnetzteil (im Lieferumfang enthalten)
- Wahlweise als Handgerät oder Tischgerät nutzbar
- Inkl. praktischer Halterung für Anlagengrundplatte, mit der das Gerät leicht und bequem aufgesteckt und wieder gelöst werden kann

- For all 12V DC-models
- Practically constant operating voltage as a clean, noise-free square wave
- Track current 0,5A
- Speed and direction control at the rotary knob with neutral position
- Integrated accessory output (approx. 1,4A)
- Control lamps for track current, accessories and cut-out display
- Automatic cut-out in case of short-circuit or overload
- Power supply via mains power adapter (supplied)
- Useable as hand-held unit or tabletop unit
- Attachment for mounting plate included

Universal-Zubehör-Transformator
Ausgangsspannung 14V~ und 16,5V~,
max. Belastung 45VA gesamt
Universal accessory transformer
output voltages 14V~ and 16,5V~,
total output rating 45VA



Art.-Nr: 08122 UVP in €: 78,90

Schaltgleis Nachrüstsatz – Leiterplatte mit 2 Dioden zum
direkten Anschluss an TFi2, zum Nachrüsten von Gleisen
für alle Spurweiten

Terminal board with 2 diodes for direct connection to TFi2
controller, for the conversion of tracks for all track widths

Art.-Nr: 08401 UVP in €: 5,10

Tastentpult für Moment- oder
Dauerstrom, aneinander reihbar
Control desk for short impulses or persistent current



Art.-Nr: 08211 UVP in €: 10,20

Schaltrelais,
zweipolig
Switching relais,
double-pole



Art.-Nr: 08410 UVP in €: 16,50

Leistungsaufnahme von TILLIG-Zubehörartikeln/Power consumption of TILLIG accessory products

(Bei Betrieb mit 16 V Wechselspannung, Angaben sind Näherungswerte/
the data contains approximate values in the case of operation with 16V AC voltage)

Schaltrelais Art. 08410/switching relay:	ca. 1000 mA (*)
Schaltrelais Art. 08414/switching relay:	ca. 15 mA (*)
Schaltrelais Art. 08415/switching relay:	ca. 75 mA (*)
Entkupplungsgleis Art. 83201/Uncoupling track:	ca. 1100 mA (*)
Entkupplungsgleis Art. 83801/Uncoupling track:	ca. 150 mA (*)
Oberflur-Weichenantrieb Art. 83531/83532/Electric operating gear:	ca. 1100 mA (*)
Bettungsgleis-Weichenantrieb Art. 83960/Electric operating gear (bedding track):	ca. 1100 mA (*)
Unterflur-Weichenantrieb Art. 86112/Undermounted points operating motor:	ca. 75 mA

(*) = kurzzeitiger Impulsstrom/temporary impulse current

Leistungsaufnahme von TILLIG-Rollmaterial/Power consumption of TILLIG rolling stock

(Bei Betrieb mit 12 V Gleisspannung, Angaben sind Näherungswerte/
the data contains approximate values in the case of operation with 12V track voltage)

Triebfahrzeug mit Glühlampenbeleuchtung/Tractive unit with light bulb illumination	ca. 200 ... 300 mA
Triebfahrzeug mit LED-Beleuchtung/Tractive unit with LED lighting	ca. 150 ... 250 mA
Steuerwagen mit LED-Schlussbeleuchtung/Driving cab coach with LED rear lighting	ca. 5 ... 20 mA
Reisezugwagen mit eingebautem LED-Innenbeleuchtungsbausatz (S. 229)	ca. 5 ... 250 mA
Railway carriage with installed LED-Interior lighting module (refer also to page 229)	
Eilzugwagen mit Glühlampenbeleuchtung/Express train coaches with light bulb illumination	ca. 100 ... 120 mA

Hinweis/Note:

Bitte beachten Sie, dass es sich insbesondere bei der Stromaufnahme von Triebfahrzeugen nur um ungefähre Durchschnittswerte handelt. Der genaue Wert kann je nach Alter des Fahrzeuges, der Konstruktion des Modells sowie dem Grad des Verschleißes von Motor und Getriebe des Modells entsprechend abweichen.

Please note that in terms of the power consumption of tractive units these are only approximate average values. The precise value can differ accordingly depending on the age of the vehicle, the construction of the models as well as the degree of wear and tear of the motor and the gearing of the model.

Unser TILLIG-Kupplungssystem / TILLIG coupling system

- Zuverlässig im Fahrbetrieb
- Sanftes Ein- und Entkuppeln (mit Entkupplungsgleis/Handentkupppler)
- Ideale Kupplungsform
- Kurzkupplungseffekt bei Fahrzeugen mit Kurzkupplungs kinematik
- Reliable driving operation
- Gentle coupling and uncoupling (with uncoupling ramp/Manual uncoupler)
- Ideal coupling form
- Short coupling effect for vehicles with short coupling kinematics

Unser innovatives TILLIG-Kupplungssystem besticht durch völlig neue technische und optische Eigenschaften und löste unser früheres System der Bügelkupplung ab. Die früher eingesetzte Bügelkupplung führen wir weiterhin als START-Kupplung in unserem Sortiment.

Our innovative TILLIG coupling system captivates users through its completely novel technical and optical properties and replaces our earlier bow coupling system. We continue to offer the bow coupling used up to now in our range as a STARTER coupling.



Überblick Kupplungsausführungen/Overview of coupling type



für NEM-Aufnahme
Beutel à 8 Stück (Bausatz)
for NEM-coupling pocket
bag of 8 (kit)

Art.-Nr: 08840 UVP in €: 9,70

Beutel à 56 Stück (Bausatz)
bag of 56 (kit)

Art.-Nr: 08841 UVP in €: 51,90



für Aufnahme der 4-achsigen
V 180, Beutel à 2 Stück
for coupling pocket of V 180
(4-axle version), bag of 2

Art.-Nr: 08842 UVP in €: 3,85



für Aufnahme der 6-achsigen V 180,
NoHAB, T334 mit neuem Rahmen/
neuer Bodenplatte
Beutel à 2 Stück
for coupling pocket of V 180 (6-axle
version), NoHAB, T334 with new frame
and new base plate bag of 2

Art.-Nr: 08843 UVP in €: 3,85



für Kuppelkastenaufnahme
(E 44, BR 243, BR 119, BR 01
(alte Ausführung), BR 250)
Beutel à 2 Stück
for trailing box coupling pocket
(E 44, BR 243, BR 119,
BR 01 (old type), BR 250), bag of 2

Art.-Nr: 08846 UVP in €: 3,85

Beutel à 20 Stück/bag of 20

Art.-Nr: 08849 UVP in €: 22,90



für Aufnahme der V 200 DR
Beutel à 2 Stück
for coupling pocket of V 200 DR
bag of 2

Art.-Nr: 08845 UVP in €: 3,85



für Schlitzaufnahme (E 94, V 36 (alte
Ausführung), V 60, BR 81, BR 92),
Zementsilowagen, BTTB-Modelle),
Beutel à 10 Stück
for slot mount (old design), cement
silo waggon, BTTB-models,
bag of 10

Art.-Nr: 08847 UVP in €: 13,90

Beutel à 50 Stück/bag of 50

Art.-Nr: 08848 UVP in €: 52,50

Alte Ausführungen/previous versions

Start-Kupplung, kurz, für
Schlitzaufnahme, Beutel à
50 Stück/Starter-Coupling,
short, for „Schlitzaufnahme“,
bag of 50



Art.-Nr: 08823 UVP in €: 39,90

Steifkupplung für Norm-
schacht, Beutel à 20 Stück
Formal-Coupling, for NEM
coupling pocket, bag of 20



Art.-Nr: 08827 UVP in €: 13,90

Start-Kupplung mit
Aufnahme für Norm-
schacht, Beutel à 10 Stück
Starter coupling for NEM
coupling pocket,
bag of 10



Art.-Nr: 08872 UVP in €: 14,50

Start-Kupplung mit Auf-
nahme für Kuppelkasten
Starter coupling for
trailing box
coupling pocket



Art.-Nr: 210190 UVP in €: 1,75

Start-Kupplung, lang,
für Schlitzaufnahme
Beutel à 50 Stück
Starter-Coupling, long,
for „Schlitzaufnahme“,
bag of 50



Art.-Nr: 08824 UVP in €: 39,90

Kurzkupplung ohne automat. Funktion mit Aufnahme
für Normschacht, Beutel à 20 Stück
Short distance coupling for NEM coupling pocket
(without automatic mode of operation), bag of 20



Art.-Nr: 08828 UVP in €: 13,90

Modellbahnsteuersystem für vorbildgerechten Fahrbetrieb Model railway control system for realistic operation

Schaltrelais/Zeitschalter – Switching relay/delay timer

Art.-Nr: 08415
UVP in €: 30,90



Dieses Relaismodul ersetzt die elektro-mechanischen Bausteine Relais und Zeitschalter (Art.-Nr.: 08410 und 08420) durch eine moderne elektronische Lösung. Die Besonderheit liegt darin, dass die Relais- und Zeitschalterfunktion in einem Modul integriert sind und über einen „Jumper“ vom Anwender gesteckt wird. Im Unterschied zu den Vorgängerbausteinen wird hier eine separate Stromversorgung benötigt, die aus jedem Zubehörtrafo (12 – 16 V) entnommen werden kann. Das Modul verfügt über 2 potentialfrei verwendbare Wechselkontakte mit einer maximalen Strombelastbarkeit von je 1 A. Die Steuereingänge „E“ und „A“ sind kurzschlussicher beschaltet, so dass nahezu jedes Steuersignal im Bereich von -16 V bis ca. +0,5 V zum Schalten führt. Sie sind auch zwischen mehreren Relaismodulen untereinander verschaltbar. Auf dem Modul befindet sich ein Stellpotentiometer, über das die Schaltverzögerung eingestellt wird (von ca. 2 Sek. bis ca. 5 Min.). Eine LED signalisiert den Schaltzustand „Relais aus“. Nach dem Bereitstellen der Versorgungsspannung geht das Modul automatisch in diese Vorzugsstellung (LED an).

This relay module replaces the previous electric-mechanical relay and delay timer, article numbers 08410 and 08420, with a modern electronic solution. The special feature of the new solution is the fact that relay and timer functions are integrated into a single module and can be defined by the user by means of a jumper. Unlike its predecessors, the new module requires a separate power supply, which can be taken from any accessory transformer (12 ... 16 V).

The module possesses two floating two-way contacts with a maximum current capacity of 1 A each. The control inputs „E“ and „A“ are configured to be short-circuit-proof, ensuring that almost any control signal in the range from -16 V to approx. +0.5 V results in switching. They can also be connected for interdependent switching between several relay modules. A setting potentiometer on the module is used to set the switching delay (range from approx. 2 sec. to approx. 5 min.). An LED signals the switching state „Relay OFF“. When the supply voltage is applied, the module always assumes this preferred state automatically (LED on).

Hinweis / Note: Schaltbeispiele siehe TILLIG-Gleis-Katalog/
Switching examples you find in our TILLIG track catalogue



Schaltrelais-Baustein
Switching relais

Art.-Nr: 08414
UVP in €: 26,50

Das vorliegende Relaismodul ersetzt das elektro-mechanische Relais, Art.-Nr. 08410, durch eine moderne elektronische Lösung in doppelter Ausführung.

Das Modul verfügt über je zwei potentialfrei verwendbare Wechselkontakte mit einer maximalen Strombelastbarkeit von je 1 A. Die Steuereingänge „1“ und „2“ sind kurzschlussicher beschaltet, so dass nahezu jedes Steuersignal im Bereich von -16 V bis ca. -8 V zum Schalten führt u. a. Tastenpult gegen Massepotential oder Wechselspannung geschaltet, Gleiskontakte an der Gleismasseseite ange-

bracht, Reedkontakte, Optokoppler usw. Sie sind auch zwischen mehreren Relaismodulen untereinander verschaltbar. Der jeweilig letzte Schaltzustand bleibt auch im stromlosen Zustand erhalten.

Einsatzmöglichkeiten des Bausteins:

- Wendezugautomatik
- Zwischenhalt
- Automatische Kehrschleifensteuerung
- Automatische Blocksteuerung
- Möglichkeit der Herzstückpolarisierung (z. B. Art.-Nr. 83230 Dreiwegeweiche) und der Weichenrückmeldung

The relay module at hand replaces the electric-mechanical relay (Art. No. 08410) with a modern electronic solution in duplicate.

The model has two potential-free adaptable changeover contacts with a maximum current carrying capacity of 1 A each. The control inputs “1” and “2” are wired to be short-circuit protected so that virtually any control signal in the range of -16 V to approx. -8 V leads to switching; among other things, key control console switched against common potential or alternating voltage, track contacts attached to the rail mass side, reed contacts, optical coupler, etc. They can also be interconnected between several relay modules. The respective last switching status is also preserved in a zero-current state.

Fields of application for the module:

- Automated push-pull train system
- Terminal station break
- Automatic terminal loop control, automatic block control
- Possibility of core (frog) polarisation (e. g. Art. No. 83230 Three-way Turnout) and turnout feedback

Werkzeug & Bastelmaterial / Tools & handicraft material

Mini-Holzschrauben zur Befestigung von Gleismaterial schwarz brüniert, 1,4 x 8 mm (100 St.)

Mini wood screws to fasten the tracks burnished black, 1,4 diameter x 8mm long (100 pcs./bag)



Art.-Nr: 08970 UVP in €: 8,50

Mini-Holzschrauben zur Befestigung von Gleismaterial schwarz brüniert, 1,4 x 15 mm (100 St.)

Mini wood screws to fasten the tracks burnished black, 1,4 diameter x 15mm long (100 pcs./bag)



Art.-Nr: 08976 UVP in €: 9,70

Getriebefett (5 g)
Transmission grease (5g/tin)



Art.-Nr: 08973 UVP in €: 5,00

Reinigungsdestillat, Flasche, 125 ml / Cleaning fluid, bottle, 125 ml

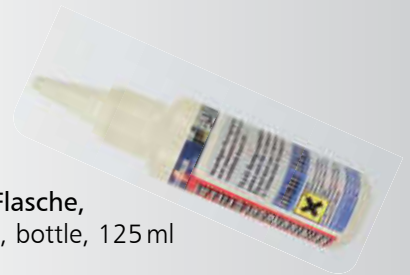

Art.-Nr: 08977 UVP in €: 8,50

Schaltlitze in rot, blau, schwarz und gelb (je 10 m)
Stranded hook-up wire in red, blue, black, yellow connection cable (each 10-m-length)



Art.-Nr: 08972 UVP in €: 9,70

Gleis-Reinigungsstein „Universal Schleifix“ (8 x 5 x 2 cm)

Track cleaning stone „Schleifix“ universal grinder (8 x 5 x 2 cm)



Art.-Nr: 08974 UVP in €: 9,10

Zubehör / Accessories

Handentkuppler
Manuel uncoupler



Art.-Nr: 07920 UVP in €: 4,50

Verteiler (Leiste zum Klemmen)
Distributor block (Strip for terminal)



Art.-Nr: 08931 UVP in €: 2,65

Kabelhalter (Leiste zum Klemmen)
Wire holder (Strip for terminal)



Art.-Nr: 08940 UVP in €: 0,95

Aufgleiser Modellgleis
Railer advanced track

Art.-Nr: 07910 UVP in €: 1,60



Aufgleiser Bettungsgleis
Railer bedding track

Art.-Nr: 07911 UVP in €: 1,60

(ohne Abb.)

Kontaktgarnitur, zum Auslösen von Schaltvorgängen durch den fahrenden Zug (nur für Standardgleis BTTB) / Contact set to trigger of switching actions by the train driving (only for BTTB standard track system)



Art.-Nr: 08430 UVP in €: 3,40

Lehre für Radsatz und Gleis für Spur TT 12 mm
Template for wheel set and track for gauge TT 12 mm



Art.-Nr: 08960 UVP in €: 11,50

Lehre für Radsatz und Gleis für 9 mm
Template for wheel set and track for 9 mm



Art.-Nr: 08961 UVP in €: 11,50



Spannungsprüfer, zur Feststellung der Polarität am Gleis (geeignet für Nenngröße TT, H0/H0e/H0m und N)
Charge indicator for the setting of the polarity at the track (ideal for gauge TT, H0/H0e/H0m und N)

Art.-Nr: 08419 UVP in €: 6,20

Zubehör

Haftreifen
Traction tyre



Haftreifen 14 mm,
Einsatz für BR 23/35, BTTB
(Beutel à 8 Stück)
Traction tyre 14 mm
for BR 23/35, BTTB
(bag of 8)

Art.-Nr: 08883 UVP in €: 6,20

Haftreifen 8 mm,
Einsatz für BR 01/119/
120/221/130, BTTB
(Beutel à 8 Stück)
Traction tyre 8 mm
for BR 01/119/120/221/
130, BTTB (bag of 8)

Art.-Nr: 08884 UVP in €: 6,20

Haftreifen 10,5 mm,
Einsatz für BR
56/250/243, E 44/94,
BTTB (Beutel à 8 Stück)
Traction tyre 10,5 mm
for BR 56/250/243, E44/94,
BTTB (bag of 8)

Art.-Nr: 08881 UVP in €: 6,20

Haftreifen 9,2 mm,
Einsatz für BR 110, BTTB
(Beutel à 8 Stück)
Traction tyre 9,2 mm
for BR 110, BTTB
(bag of 8)

Art.-Nr: 08882 UVP in €: 6,20

Kohlebürsten
Carbon brush



Kohlebürsten, eckig, Ein-
satz für runden Motor von
BTTB (Beutel à 10 Stück)
Carbon brush for round
motor of BTTB
(bag of 10)

Art.-Nr: 08875 UVP in €: 8,50

Kohlebürsten, rund, Ein-
satz für eckigen Motor
von TILLIG
(Beutel à 10 Stück)
Carbon brush, for square
Motor of TILLIG (bag of 10)

Art.-Nr: 08876 UVP in €: 6,90

Kohlebürsten für
Mashima MH 1224,
Einsatz für V 100
(Beutel à 10 Stück)
Carbon brush for Mashima
MH 1224 (diesel locomotive
V 100), (bag of 10)

Art.-Nr: 08870 UVP in €: 6,90

Kohlebürsten für
Mashima M 24-F 11,
Einsatz für BR 52
(Beutel à 10 Stück)
Carbon brush for Mashima
M 24-F 11 (steam locomotive
class 52), (bag of 10)

Art.-Nr: 08871 UVP in €: 6,90

Kohlebürsten „Bühler“
(Beutel à 10 Stück)
Carbon brush „Bühler“
(bag of 10)

Art.-Nr: 08877 UVP in €: 6,90

Zwerglampen
Miniature lamps



Zwerglampen 16V, kurzer
Kolben, Einsatz für BR 56/
86 BTTB (Beutel à 6 Stück)
Miniature lamps 16V, short
socket for BR 56/86 BTTB
(bag of 6)

Art.-Nr: 08874 UVP in €: 6,90

Zwerglampen 6V, Einsatz
für Eilzugwagen im
Analogbetrieb
(Beutel à 6 Stück)
Miniature lamps 6V, for fast
passenger trains in analogue
operating (bag of 8)

Art.-Nr: 08878 UVP in €: 6,90

Zwerglampen 10V,
Einsatz für BR 130/211,
BTTB; BR 01, E 94,
Einsatz für Eilzugwagen
im Digitalbetrieb
(Beutel à 6 Stück)
Miniature lamps 10V,
for BR 130/211, BTTB; BR
01, E 94, for fast passenger
trains in digital operating,
(bag of 6)

Art.-Nr: 08879 UVP in €: 6,90

Zwerglampen 16V,
langer Kolben, Einsatz
für BR 110, BTTB, E 94,
Eilzugpackwagen
(Beutel à 6 Stück)
Miniature lamps 16V, long
socket, for BR 110, BTTB,
E 94, fast passenger train
(bag of 6)

Art.-Nr: 08880 UVP in €: 6,90

Radsätze
Metal wheel set



Metallradsatz Ø 8,0 mm,
einseitig isoliert (Länge
18,6 mm/Beutel à 8 Stück)
Metal wheel set Ø 8,0 mm,
one wheel isolated
(length 18,6 mm/bag of 8)

Art.-Nr: 08819 UVP in €: 14,50



Metallradsatz Ø 8,0 mm
einseitig isoliert (Länge
18,6 mm/Beutel à 50 Stück)
Metal wheel set Ø 8,0 mm,
one wheel isolated
(length 18,6 mm/bag of 50)

Art.-Nr: 08820 UVP in €: 84,90



Metallradsatz Ø 7,5 mm
einseitig isoliert (Länge
18,6 mm/Beutel à 8 Stück)
Metal wheel set Ø 7,5 mm,
one wheel isolated
(length 18,6 mm/bag of 8)

Art.-Nr: 08818 UVP in €: 14,50



Speichenradsatz, beid-
seitig isoliert (Länge
18,6 mm/Beutel à 10 Stück)
Spoked wheel set,
both wheels isolated
(length 18,6 mm /bag of 10)

Art.-Nr: 08890 UVP in €: 26,90

NEU



Scheibenradsätze für Personen-/
Packwagen H0m (8 Stück)
Metal wheel set for passenger /
baggage coaches H0m (8 pcs.)

Art.-Nr: 08894 UVP in €: 21,80

Brücken und Pfeiler / Bridges and piers



Brückenpfeiler sandsteinfarben, Höhe 65 mm
 Bridge pier sandstone, 65 mm high

Art.-Nr: 07161 UVP in €: 2,00



Brückenpfeiler grau Höhe 65 mm
 Bridge pier grey, 65 mm high

Art.-Nr: 07160 UVP in €: 2,00



Brückenpfeiler grau Höhe 23,8 mm
 Bridge pier grey, 23,8 mm high

Art.-Nr: 07170 UVP in €: 1,70



Gitterbrücke ohne Gleis, Länge 115 mm
 Lattice bridge without track, length 115 mm

Art.-Nr: 07130 UVP in €: 3,85



Innenbeleuchtungsbausätze / Interior lighting kits

Innenbeleuchtungs-Bausatz Universal
 (In Kooperation mit Viessmann) /
 Interior universal lighting kit
 (in cooperation with Viessmann)

Art.-Nr: 08858

UVP in €: 26,50

- **Beleuchtungsstreifen mit variabler Länge (max. 210 mm, kürzbar)**
 Lighting strip with variable length (max. 210 mm, can be shortened)
- **Zur Nachrüstung aller Reisezugwagen, die für den Einbau einer Innenbeleuchtung vorbereitet sind/**For the retrofitting of all the railways carriages that are prepared for the installation of interior lighting
- **Warm-weiße LED-Beleuchtung/Warm-white LED lighting**
- **Betriebsspannung für Analog- und Digitalbetrieb bis 22 V geeignet/**Operating voltage suitable for analogue and digital operation up to 22 V
- **Stromaufnahme bei ungekürzter Länge max. 25 mA/**Power consumption with uncut length max. 25 mA
- **Hinweis: Dieser Bausatz ersetzt alle bislang von TILLIG angebotenen Innenbeleuchtungs-Bausätze/**Please note: This construction kit replaces all the interior lighting construction kits offered by TILLIG up to now

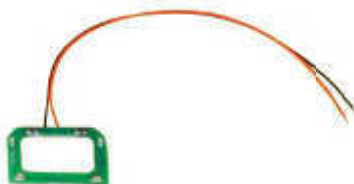

NEU

Zugschlußbeleuchtung (2 Stück) für Reisezugwagen Typ Y
 Rear lighting (2 pcs./bag) for passenger coaches type Y

Art.-Nr: 08856 UVP in €: 19,90



Nachrüstset Kontaktstreifen für Innenbeleuchtung
 Add-on-kit for interior lighting

Art.-Nr: 08869

UVP in €: 3,95

- **Zusatzteile zum Nachrüsten unserer neuen Innenbeleuchtung** Art. 08858 für Doppelstockeinzelwagen, Mod-Wagen, Halberstädter Mitteleinstiegswagen, Y- und Reko-Wagen (BTTB-Bauart)/
 Additional parts for the retrofitting of our new interior lighting art. 08858 for double deck single carriages. Modernisation carriages, Halberstädter centre entry carriages, Y and reconstructed carriages (Berliner TT Bahnen company – BTTB- models)



Innenbeleuchtung Aussichtswagen
 Interior lighting for passenger coach dom car

Art.-Nr: 08854 UVP in €: 27,90

NEU



Innenbeleuchtung „Buckelspeisewagen“
 Interior lighting for dining coach „Buckelspeisewagen“

Art.-Nr: 08855 UVP in €: 27,90

Dachstromabnehmer / Pantograph



Dachstromabnehmer für BR 189 (Wechselstromausführung Deutschland), passend auch für BR 101 und ICE
Pantograph (German AC type) for class 101, class 189 and ICE

Dachstromabnehmer für BR 189 (Wechselstromausführung Schweiz), passend auch für ICE schweizer Ausführung
Pantograph (Swiss AC type) for class 189 and ICE swiss



1 Paar Scheren-Dachstromabnehmer, rot, Einsatz für E 94/44, BR 250
Pair of double-arm pantograph (red) for E 94/44, BR 250

1 Paar Einholm-Dachstromabnehmer, rot, Einsatz für BR 243, BR 143/112
Pair of single-arm pantograph (red) for class 243, class 143/112

Art.-Nr: 08887 UVP in €: 16,90

Art.-Nr: 08888 UVP in €: 16,90

Art.-Nr: 08885 UVP in €: 21,90

Art.-Nr: 08886 UVP in €: 21,90

Gleisplan-CD / Track planning CD



CD-ROM 30 TT-Gleispläne von 1,60 – 3,00 m Länge (Standardgleis, Modellgleis, Bettungsgleis, inkl. Wintrack-Viewer), in Koop. mit Firma modellplan CD with track planning software, in cooperation with firm modellplan

CD-ROM 25 TT-Gleispläne von 3,00 – 5,00 m Länge (Standardgleis, Modellgleis, Bettungsgleis, inkl. Wintrack-Viewer), in Koop. mit Firma modellplan CD with track planning software, in cooperation with firm modellplan

Art.-Nr: 09548 UVP in €: 19,90

Art.-Nr: 09549 UVP in €: 19,90

TIPP: Planungs-Software „WINTRACK“

Erhältlich im Fachhandel oder direkt von modellplan:
Can be obtained from specialist dealers or directly from modellplan:
Reußensteinweg 4, 73037 Göppingen, Germany, www.modellplan.de



Modellumrüstset für Standardgleis-Weichenantrieb, er enthält alle Bauteile, um die Weichenantriebe getrennt von den Weichen oberflur oder unterflur anzubringen.
Kit for mounting model conversion set for standard track point drive, it contains all the component parts for the attachment of point drives separated by the surface mounted and underfloor mounted points.

Art.-Nr: 07960 UVP in €: 6,40



Elektrische Zugschlussbeleuchtung (für 4-achs. Rekowagen BTTB-Bauart)
Electrical rear light

Elektrische Zugschlussbeleuchtung (für 4-achs. Y-Wagen BTTB-Bauart)
Electrical rear light

Art.-Nr: 08814 A UVP in €: 5,30

Art.-Nr: 08815 A UVP in €: 5,30

Literatur / Literature



Anleitungsheft
„Ins richtige Gleis mit der
TT-Bahn“, in Koop. mit
dem Bradler-Verlag
Tutorial book „Into the right
track with the TT-Railway“,
in coop. with Bradler-Verlag

Art.-Nr: 09571 UVP in €: 9,90



Anleitungsheft
mit Vorlagen für
Gleispläne
Verlag G. Feuereißen
Tutorial book for track
planning, publisher
G. Feuereißen

Art.-Nr: 09602 UVP in €: 8,95

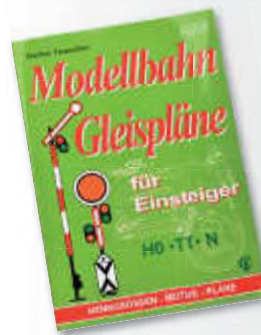

Anleitungsheft
„Gleispläne für
Einsteiger“
Verlag G. Feuereißen
Tutorial book for beginners,
publisher G. Feuereißen

Art.-Nr: 09601 UVP in €: 5,00



Anleitungsheft
„Elektrik für Einsteiger“
Verlag G. Feuereißen,
Tutorial book „Electric for
beginners“, publisher
G. Feuereißen

Art.-Nr: 09603 UVP in €: 7,00

TILLIG-Straßenbahngleis / TILLIG-Tram track system

Freunde der Straßenbahn werden begeistert sein vom genial einfachen Prinzip unseres TILLIG-Straßenbahngleises und -Bodenflächensystems. Mit diesem ist es möglich, Modell-Straßenbahnen in Modellbahnanlagen problemlos zu integrieren. Wir bieten es in den Größen Spur H0 (Spurweite 16,5 mm) und Spur H0m/TT (Spurweite 12 mm) an.

Friends of trams will be brim over with enthusiasm for brilliant and easy principle of the TILLIG-Tram track and -ground area system. It is trouble-free possible to integrate model trams in model train layouts. We offer this system in gauge H0 (16,5 mm) and also in gauge H0m/TT (12 mm).

Das TILLIG-Straßenbahngleis ist auch zum vorbildgetreuen Nachbau von Industrieanschlüssen hervorragend geeignet. With this tram track system it is possible to create interesting industrial areas to be found in real-life installations.



NEU

Planungsmappe Straßenbahngleis
Planning folder Tram track system

Art.-Nr: 09617 UVP in €: 12,90

Weitere Informationen
erhalten Sie unter:
www.tillig.com
und in unserem
TILLIG-Gleis-Katalog

Further information you
find under: www.tillig.com
and in our special TILLIG
catalogue for tracks

Art.-Nr: 09588 UVP in €: 3,50



In unserem Händlerverzeichnis unter www.tillig.com finden Sie alle TILLIG-Fachhändler im In- und Ausland.
On our website www.tillig.com you can find in the dealer list all TILLIG-Specialist dealers at home and abroad.

Africa/Asia/South America

Gulf-Hanseatic Trading and Engineering
Humboldtstraße 67a
22083 Hamburg/GERMANY
Tel.: (+49 40) 4294967-300
Fax: (+49 40) 4294967-311
mail@gulf-hanseatic.com
www.gulf-hanseatic.com

Australia

Orient Express Model Railway Shop
2 King William Road
5061 Unley/AUSTRALIA
Tel.: (+61) 882717861
Fax: (+61) 883731961
sales@orientexpressmodels.com.au
www.orientexpressmodels.com.au

Belgium/France /Luxembourg

Train Service Danckaert bvba
Patrick Danckaert
Hamiltonpark 14
8000 Brügge/BELGIUM
Tel./Fax: (+32) 50311835
tsd@tsdbvba.be
www.modeltrainservice.com

Bulgaria

Hobby strong EOOD
ul. „T. Kableschkov“ N°3
Magazin „Hobi swiat“
1618 Sofia/BULGARIA
Tel.: (+359) 888283954
hobbystrong@abv.bg
www.hobbystrong.com

Canada

Eurobahn Ottawa
150 MacLaren Street, Unit 116
Ottawa, Ontario K2P 0L2/CANADA
Tel.: (+1) 6132340407
info@eurobahn-ottawa.ca
www.eurobahn-ottawa.ca

Czech Republik

David Strupp
Erbenova 2906
47001 Ceska Lipa/CZECH REPUBLIK
Tel.: (+420) 776866306
zastupce@tilligcz.cz

España/Andorra/Portugal

Sra. Isabel Aguilo Llobera
Via Augusta 7
08950 Esplugues de Llobregat
Barcelona/ESPANA
Tel.: (+34) 934990529
Fax: (+34) 933940935
trenes-aguilo@infonegocio.com
www.trenes-aguilo.com

Great Britain

Golden Valley Hobbies Ltd.
Unit 1, Pontrilas Business Park,
Pontrilas, Herefordshire, HR2 0AZ |
Great Britain
Tel.: (+44) 1981 241237
info@goldenvalleyhobbies.com
www.goldenvalleyhobbies.com

Hong-Kong/China

Lee Kwon Hobbies Company
Wong Hin, Leo/Shop A, G/F
Wing Sing Build.,
30-40 Temple St.
Yaumatei, Kowloon/HONG-KONG
Tel.: (+852) 23975719
Fax: (+852) 23970455
leo@leekwon.com.hk

Italy

Doc Models
Via Don Minzoni, 26
12011 Borgo San Dalmazzo (CN)/
ITALY
Tel.: (+39) 171261900
Fax: (+39) 171261908
info@docmodels.com
www.docmodels.com

Netherlands

Burgt Eurotrein
Kabelstraat 18
5612 NL Eindhoven/NETHERLANDS
Tel./Fax: (+31) 402453408
eurotrein@planet.nl
www.eurotrein.eu

Poland

AMC Biuro Handlowo-Uslugowe
Teczowa 83
53601 Wroclaw/POLAND
Tel./Fax: (+4871) 3428744
amc@amcwroclaw.pl
www.amcwroclaw.pl

Russia

SEMAPHOR
Prospekt Mira 72
Moscow/RUSSIA
Tel.: (+7) 0952583897
Fax: (+7) 0952583899
info@semaphor.ru
www.semaphor.ru

Slovakia

Händleradressen über: David Strupp
(siehe Czech Republik)

South Africa

Model Train Exchange
Whitecliffs, 5 Dover Street
2125 Ferndale/Randburg/SOUTH
AFRICA
Tel./Fax: (+27) 117876121
info@mte.co.za
www.mte.co.za

Switzerland

KML GmbH
Balgacherstrasse 14
9445 Rebstein/SWITZERLAND
Tel.: (+41) 717759010
Fax: (+41) 717759019
info@kml-log.ch
www.kml-log.ch







USA









REYNAULD'S EURO IMPORTS INC.
122 N. Main Street
60119 Elburn, Illinois/USA
Tel.: (+1) 6303656340
Fax: (+1) 6303656345
info@reynaulds.com
www.reynaulds.com

Lokomotiven / Locomotives

Bezeichnung	Seite	Bezeichnung	Seite	Bezeichnung	Seite
	BR 01.5 DR, Ep. III 02004 25		BR 84 DRG, Ep. II 02191 19		MY 1149, Altmark-Rail, Ep. VI 04536 112
	BR 01.5 DR, Ep. IV 02005 38		BR 86, DRG, Ep. II 02181 19		M 61 MAV, Ep. IV 04535 153
	BR 01 DR, Ep. IV 02135 25		BR 86, DR, Ep. III 02179 26		M 61 MAV, Ep. IV – Sound 92654 153
	BR 01 DR, Ep. IV 02130 38		BR 86 DB, Ep. IV 02178 74		CFL, Ep. IV 04537 168
	BR 001 DB, Ep. IV 02133 74		Reihe 455.2, ČSD, Ep. III 02180 126		BR 280, DB, Ep. IV 04801 75
	BR 03.2 DR, Ep. III 02145 25		BR 95, DR, Ep. III 03010 27		V100.10, DB, Ep. III 501351 60
	BR 03.2 DR, Ep. IV 02146 39		BR 95, DR, Ep. IV 03011 39		BR 219 DB, Ep. IV 02741 75
	BR 23.0 DRG, Ep. II 02101 18		V36, DB, Ep. III 04637 60		BR 218 MEG, Ep. VI 02715 111
	BR 23.10 DR, Ep. III 02051 25		T 334.0 ČSD, Ep. III 04635 127		V 200 DB, Ep. III 02501 60
	P8 K.P.E.V., Ep. I 02022 16		V 60.10-11 DR, Ep. III 96112 27		BR 220 DB, Ep. IV 02503 75
	BR 38.10, DRG, Ep. II 02023 18		V 60 DR, Ep. III 96156 27		BR 220 DB, Ep. IV 02500 75
	BR 38.10 DR, Ep. III 02020 26		BR 106 DR, Ep. IV 96151 39		D20 BEG, Ep. VI 04510 111
	BR 38.10 DR, Ep. III – Sound 92653 26		V 60D, Leuna, Ep. III 96114 110		V270 SGL, Ep. VI 04511 112
	BR 38.10 DR, Ep. IV 02025 38		BR 346, DB AutoZug, Ep. VI 96154 113		Am 4/4 SBB, Ep. IV 02505 160
	BR 038 DB, Ep. IV 02021 74		BR 345, ITL, Ep. VI 96155 113		BR 245, DB AG, Ep. VI 04940 87
	Reihe Ok1 PKP, Ep. III 02026 121		T 435 KEG, Ep. V 04629 113		BR 285 Express-Rail, Ep. VI 04934 112
	Reihe 377.0, ČSD, Ep. III 02024 126		T 435 ČSD, Ep. III 04621 127		BR 285 RheinC., Ep. VI 04935 112
	BR 50 DRG, Ep. II 02094 19		T 435 ČSD, Ep. IV 04627 131		Reihe 650 LOTOS, Ep. VI 04937 124
	BR 50 DR, Ep. IV 02096 39		ChME2, SZD, Ep. IV 04628 145		T 334 Werklok, Ep. III 04616 110
	BR 50 DB, Ep. III 02097 60		V 100 DR, Ep. III 02582 27		T 334 ČSD, Ep. III 04611 127
	BR 050 DB, Ep. IV 02295 74		BR 110 DR, Ep. IV 04589 40		T 334 ČSD, Ep. III 04615 127
	Reihe Ty5 PKP, Ep. III 02095 121		BR 202 DB AG, Ep. V 04588 87		T 334 ČSD, Ep. IV 04614 131
	BR 555.1 ČSD, Ep. III 02299 126		V100 SETG, Ep. VI 04590 113		VT 137 / VS 145, DRG, Ep. II 02854 21
	BR 52 DR, Ep. III 02287 26		V 180 DR, Ep. III 02691 28		VT 137 / VS 145, DR, Ep. III 02850 29
	BR 52 Museumslok, Ep. VI 02289 111		BR 118 DR, Ep. IV 02693 40		VS 145, DR, Ep. III 13301 28
	Rh 52 ÖBB, Ep. III 02285 146		BR 119, DR, Ep. IV 02780 47		
	Reihe 26 SNCB, Ep. III 02288 168		BR 229, DB AG, Ep. V 02791 86		
	G8.2, K.P.E.V., Ep. I 02165 16		BR 219, DB AG, Ep. V 02792 86		
	BR 56.20, DRG, Ep. II 02166 19				
	BR 56 DR, Ep. III 02160 26				

Lokomotiven / Locomotives

Bezeichnung	Seite
 BR 642 DB AG, Ep. VI	02881 87
BR 642 DB AG, Ep. VI	02882 87
BR 642 Städtebahn, Ep. VI	02885 111
 BR 101 DB AG, Ep. VI	02314 88
BR 101 DB AG, Ep. VI	02315 88
 E 10.12 DB, Set, Ep. III	01614 62
BR 139, DB, Ep. IV	02397 76
BR 115, DB Autoz., Ep. VI	02391 89
BR 139, DB AG, Ep. V	02395 89
 E 40, DB, Ep. III	02394 61
BR 140, DB AG, Ep. V	02390 89
BR 110, PRESS, Ep. VI	02398 114
BR 140, EVB, Ep. VI	02399 114
 BR 146.5, DB AG, Ep. VI	04909 90
 Reihe 183 AWT, Ep. VI	04964 116
BR 370 PKP-Intercity, Ep. VI	04953 124
1216 ČD Railjet, Ep. VI	04962 136
Rh 1216 ÖBB, Ep. VI	04952 150
1216 STB, Ep. VI	04956 152
 Reihe 482, „Infraleuna“, Ep. VI	501323 110
BR 186 CAPTRAIN, Ep. VI	04910 115
BR 186 RAILPOOL, Ep. VI	04911 115
BR 186 EURO CARGO RAIL, Ep. VI	04912 115
BR 186 METRANS, Ep. VI	04915 115
Reihe 480, MAV, Ep. VI	04908 155
E 186, SBB Cargo, Ep. VI	04907 161
Reihe 28, SNCB, Ep. VI	04906 170

Bezeichnung	Seite
 BR 189 MTEG, Ep. VI	02478 114
BR 189 MRCE, Ep. VI	02484 114
EU 45 PKPCargo, Ep. VI	02486 124
 E 18 DRG, Ep. II	02453 20
E 18 DR, Ep. III	02454 28
E 218 DR, Ep. IV	02450 40
E 18 DB, Ep. III	02457 61
BR 118 DB, Ep. IV	02451 76
BR 118 DB, Ep. IV	02455 76
1118.01 ÖBB, Ep. III	02452 146
 BR 211, DR, Ep. IV	501067 41
BR 242, DR, Ep. IV	501357 42
BR 142, EGP, Ep. VI	501350 116
 BR 243 DR, Ep. IV	02375 41
BR 143 DB AG, Ep. VI	02379 88
 BR 250 DR, Ep. IV	02337 41
 BR 252, DR, Ep. IV	04990 41
BR 156, MEG, Ep. VI	04991 116
 BR 401 DB AG, Set, Ep. VI	01353 90
DB AG, Set, Ep. VI	01611 91
DB AG, 1. Klasse, Ep. VI	13779 91
DB AG, Set, Ep. VI	01612 92
DB AG, 2. Klasse, Ep. VI	13780 92
 START-Diesellok BR 203	04598 173
 START-Diesellok BR 218	02709 174

Bezeichnung	Seite
Personenwagen / Passenger coaches	
 Abteilmwagen 3achsiger K.P.E.V., Set, Ep. I	01682 16
K.P.E.V., 3. Klasse, Ep. I	13149 16
K.P.E.V., Gepäck., Ep. I	13455 17
DRG, Gepäck., Ep. II	13411 20
DRG, Gepäck., Ep. II	13412 29
ÖBB, Gepäck, Ep. III	13417 147
 Personenwagen, 2-achsiger DRG, 3. Klasse, Ep. II	13208 20
DRG, 2. Klasse, Ep. II	13005 20
DR, 2. Klasse, Ep. III	13001 29
DR, 2. Klasse, Ep. III	13010 29
DB, Behelfsgepäck, Ep. III	16001 65
ČSD, 2. Klasse, Ep. III	13009 128
ČSD, 2. Klasse, Ep. III	13018 128
ÖBB, 1./2. Klasse, Ep. III	13004 147
ÖBB, 2. Klasse, Ep. III	13008 147
ÖBB, 2. Klasse, Ep. III	13017 147
 Postwagen DRG, Deutsche Reichspost, Ep. II	13891 22
ČSD, Ep. III	13892 128
 Schürzenwagen DRG, Set, Ep. II	01617 21
DRG, 1./2. Klasse, Ep. II	16923 22
DR, 1. Klasse, Ep. III	16900 30
DR, 1./2. Klasse, Ep. III	16920 30
DR, 2. Klasse, Ep. III	16940 30
DR, Speisewagen, Ep. III	16970 31
DR, Schlafwagen, Ep. III	16960 31
DB, Set, Ep. III	01595 64
DB, Speisewagen, Ep. III	16975 64
DB, 1./2. Klasse, Ep. III	16922 64
ÖBB, Set, Ep. III	01596 146
 m-Reisezugwagen, 4-achsiger RTC, Set, Ep. III	01693 65
DB, 1. Klasse, Ep. III	13518 66
DB, Sitz-/Gepäckw., 2. Kl., Ep. III	13519 66
DB, Liegewagen, Ep. III	16581 66
DB, Set, Ep. III	01623 67
USTC, Ep. IV	01692 77

Personenwagen / Passenger coaches

Bezeichnung	Seite	Bezeichnung	Seite	Bezeichnung	Seite	
DB, 2. Klasse, Ep. IV	13526	77		DR, Sitz-/Gepäckw. 2. Klasse, Ep. IV	16696	47
DB, Liegewagen, Ep. IV	16580	79		DR, 1. Klasse, Ep. IV	16660	47
DB AG, IR, 1. Klasse, Ep. V	13522	94		DR, Liegewagen 2. Klasse, Ep. IV	16650	47
DB AG, IR, 2. Klasse, Ep. V	13523	94		DR, 2. Klasse, Ep. IV	16652	47
DB AG, IR, 2. Klasse, Ep. V	13524	94		DR, 1./2. Klasse, Ep. IV	16661	47
DB AG, IR, Bistro, Ep. V	13525	94		DB AG, Set, Ep. V	01699	93
				DB AG, Schlafwagen, Ep. V	16724	95
Eilzugwagen, 4-achsiger				PKP, 2. Klasse, Ep. IV	16642	123
DRG, Gepäck, Ep. II	13827	22		PKP, Schlafwagen, Ep. IV	16722	123
DB, Ep. IV	13315	77		PKP, 2. Klasse, Ep. VI	16662	125
				PKP, Schlafwagen, Ep. VI	16727	125
Reisezugwagen, 4-achsiger, Silberling				ČSD, Sitz-/Gepäckw., 2. Klasse, Ep. IV	16697	131
DB, Steuerwagen, Ep. III	13830	67		ČSD, 2. Klasse, Ep. IV	16651	131
DB, 1./2. Klasse, Ep. III	13851	67		ČSD, 1. Klasse, Ep. IV	16647	132
DB, 2. Klasse, Ep. III	13850	67		ČSD, 1./2. Klasse, Ep. IV	16643	132
DB, 1./2. Klasse, Ep. IV	13857	80		ČSD, 2. Klasse, Ep. IV	16640	132
DB, 2. Klasse, Ep. IV	13856	80		ČSD, Weitstreckenschlafwagen, Ep. IV	16701	132
DB, 2. Klasse, Ep. IV	13863	80		ČD, Schlafwagen, Ep. V	16725	134
DB AG, 2. Klasse, Ep. VI	13864	96		ČD, Liegewagen, Ep. V	16667	134
				ČD, 1./2. Klasse, Ep. V	16653	134
IC-Reisezugwagen, 4-achsiger				ČD, 2. Klasse, Ep. V	16656	135
DB, Rheingold-Set, Ep. III	01614	62		ČD, 2. Klasse, Ep. V	16668	135
DB, 1. Klasse, Ep. III	13587	62		ČD, Schlafw., Ep. VI	16730	136
DB, Rheingold-Set, Ep. III	01651	63		ČD, 1. Klasse, Ep. VI	16645	137
DB, 1. Klasse, Ep. IV	13574	78		ČD, 1./2. Klasse, Ep. VI	16657	137
DB, 1. Klasse, Ep. IV	13584	78		ČD, 2. Klasse, Ep. VI	16646	137
DB, 1. Klasse, Ep. IV	13530	79		ČD, Liegewagen, Ep. VI	16663	137
DB, 2. Klasse, Ep. IV	16500	79		ČD, 2. Klasse, Ep. VI	16664	137
DB, 1. Klasse, Ep. IV	16503	79		ČD, Sitz-/Gepäckw. 2. Klasse, Ep. VI	16695	138
DB, 2. Klasse, Ep. IV	16506	80		ČD, Schlafwagen, Ep. VI	16705	139
DB, 2. Klasse, Ep. IV	16507	80		ČD, Schlafwagen, Ep. VI	16728	139
DB AG, Set, Ep. V	01704	95		ZSSK, 1./2. Klasse, Ep. VI	16658	143
DB AG, Ep. VI	16504	97		ZSSK, 2. Klasse, Ep. VI	16659	143
DB AG, Set, Ep. VI	01657	97		ZSSK, Sitz-/Gepäckw. 2. Klasse, Ep. VI	16698	143
DB AG, 2. Klasse, Ep. VI	16533	98		ZSSK, Weitstreckenschlafwagen, Ep. VI	16704	143
DB AG, 2. Klasse, Ep. V	16501	98		ZSSK, Schlafwagen, Ep. VI	16729	143
DB AG, Steuerw., Ep. VI	13565	98		SZD, Weitstreckenschlafwagen, Ep. IV	16700	145
DB AG, 1. Klasse, Ep. V	13586	98		RZD, Weitstreckenschlafwagen, Ep. VI	16703	145
DB AG, 1. Klasse, Ep. V	16100	98		MAV, Schlafwagen, Ep. IV	16721	153
DB AG, 2. Klasse, Ep. V	16582	99		MAV, 2. Klasse, Ep. IV	16641	154
DB AG, BordBistro, Ep. V	13528	99		MAV, 1. Klasse, Ep. IV	16665	154
DB AG, Steuerw., Ep. VI	13564	100		MAV, Schlafwagen, Ep. V/VI	16726	155
DB AG, „Snack Point“, Ep. VI	16505	100		OSE, Set, Ep. IV	01697	159
DB AG, 1. Klasse, Ep. V	13571	100				
DB AG, 1. Klasse, Ep. V	13576	100				
DB AG, 2. Klasse, Ep. V	16502	101				
DB AG, 2. Klasse, Ep. VI	16535	101				
DB AG, 2. Klasse, Ep. V	13581	101				
ARRIVA, 1./2. Klasse, Ep. VI	13582	116				
EC-Reisezugwagen, 4-achsiger						
PKP, 1. Klasse, Ep. VI	13536	124				
PKP, 2. Klasse, Ep. VI	13553	125				
ČD, Set, Ep. VI	01659	136				
ČD, 2. Klasse, Ep. VI	16534	136				
ČD, 1. Klasse, Ep. V/VI	16520	138				
ČD, 2. Klasse, Ep. V/VI	16530	138				
ČD, 2. Klasse, Ep. VI	16532	138				
ÖBB, 1. Klasse, Ep. VI	13541	149				
ÖBB, 2. Klasse, Ep. VI	13558	149				
ÖBB, 1. Klasse, Ep. VI	13535	151				
ÖBB, 2. Klasse, Ep. V/VI	13550	151				
ÖBB, Kinderkino Ep. V/VI	13555	151				
ÖBB, 2. Klasse, Ep. V/VI	16531	151				
JZ, 2. Klasse, Ep. V	16509	158				
SBB, 1. Klasse, Ep. IV	13539	160				
SBB, Liegewagen, Ep. IV	13556	160				
SBB, 1. Klasse, Ep. V/VI	13532	163				
SBB, Liegewagen, Ep. VI	13551	163				
FS, 1. Klasse, Ep. IV	13538	164				
FS, 2. Klasse, Ep. IV	13552	164				
SNCB, 1. Klasse, Ep. IV	13537	169				
SNCB, 2. Klasse, Ep. IV	13554	169				
						
E5-Wagen						
DR, 2. Klasse, Ep. III	13887	30				
DR, Set, Ep. IV	01658	42				
DR, 2. Klasse, Ep. IV	13888	42				
DR, Steuerwagen, Ep. IV	13873	46				
DR, 2. Klasse, Ep. IV	13879	46				
DR, 2. Klasse, Ep. IV	13889	46				
						
Rekowagen, 4-achsiger						
DR, Sitz-/Gepäckw., 2. Kl., Ep. III/IV	16600	38				
DR, 2. Klasse, Ep. IV	16621	42				
DB AG, 2. Klasse, Ep. V	16620	93				
DB AG, Sitz-/Gepäckw., 2. Kl., Ep. V	16601	93				
						
Reisezugwagen, Typ B, Y, Y/B 70, 4-achsiger						
DR, 1. Klasse, Ep. III	16301	31				
DR, 2. Klasse, Ep. III	16341	31				
DR, Autoreisezug, Ep. IV	01660	43				
DR, Autoreisezug, Ep. IV	01661	43				
DR, Tourex, Ep. IV	01662	44				
DR, Tourex, Ep. IV	01698	44				

Personenwagen / Passenger coaches

Bezeichnung Seite



Halberstädter Mitteleinstiegswagen
 DR, 2. Klasse, Ep. IV 13593 46
 MAV, 2. Klasse, Ep. VI 13592 155
 MAV, Set, Ep. VI 01625 155
 GYSEV, Set, Ep. VI 01688 158



Halberstädter Seitengangwagen
 DR, Set Städte-Ex, Ep. IV 501287 45
 DR, 1. Klasse, Ep. IV 501409 45
 DR, 1./2. Klasse, Ep. IV 501410 45
 DR, 2. Klasse, Ep. IV 501411 45
 DR, IR-Set, Ep. V 501286 59
 DB AG, 2. Klasse, Ep. V 501279 99
 DB AG, 2. Klasse, Ep. V 501349 99
 DB AG, Set Systemtechnik, Ep. VI 01686 101



Doppelstock-Einzelwagen
 DB AG, Steuerwagen, Ep. VI 13802 96
 DB AG 1./2. Klasse, Ep. VI 13803 96
 DB AG 2. Klasse, Ep. VI 13800 96
 SBB 1./2. Klasse, Ep. VI 13807 162
 SBB Set, Ep. VI 01666 162



Aussichtswagen
 DB, Ep. IV 16551 78



Speisewagen WRg
 DR, Speisewagen, Ep. IV 16750 46



Speisewagen WRm / WRmh
 DB, Set, Speisew., Ep. III 01623 67
 DB, Speisewagen, Ep. IV 13697 77
 DB, TEE-Speisewg., Ep. IV 16590 78



Gepäckwagen
 DRG, Ep. II 13423 20
 DR, Ep. IV 13426 49
 DB, Ep. III/IV 13476 65
 ÖBB, Ep. III 13456 147
 ÖBB, Ep. III 13475 148

Bezeichnung Seite



Start-Personenwagen, 2-achsig
 Speisewagen MITROPA 13239 173
 Personenwagen 13228 173



Start-Personenwagen, 4-achsig
 1. Klasse, IC 13625 174
 2. Klasse, IC 13626 174
 BD, IC 13609 174
 Speisewagen, IC 13759 174

Güterwagen / Freight cars



Güterwagen-Sets
 div., off. Güterw., Ep. I 01719 17
 DRG, div. Güterw., Ep. II 01673 22
 DR, Set, Ep. III 01683 32
 DR, Set, Ep. III 01684 33
 DR, Set, Ep. III 01711 33
 DR, Set Panzertransport, Ep. IV 01675 35
 DR, div. Güterwagen, 2-achsig, Ep. III 01642 37
 DR, Panzertransport, Ep. III 01627 37
 DR, div. Güterwagen, 2-achsig, Ep. IV 01643 49
 DR, Postzug, Ep. IV 01671 50
 DR, Militärtransport, Ep. IV 01712 50

DR, Bauzug, Ep. IV 01705 52
 DB, Bauzug, Ep. III 01664 72
 DB, div. Güterwagen, 2-achsig, Ep. III 01644 73
 DB AG, Standardhilfszug, Ep. V 01626 105
 PKP, Set Militärtransport, Ep. III 01674 121
 PKP, div. Güterwagen, 2-achsig, Ep. III 01646 122
 ČSD, div. Güterwagen, 2-achsig, Ep. III 01645 129
 ČSD, Panzertransport, Ep. III 01628 129



Niederbordwagen/Rungenwagen, 2-achsig
 K.P.E.V., Ep. I 14628 17
 Bad.St.B., Ep. I 14632 18
 DRG, Ep. II 14658 24

Bezeichnung Seite

DB, mit Beladung, Ep. III 14923 70
 DB, mit Beladung, Ep. IV 14924 82
 ČSD, Ep. III 14922 129
Start-Modell 14649 174



Niederbordwagen/Rungenwagen 4-achsig
 DR, mit Beladung, Ep. IV 18101 56
 DR, Ep. IV 15581 56
 DB, mit Beladung, Ep. IV 15568 83
 DB, mit Beladung, Ep. IV 18151 83
 DB, mit Beladung, Ep. IV 18152 83
 DB AG, mit Beladung, Ep. V 15569 107
 DB AG, mit Beladung, Ep. VI 18107 107
 PKPCargo, Ep. VI 18109 125
 ČD, Ep. V 15571 135
 ZSSK, Ep. VI 18110 144
 ÖBB, m. Beladung, Ep. VI 18108 152
 MAV, Ep. V 18105 156
 SBB, Ep. V 15587 160
 HUPAC, mit Beladung, Ep. V 18150 161
 SNCF, mit Beladung, Ep. VI 18100 170



Containertragwagen, 4-achsig
 DR, Ep. IV 18102 56



Doppeltragwagen
 DB AG, Ep. V 18001 108
 DB AG, mit Beladung Ep. V 18003 108
 DB AG, mit Beladung Ep. V 18030 108
 ÖBB, Ep. V 18002 150
 ÖBB, mit Beladung Ep. V 18004 150



Schwerlastwagen, 6-achsig
 DB, Ep. IV 15610 83

Güterwagen / Freight cars

Bezeichnung Seite



Offene Güterwagen, 2-achsig

K.Sächs.Sts.E.B., Ep. I	14284	18
K.Bay.Sts.B., Ep. I	14285	18
DRG, Ep. II	14282	23
DR, Ep. III	14283	34
DR, Ep. IV	17242	49
DB, Ep. III	17245	69
DB, Ep. IV	17243	84
PKP, Ep. III	14277	121
PKP, Ep. IV	17244	123
ČSD, Ep. III	14276	129
ČD Cargo, Set, Ep. VI	01716	140
ČD, Ep. VI	17253	142
ÖBB, Ep. III	14278	148
MAV, Ep. III	17250	153
GYSEV, Ep. IV	17252	157
FS, Ep. III	17251	164
SNCF, Ep. III	17247	165
SNCB, Ep. III	17248	168
SNCB, Ep. III	17249	168
Start-Modell	14269	174



Offene Güterwagen, 4-achsig

DR, Ep. IV	15246	53
DB AG, Ep. V	15650	104
DB AG, Set, Ep. VI	01677	104
DB AG, Set, Ep. V	01678	105
DB AG, Ep. V	15247	105
VTG, Ep. VI	15259	120
On Rail, Ep. VI	15652	120
ČSD, Ep. IV	15250	133
AWT, Ep. VI	15250	133
ÖBB, Ep. VI	15248	152
MAV, Ep. IV	15256	154
SBB, Ep. IV	15255	160
MAV-Cargo, Ep. VI	15262	156
Gysev, Ep. VI	15257	157
SNCF, Ep. IV	15258	165
SNCF, Ep. VI	15261	167



Gedeckte Güterwagen, 2-achsig

DRG, Ep. II	14126	24
DR, Ep. III	17132	35
DR, Ep. III	95215	36
DR, Ep. III	95291	36
DR, Set, Ep. IV	01631	51
DR, Ep. IV	17164	55
DR, Set „Leuna“, Ep. IV	501324	58
DB, Ep. III	17150	69
DB, Ep. III	17155	69

Bezeichnung Seite

DB, Ep. III	17156	69
DB, Set, Ep. III	01652	72
DB, Ep. IV	17162	84
DB AG, Ep. V	17154	102
DB AG, Ep. V	17158	103
DB AG, Ep. V	17163	103
PKP, Ep. III	95212	122
PKP, Ep. V/IV	17160	123
ČSD, Ep. III	17133	130
ČSD, Ep. III	17137	130
ČSD, Ep. III	95211	130
ČSD, Ep. IV	17151	133
ČSD, Ep. IV	95214	133
ČD, Ep. V	17159	135
ÖBB, Ep. III	95213	148
MAV, Ep. IV	17152	154
GYSEV, Ep. III	95216	157
SBB, Ep. III	14127	159
SNCB, Ep. IV	17136	169
NS, Ep. III	17135	170
Start-Modell	14117	174



Gedeckte Güterwagen, 4-achsig

DR, Ep. III	15115	35
-------------	-------	----



Kühlwagen, 2-achsig

DRG, Ep. II	17001	24
DR, INTERFRIGO, Ep. IV	14694	55
DR, Ep. IV	14690	55
DB, Ep. III	14110	68
DB, Ep. III	17002	68
DB, Ep. III	17134	70
DB, Ep. IV	14691	85
DB, Set, Ep. IV	01630	85
PKP, Ep. III	17003	121
ČSD, Ep. IV	14695	133
ČD Cargo, Ep. VI	14693	141
ÖBB, Ep. III	17004	148
DSB, Ep. III	14109	171
Start-Modell	14148	174



Schotterwagen

DRG, Ep. II	501285	23
DR, Ep. III	501273	36
DB, Ep. III	17500	69
PKP, Ep. III	17501	122
ČSD, Ep. III	17502	129



Selbstentladewagen, 2-achsig

DR, Ep. IV	14587	52
------------	-------	----

Bezeichnung Seite

DB, Ep. IV	14586	68
DB, Ep. IV	14585	84
DB AG, Ep. VI	14588	106
PRESS, Set, Ep. VI	01679	117
PRESS, Ep. VI	14589	117



Selbstentladewagen, 4-achsig

DR, Ep. IV	15283	53
DB, Set, Ep. III	01710	73
DB, Ep. IV	15170	84
DB AG, Ep. V	15281	106
PKP Cargo, Ep. VI	15280	125
ČD Cargo, Ep. VI	15298	141
MAV, Ep. VI	15300	156
SNCF, Ep. III	15171	165



Schüttgutwagen, 4-achsig

DR, Ep. IV	15370	53
DB AG, Ep. V	15371	106



Schwenkdachwagen 2-achsig

DR, Ep. IV	14571	51
DR, Ep. IV	14574	52
DR, Ep. IV	17153	55
DB, Ep. III	14576	68
ČD Cargo, Ep. VI	14577	141
EEWS, Ep. VI	14578	144
ÖBB, Ep. VI	14575	152
SBB, Ep. V	14591	161
SBB, Ep. VI	14579	163



Schwenkdachwagen, 4-achsig

DR, Ep. IV	15350	53
DB AG, „Getreide“, Ep. V	15351	107
DB AG, „SKW Piesteritz“, Ep. V	15352	107
NACCO, Ep. VI	15354	119
MAV, Ep. VI	15353	156



Kesselwagen, 2-achsig

DRG, Ep. II	17302	23
DRG, Ep. II	17303	23
DRG, Ep. II	95835	23
DRG, Ep. II	14980	24
DRG „NITAG“, Ep. II	95832	24
DRG, Ep. II	95838	24
DR, Ep. III	14981	35

Güterwagen / Freight cars

Bezeichnung	Seite
DR, Ep. III	95833 37
DR, Ep. III	95836 37
DR, Ep. IV	17401 57
DR, Ep. IV	95847 57
DB, Ep. III	17304 71
DB, Ep. III	95830 71
DB, Ep. III	95839 71
DB, Ep. III	95846 71
DB, Ep. IV	14479 81
DB, Ep. IV	14996 81
DB, Ep. IV	95840 81
VTG, Ep. VI	14971 117
On Rail, Ep. VI	14972 117
NACCO, Ep. VI	14995 118
GATX, Ep. VI	14999 118
PKP, Ep. III	95834 122
ČSD, Ep. III	14982 130
ČSD, Ep. III	17301 130
ÖBB, Ep. III/IV	17300 148
SBB, Ep. III	95842 159
SNCF, Ep. III	95843 165
CFL, Ep. III	95844 168
NS, Ep. IV	17402 170
DSB, Ep. III	17400 171
DSB, Ep. III	95837 171
DSB, Ep. III	95841 171
DSB, Ep. III	95845 172
SJ, Ep. III	17305 172
SJ, Ep. IV	14998 172



Kesselwagen, 4-achsrig

DR, Ep. IV	15431 56
GATX, Ep. VI	15469 118
ERMEWA, Ep. VI	15473 118
ČD Cargo, Ep. VI	15471 141
RYKO Ep. VI	15480 142
GYSEV, Ep. V	15475 157
GYSEV, Ep. VI	15467 157
VTG, Ep. VI	15479 164
SNCF, Ep. IV	15476 166
SNCF, Ep. IV	15477 166
SNCF, Ep. IV	15433 166
MILLET, Ep. VI	15474 167
RENFE, Ep. V	15432 167
VTG, Ep. VI	15478 170

Bezeichnung	Seite
	
Gaskesselwagen, 4-achsrig	
DR, Set, Ep. IV	01718 57
DR, Ep. IV	15000 57
DB, Ep. III	15002 71
ČSD, Ep. III	15003 130



Staubsilowagen, 2-achsrig

DR, Set, Ep. IV	01680 58
DR, Ep. IV	17700 58
DB, Ep. III	17731 70
DB, Ep. III	17762 70
DB, Ep. IV	17730 82
DB, Ep. IV	17732 82
DB, Ep. IV	17734 82
DB, Ep. IV	17761 82
DB AG, „VTG“, Set, Ep. V	01635 108
DB AG, Set, Ep. V	01706 109
DB AG, Ep. V	17766 109
DB AG, Ep. V	17701 109
DB AG, Ep. V	17765 109
ÖBB, Ep. IV	17733 149
FS, Ep. III	17763 164
SNCF, Set, Ep. IV	01681 165



Staubbehälterwagen, 4-achsrig

DR, Set, Ep. IV	01717 54
DR, Ep. IV	15488 54
ERMEWA, Ep. VI	15492 119
ERMEWA, Ep. VI	18251 119
NACCO, Ep. VI	18252 119
ČD, Ep. VI	15494 142
ÖBB, Ep. IV	18250 150
VTG, Ep. VI	15491 152
SBB, Ep. VI	15489 163
SNCF, Ep. V	15486 167
SNCB, Set, Ep. IV	01715 169

Bezeichnung	Seite
	
Schiebewandwagen	
VR, „Jit-Trans“, Ep. VI	15835 120
TWA, Ep. VI	15836 120
ČD Cargo, Ep. VI	15804 142
ZSSK Cargo, Ep. VI	15806 144
MAV, Ep. VI	15803 156
SBB, Ep. V	15802 161
SBB, Ep. VI	15807 163
Railion NL, Ep. VI	15808 171
SJ, Ep. IV	15805 172



Schiebeplanenwagen

AAE, „ENVILOC“, Ep. VI	15746 120
EuroLuxCargo, Ep. V/VI	15747 168



Autotransportwagen

DR, Set, Ep. IV	01636 48
DR, Ep. IV	15050 48
DB, Set, Ep. IV	01669 81
DB AG, Set, Ep. V	01704 95
DB AG, Set, Ep. V	01639 102
DB AG, Ep. V	15051 102
DB, Set, Ep. IV	01638 103
DB AG, Set, Ep. V	01640 103
ČD, Set, Ep. V	01641 140
ČD, Set, Ep. VI	01670 140
ZSSK, Set, Ep. V	01668 144
ÖBB, Set, Ep. IV	01702 149



Sonst. Güterwagen, 2-achsrig

K.P.E.V., Kalkkübel, Ep. I	14724 17
Bad.St.B, Säuret., Ep. I	14448 18
DRG, Säuretopf, Ep. II	14446 24
DR, Klappdeckel, Ep. III	14712 34
DR, Behälterwg., Ep. III	14911 34
DR, Säuretopf, Ep. IV	14447 51
DR, Werkstattwg. Ep. IV	13295 53
MAV, Weinfasswg. Ep. III	14437 153

Art.-Nr.	Seite	Art.-Nr.	Seite	Art.-Nr.	Seite	Art.-Nr.	Seite	Art.-Nr.	Seite
01207	188	01669	81	02096	39	02693	40	04964	116
01208	188	01670	140	02097	60	02709	174	04990	41
01209	189	01671	50	02101	18	02715	111	04991	116
01210	189	01673	22	02130	38	02741	75	07130	229
01211	189	01674	121	02133	74	02780	40	07160	229
01212	189	01675	35	02135	25	02791	86	07161	229
01353	90	01677	104	02145	25	02792	86	07170	229
01424	177	01678	105	02146	39	02850	29	07708	185
01425	181	01679	117	02160	26	02854	21	07723	185
01426	182	01680	58	02165	16	02881	87	07745	185
01431	178	01681	165	02166	19	02882	87	07750	185
01432	178	01682	16	02178	74	02885	111	07910	227
01434	179	01683	32	02179	26	03010	27	07911	227
01437	180	01684	33	02180	126	03011	39	07920	227
01438	180	01686	101	02181	19	04510	111	07950	204
01595	64	01688	158	02191	19	04511	112	07960	230
01596	146	01692	77	02285	146	04535	153	08122	223
01611	91	01693	65	02287	26	04536	112	08131	222
01612	92	01697	159	02288	168	04537	168	08132	223
01614	62	01698	44	02289	111	04588	87	08211	223
01617	21	01699	93	02295	74	04589	40	08330	215
01623	67	01702	149	02299	126	04590	113	08331	199
01625	155	01704	95	02314	88	04598	173	08401	223
01626	105	01705	52	02315	88	04611	127	08410	223
01627	37	01706	109	02337	41	04614	131	08414	226
01628	129	01710	73	02375	41	04615	127	08415	226
01630	85	01711	33	02379	88	04616	110	08419	227
01631	51	01712	50	02390	89	04621	127	08430	227
01635	108	01715	169	02391	89	04627	131	08608	183
01636	48	01716	140	02394	61	04628	145	08609	183
01638	103	01717	54	02395	89	04629	113	08632	183
01639	102	01718	57	02397	76	04635	127	08633	183
01640	103	01719	17	02398	114	04637	60	08634	183
01641	140	01833	175	02399	114	04801	75	08637	183
01642	37	01834	176	02450	40	04906	170	08690	183
01643	49	01835	176	02451	76	04907	161	08691	183
01644	73	01836	176	02452	146	04908	155	08692	183
01645	129	01837	176	02453	20	04909	90	08712	185
01646	122	02004	25	02454	28	04910	115	08713	185
01651	63	02005	38	02455	76	04911	115	08714	185
01652	72	02020	26	02457	61	04912	115	08737	183
01657	97	02021	74	02478	114	04915	115	08738	183
01658	42	02022	16	02484	114	04934	112	08739	183
01659	136	02023	18	02486	124	04935	112	08740	183
01660	43	02024	126	02500	75	04937	124	08741	183
01661	43	02025	38	02501	60	04940	87	08795	183
01662	44	02026	121	02503	75	04952	150	08796	183
01664	72	02051	25	02505	160	04953	124	08797	183
01666	162	02094	19	02582	27	04956	152	08798	183
01668	144	02095	121	02691	28	04962	136	08814	230

Art.-Nr.	Seite	Art.-Nr.	Seite	Art.-Nr.	Seite	Art.-Nr.	Seite	Art.-Nr.	Seite
08815	230	08972	227	13537	169	14109	171	14981	35
08818	228	08973	227	13538	164	14110	68	14982	130
08819	228	08974	227	13539	160	14117	174	14995	118
08820	228	08976	199	13541	149	14126	24	14996	81
08823	225	08976	227	13550	151	14127	159	14998	172
08824	225	08977	227	13551	163	14148	174	14999	118
08827	225	09548	230	13552	164	14269	174	15000	57
08828	225	09549	230	13553	125	14276	129	15002	71
08840	225	09571	231	13554	169	14277	121	15003	130
08841	225	09588	231	13555	151	14278	148	15050	48
08842	225	09601	231	13556	160	14282	23	15051	102
08843	225	09602	231	13558	149	14283	34	15115	35
08845	225	09603	231	13564	100	14284	18	15170	84
08846	225	09617	231	13565	98	14285	18	15171	165
08847	225	13001	29	13571	100	14437	153	15246	53
08848	225	13004	147	13574	78	14446	24	15247	105
08849	225	13005	20	13576	100	14447	51	15248	152
08854	229	13008	147	13581	101	14448	18	15250	133
08855	229	13009	128	13582	116	14479	81	15255	160
08856	229	13010	29	13584	78	14571	51	15256	154
08858	229	13017	147	13586	98	14574	52	15257	157
08869	229	13018	128	13587	62	14575	152	15258	165
08870	228	13149	16	13592	155	14576	68	15259	120
08871	228	13208	20	13593	46	14577	141	15260	144
08872	225	13228	173	13609	174	14578	144	15261	167
08874	228	13239	173	13625	174	14579	163	15262	156
08875	228	13295	53	13626	174	14585	84	15280	125
08876	228	13301	28	13697	77	14586	68	15281	106
08877	228	13315	77	13759	174	14587	52	15283	53
08878	228	13411	20	13779	91	14588	106	15298	141
08879	228	13412	29	13780	92	14589	117	15300	156
08880	228	13417	147	13800	96	14591	161	15350	53
08881	228	13423	20	13802	96	14628	17	15351	107
08882	228	13426	49	13803	96	14632	18	15352	107
08883	228	13455	17	13807	162	14649	174	15353	156
08884	228	13456	147	13827	22	14658	24	15354	119
08885	230	13475	148	13830	67	14690	55	15370	53
08886	230	13476	65	13850	67	14691	85	15371	106
08887	230	13518	66	13851	67	14693	141	15431	56
08888	230	13519	66	13856	80	14694	55	15432	167
08890	228	13522	94	13857	80	14695	133	15433	166
08894	228	13523	94	13863	80	14712	34	15467	157
08912	211	13524	94	13864	96	14724	17	15469	118
08913	211	13525	94	13873	46	14911	34	15471	141
08914	192	13526	77	13879	46	14922	129	15473	118
08931	227	13528	99	13887	30	14923	70	15474	167
08940	227	13530	79	13888	42	14924	82	15475	157
08960	227	13532	163	13889	46	14971	117	15476	166
08961	227	13535	151	13891	22	14972	117	15477	166
08970	227	13536	124	13892	128	14980	24	15478	170

Art.-Nr.	Seite	Art.-Nr.	Seite	Art.-Nr.	Seite	Art.-Nr.	Seite	Art.-Nr.	Seite
15479	164	16582	99	16922	64	17501	122	66020	190
15480	142	16590	78	16923	22	17502	129	66021	190
15486	167	16600	38	16940	30	17700	58	66022	190
15488	54	16601	93	16960	31	17701	109	66023	190
15489	163	16620	93	16970	31	17730	82	66024	190
15491	152	16621	42	16975	64	17731	70	66025	190
15492	119	16640	132	17001	24	17732	82	66050	193
15494	142	16641	154	17002	68	17733	149	66051	193
15568	83	16642	123	17003	121	17734	82	66120	192
15569	107	16643	132	17004	148	17761	82	66204	192
15571	135	16645	137	17132	35	17762	70	66588	192
15581	56	16646	137	17133	130	17763	164	66821	192
15587	160	16647	132	17134	70	17765	109	66824	192
15610	83	16650	47	17135	170	17766	109	66825	192
15650	104	16651	131	17136	169	18001	108	66835	192
15652	120	16652	47	17137	130	18002	150	66836	192
15746	120	16653	134	17150	69	18003	108	66837	192
15747	168	16656	135	17151	133	18004	150	66838	192
15802	161	16657	137	17152	154	18030	108	66844	192
15803	156	16658	143	17153	55	18100	170	83001	212
15804	142	16659	143	17154	102	18101	56	83003	212
15805	172	16660	47	17155	69	18102	56	83006	212
15806	144	16661	47	17156	69	18105	156	83007	212
15807	163	16662	125	17158	103	18107	107	83008	212
15808	171	16663	137	17159	135	18108	152	83009	212
15835	120	16664	137	17160	123	18109	125	83011	212
15836	120	16665	154	17162	84	18110	144	83012	212
16001	65	16667	134	17163	103	18150	161	83016	212
16100	98	16668	135	17164	55	18151	83	83025	212
16301	31	16695	138	17242	49	18152	83	83034	212
16341	31	16696	47	17243	84	18250	150	83036	212
16500	79	16697	131	17244	123	18251	119	83100	204
16501	98	16698	143	17245	69	18252	119	83101	204
16502	101	16700	145	17247	165	19001	184	83102	204
16503	79	16701	132	17248	168	19002	184	83103	204
16504	97	16703	145	17249	168	19003	184	83104	204
16505	100	16704	143	17250	153	19004	184	83105	204
16506	80	16705	139	17251	164	19005	184	83106	205
16507	80	16721	153	17252	157	19006	184	83107	205
16509	158	16722	123	17253	142	19007	184	83109	205
16520	138	16724	95	17300	148	19008	184	83110	205
16530	138	16725	134	17301	130	19009	184	83111	205
16531	151	16726	155	17302	23	19010	184	83112	205
16532	138	16727	125	17303	23	19020	184	83113	205
16533	98	16728	139	17304	71	19021	184	83114	205
16534	136	16729	143	17305	172	19022	184	83115	205
16535	101	16730	136	17400	171	19023	184	83116	205
16551	78	16750	46	17401	57	66012	193	83120	204
16580	79	16900	30	17402	170	66014	193	83125	206
16581	66	16920	30	17500	69	66017	193	83132	204

Art.-Nr.	Seite	Art.-Nr.	Seite	Art.-Nr.	Seite	Art.-Nr.	Seite	Art.-Nr.	Seite
83134 206	83442 204	83760 197	86326 219	95832 24
83136 206	83495 213	83761 197	86331 218	95833 37
83139 204	83500 212	83801 199	86332 218	95834 122
83143 211	83502 212	83802 199	86341 218	95835 23
83149 211	83517 215	83816 197	86342 218	95836 37
83150 211	83531 215	83817 197	86351 217	95837 171
83151 211	83532 215	83820 197	86352 217	95838 24
83154 211	83533 215	83821 197	86353 217	95839 71
83155 211	83534 215	83861 197	86354 217	95840 81
83156 211	83700 199	83862 197	86355 217	95841 171
83158 211	83701 196	83863 197	86356 217	95842 159
83159 211	83702 196	83864 197	86358 217	95843 165
83161 210	83703 196	83950 199	86360 217	95844 168
83170 210	83704 196	83951 199	86361 218	95845 172
83201 211	83705 196	83952 199	86362 218	95846 71
83210 210	83706 196	83953 199	86365 218	95847 57
83230 209	83707 196	83954 199	86366 218	96112 27
83300 210	83709 196	83955 199	86369 219	96114 110
83321 208	83710 196	83960 199	86370 219	96151 39
83322 208	83711 199	83961 199	86371 219	96154 113
83326 213	83712 196	83963 199	86372 219	96155 113
83327 213	83713 196	85500 213	86374 219	96156 27
83331 208	83714 196	85501 213	86376 219	210190 225
83332 208	83715 196	85502 212	86381 218	396942 199
83341 208	83716 196	85506 212	86382 218	396943 199
83342 208	83717 196	86101 212	86391 218	501067 41
83361 208	83718 196	86102 212	86392 218	501137 185
83362 208	83719 196	86112 215	86401 219	501273 36
83380 209	83720 196	86301 217	86406 219	501279 99
83382 209	83721 198	86302 217	86407 219	501285 23
83391 210	83722 198	86303 217	86411 219	501286 59
83410 212	83723 198	86304 217	86412 219	501287 45
83411 212	83724 198	86305 217	86413 221	501323 110
83416 213	83725 198	86306 217	86421 219	501324 58
83417 213	83726 198	86308 217	86422 219	501349 99
83420 212	83727 198	86310 217	92653 26	501350 116
83421 212	83728 198	86311 218	92654 153	501351 60
83426 213	83729 198	86312 218	95211 130	501357 42
83427 213	83730 198	86315 218	95212 122	501409 45
83430 212	83731 198	86316 218	95213 148	501410 45
83431 212	83732 198	86319 219	95214 133	501411 45
83436 213	83740 199	86320 219	95215 36		
83437 213	83741 199	86321 219	95216 157		
83440 212	83758 199	86322 219	95291 36		
83441 204	83759 199	86324 219	95830 71		

Impressum:

Herausgeber:

TLUG Modellbahnen GmbH
 Promenade 1, 01805 Sebnitz
 info@tlug.com, www.tlug.com

Gestaltung, Text und Druckvertrieb:
 TLUG Modellbahnen GmbH
 Werbeabteilung

Titelfoto: Diesellokomotive V100.10
 der DR, Sp. II
 ZfM-Nr. 9213513
 Diesellokomotive BR 110
 der DR, Sp. IV
 ZfM-Nr. 94938
 TLUG Werbeabteilung

Fotos:

Kamerablick: Sebnitz-Rennschiff;
 Ulrich Grauch, Neustadt/Sebnitz;
 Weitzschke TLUG, Sebnitz; Weitere fotos
 siehe Namensangaben an den Abbildungen.

Druck und Weiterverarbeitung:
 Neue Druckhaus Dresden GmbH
 Säbeldamm Str. 30, 01377 Dresden

Alle Rechte vorbehalten. Sonderausgaben und spätere Auflagen, Nachdrucke und ohne schriftliche Genehmigung vorbehalten. Text, Fotografien und Abbildungen eines Lesers für gewerbliche Zwecke oder sonstiger kommerzieller Zwecke ist ohne Erlaubnis, selbst auszugsweise, Kopieren oder Verbreiten von Auszügen der Texte "TLUG" strafbar. Die "TLUG" Redaktionen werden ausdrücklich über den Nachdruck informiert.

*Photografien Unentgeltlich anfertigen. Anfertigung für Lesernutzen.

Gedruckt in Deutschland, 2015



www.tlug.com

Ausblick

2016/2017



TILLIG Modellbahnen GmbH
Promenade 1, 01855 Sebnitz
Tel.: +49 (0)33671 903-0
E-Mail: info@tillig.com
www.tillig.com
www.facebook.com/tilligbahn

Ihr Fachhändler

